



Chipsmall Limited consists of a professional team with an average of over 10 year of expertise in the distribution of electronic components. Based in Hongkong, we have already established firm and mutual-benefit business relationships with customers from,Europe,America and south Asia,supplying obsolete and hard-to-find components to meet their specific needs.

With the principle of "Quality Parts,Customers Priority,Honest Operation,and Considerate Service",our business mainly focus on the distribution of electronic components. Line cards we deal with include Microchip,ALPS,ROHM,Xilinx,Pulse,ON,Everlight and Freescale. Main products comprise IC,Modules,Potentiometer,IC Socket,Relay,Connector.Our parts cover such applications as commercial,industrial, and automotives areas.

We are looking forward to setting up business relationship with you and hope to provide you with the best service and solution. Let us make a better world for our industry!



Contact us

Tel: +86-755-8981 8866 Fax: +86-755-8427 6832

Email & Skype: info@chipsmall.com Web: www.chipsmall.com

Address: A1208, Overseas Decoration Building, #122 Zhenhua RD., Futian, Shenzhen, China



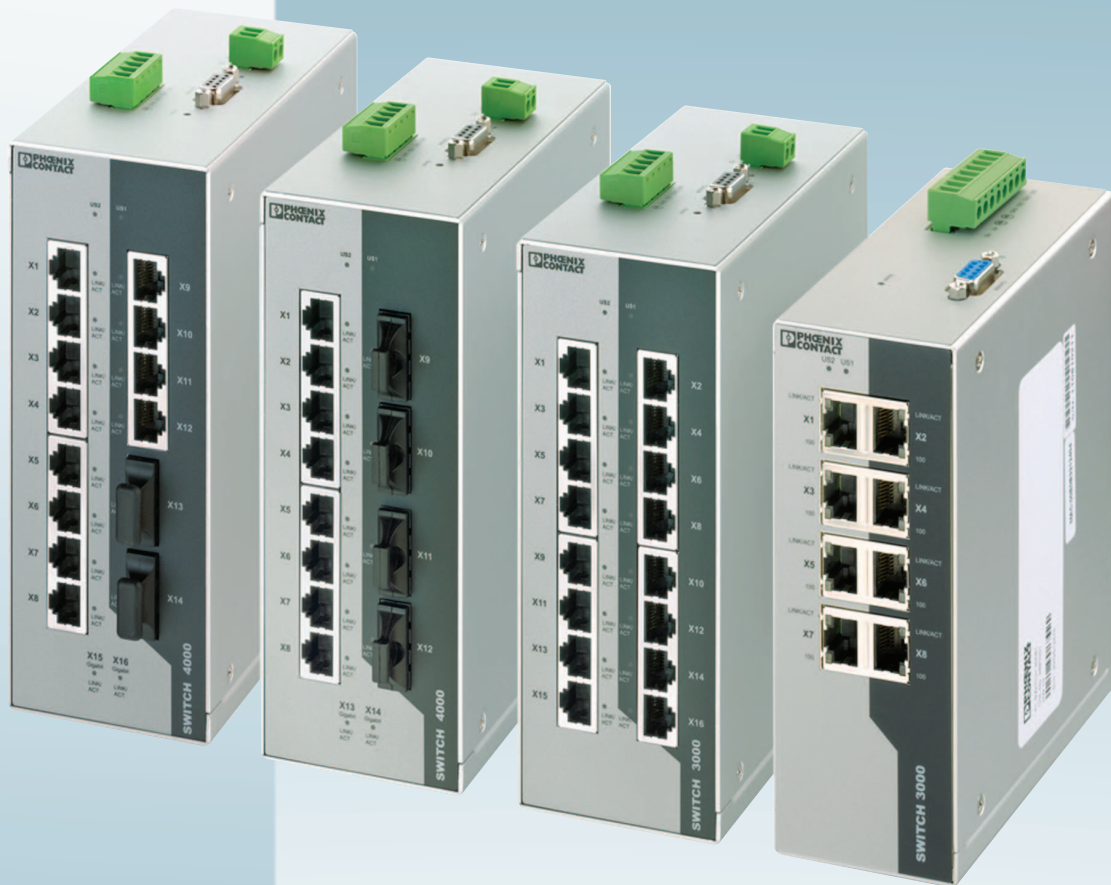

User manual

UM EN FL SWITCH 30..., 40... and 48...

Managed industrial switch

User manual

Managed industrial switch

2016-09-12

Designation: UM EN FL SWITCH 30..., 40... and 48...

Revision: L

This user manual is valid for:

Designation	Version	Order No.
FL SWITCH 3005		2891030
FL SWITCH 3008		2891031
FL SWITCH 3005T		2891032
FL SWITCH 3008T		2891035
FL SWITCH 3004T-FX		2891033
FL SWITCH 3004T-FX ST		2891034
FL SWITCH 3006T-2FX		2891036
FL SWITCH 3006T-2FX SM		2891060
FL SWITCH 3006T-2FX ST		2891037
FL SWITCH 3012E-2FX		2891120
FL SWITCH 3012E-2FX SM		2891119
FL SWITCH 3016		2891058
FL SWITCH 3016T		2891059
FL SWITCH 4008T-2GT-4FX SM		2891061

Designation	Version	Order No.
FL SWITCH 4008T-2SFP		2891062
FL SWITCH 4012T-2GT-2FX		2891063
FL SWITCH 3012E-2SFX		2891067
FL SWITCH 3016E		2891066
FL SWITCH 4824E-4GC		2891072
FL SWITCH 4808E-16FX LC-4GC		2891073
FL SWITCH 4808E-16FX SM LC-4GC		2891074
FL SWITCH 4808E-16FX-4GC		2891079
FL SWITCH 4808E-16FX SM-4GC		2891080
FL SWITCH 4012T-2GT-2FX ST		2891161
FL SWITCH 4008T-2GT-3FX SM		2891160
FL SWITCH 4808E-16FX ST-4GC		2891085
FL SWITCH 4808E-16FX SM ST-4GC		2891086
FL SWITCH 4800E-24FX-4GC		2891102
FL SWITCH 4800E-24FX SM-4GC		2891104

Please observe the following notes

User group of this manual

The use of products described in this manual is oriented exclusively to:

- Qualified electricians or persons instructed by them, who are familiar with applicable standards and other regulations regarding electrical engineering and, in particular, the relevant safety concepts.
- Qualified application programmers and software engineers, who are familiar with the safety concepts of automation technology and applicable standards.

Explanation of symbols used and signal words



This is the safety alert symbol. It is used to alert you to potential personal injury hazards. Obey all safety measures that follow this symbol to avoid possible injury or death.

There are three different categories of personal injury that are indicated with a signal word.

DANGER This indicates a hazardous situation which, if not avoided, will result in death or serious injury.

WARNING This indicates a hazardous situation which, if not avoided, could result in death or serious injury.

CAUTION This indicates a hazardous situation which, if not avoided, could result in minor or moderate injury.



This symbol together with the signal word **NOTE** and the accompanying text alert the reader to a situation which may cause damage or malfunction to the device, hardware/software, or surrounding property.



This symbol and the accompanying text provide the reader with additional information or refer to detailed sources of information.

How to contact us

Internet

Up-to-date information on Phoenix Contact products and our Terms and Conditions can be found on the Internet at:

phoenixcontact.com

Make sure you always use the latest documentation.

It can be downloaded at:

phoenixcontact.net/products

Subsidiaries

If there are any problems that cannot be solved using the documentation, please contact your Phoenix Contact subsidiary.

Subsidiary contact information is available at phoenixcontact.com.

Published by

PHOENIX CONTACT GmbH & Co. KG

Flachsmarktstraße 8

32825 Blomberg

GERMANY

Should you have any suggestions or recommendations for improvement of the contents and layout of our manuals, please send your comments to:

tecdoc@phoenixcontact.com

Please observe the following notes

General terms and conditions of use for technical documentation

Phoenix Contact reserves the right to alter, correct, and/or improve the technical documentation and the products described in the technical documentation at its own discretion and without giving prior notice, insofar as this is reasonable for the user. The same applies to any technical changes that serve the purpose of technical progress.

The receipt of technical documentation (in particular user documentation) does not constitute any further duty on the part of Phoenix Contact to furnish information on modifications to products and/or technical documentation. You are responsible to verify the suitability and intended use of the products in your specific application, in particular with regard to observing the applicable standards and regulations. All information made available in the technical data is supplied without any accompanying guarantee, whether expressly mentioned, implied or tacitly assumed.

In general, the provisions of the current standard Terms and Conditions of Phoenix Contact apply exclusively, in particular as concerns any warranty liability.

This manual, including all illustrations contained herein, is copyright protected. Any changes to the contents or the publication of extracts of this document is prohibited.

Phoenix Contact reserves the right to register its own intellectual property rights for the product identifications of Phoenix Contact products that are used here. Registration of such intellectual property rights by third parties is prohibited.

Other product identifications may be afforded legal protection, even where they may not be indicated as such.

Table of contents

1	Overview.....	5
1.1	Models.....	6
1.2	Structure.....	8
1.2.1	FL SWITCH 3006T-2FX	8
1.2.2	16-port FL SWITCH 30... switches	9
1.2.3	14- and 16-port FL SWITCH 40... switches	11
1.2.4	FL SWITCH 4824E-4GC switch	13
1.2.5	FL SWITCH 4808E-16FX...4GC switch	14
1.3	Installation notes	15
2	Installation	17
2.1	Mounting	17
2.1.1	FL SWITCH 30... and FL SWITCH 40...	17
2.1.2	FL SWITCH 48...E...	18
2.2	Removal	20
2.3	Connections	20
2.3.1	Power (FL SWITCH 30... and FL SWITCH 40...)	21
2.3.2	Power (FL SWITCH 48...E...)	22
2.3.3	Alarm contacts	23
2.3.4	RS-232 (V.24) interface	23
2.3.5	Use of SFP slots (FL SWITCH 40... SFP and FL SWITCH 48...E...) ..	24
3	Initial setup.....	27
3.1	Web-based management	27
3.2	Simple Network Management Protocol (SNMP).....	28
3.2.1	Private MIBs	30
3.3	Management via RS-232 (V.24)	30
3.3.1	Login	30
3.4	Telnet interface functions	33
3.5	IP addressing.....	34
3.5.1	Valid IP parameters	34
3.5.2	Assigning IP addresses	34
3.5.3	Subnet masks	36
3.5.4	Application	37
3.5.5	Factory default settings	37
3.5.6	Assigning IP parameters	38
3.5.7	Log in using web-based management	41
3.5.8	Modifying existing IP parameters	42
3.6	Device information.....	45
3.7	System identification	46
3.8	Login session	47
3.9	Log out	47

3.10	Software update	48
3.10.1	Software update	48
3.11	SNTP configuration	49
3.11.1	Configuring SNTP	50
3.12	Changing the user password	51
4	User accounts and web management.....	53
4.1	Web access modes	53
4.1.1	Login	53
4.1.2	Login and user accounts	54
4.2	User account management	57
4.3	Configuration management	59
4.3.1	Saving the configuration	59
4.3.2	Configuration file transfer	60
5	Switch station functions	63
5.1	Services.....	63
5.2	Port configuration	64
5.2.1	Port configuration table	64
5.2.2	Individual port configuration	65
5.3	Management interfaces	66
5.3.1	Web server protocol	66
5.3.2	Activating SNMP	68
5.4	Security	70
5.4.1	Port security and IEEE 802.1x	70
5.4.2	RADIUS authentication (IEEE 802.1x)	71
5.4.3	802.1x configuration table	73
5.4.4	Configuring the RADIUS server	73
5.4.5	MAC-based security overview	75
5.4.6	MAC-based security per port	75
5.4.7	MAC-based security global discard	77
5.5	Diagnostics.....	78
5.5.1	Trap configuration	78
5.5.2	Querying port states	79
5.5.3	Using port statistics	80
5.5.4	Configuring port mirroring	81
5.5.5	Display	83
5.5.6	Configuring alarm contacts	84
5.5.7	Utilization	85
5.5.8	Event table	86
5.5.9	Displaying the MAC address table	87
5.5.10	Link layer discovery protocol	87
5.5.11	LLDP topology	90

5.6	Redundancy	92
5.6.1	Spanning tree general	93
5.6.2	Configuring RSTP	94
5.6.3	Spanning tree port table	95
5.6.4	Spanning tree port configuration table	96
5.6.5	STP port configuration	97
5.6.6	MST	99
5.6.7	MST Global Config	100
5.6.8	MST Config	101
5.6.9	MST Port Config	102
5.6.10	Extended ring redundancy	103
5.6.11	Path control	117
5.7	Quality of service	119
5.7.1	Configuring quality of service	119
5.7.2	Priority mapping	122
5.7.3	Differentiated services	123
5.7.4	Flow control	124
5.7.5	Storm control	125
5.7.6	Traffic shaping	126
5.8	Multicast control	127
5.8.1	Procedure for creating a multicast group	127
5.8.2	General multicast configuration	128
5.8.3	Static multicast groups	129
5.8.4	Dynamic multicast groups	132
5.8.5	“General Multicast Configuration” page	133
5.8.6	Current multicast groups	134
5.9	VLAN	135
5.9.1	VLAN ID management	137
5.9.2	General VLAN configuration	138
5.9.3	Port-based VLAN configuration	140
5.9.4	Current VLANs	141
5.9.5	Tagging-based VLANs: Static VLANs	141
5.9.6	Native VLAN configuration	145
5.9.7	Tagging-based VLANs: Dynamic GVRP configuration	147
5.9.8	VLAN and RSTP	147
5.10	Link aggregation	148
5.10.1	Configuring link aggregation	148
A	Technical appendix – MIB objects	151
A 1	SNMP MIB objects	151
B	Technical appendix	161
B 1	Ordering data	161
B 2	Technical data	163

C	Appendices.....	171
	C 1	List of figures 171
	C 2	List of tables 175
	C 3	Index..... 177

1 Overview

The FL SWITCH 30..., 40... and 48... managed switches provide scalable power for application flexibility and ease of use. The switches are industrially hardened and offer a complete range of 10/100 connections and IEEE functions.

The FL SWITCH 30... range consists of managed switches with up to 16 ports that provide maximum redundancy, message filtering and security functions with both wide and normal industrial temperature ranges. The large IEEE function set meets application and IT department requirements, while retaining the ease of use needed by supporting plant floor personnel. Versions with 10/100 TX and TX/Fiber port combinations are available.

The FL SWITCH 30...E... range consists of managed switches with up to 16 ports that provide maximum redundancy, message filtering and security functions with wide industrial temperature ranges and IEC 61850 extended electrical noise immunity.

The FL SWITCH 40... range consists of managed switches with up to 16 ports and various combinations of RJ45 and fiber optic connections. FL SWITCH 40... switches contain the same large IEEE function set as the FL SWITCH 30... switches. The unique mix of 1000 Mbps, 10/100 Mbps and fiber optic ports allows a wide range of distributed and supervisory applications.

The FL SWITCH 48...E... range consists of rack-mounted managed switches with up to 28 ports with different port formats:

- Switches with 24 TX ports with 4 SFP/TX combo ports (“combo – means, “combination port”, where the user may use one of two interfaces – either a copper RJ45 or fiber media module.
- Switches with eight TX RJ45 ports with 16 FX-MM or SM fiber optic ports as well as the 4 SFP/TX combo ports that provide maximum redundancy, message filtering and security functions with wide, industrial temperature ranges and IEC 61850-3/IEEE 1613 substation hardened extended electrical noise immunity. The switch is compatible with DNP3 protocol-based devices.

The unique web simplification approach allows users to choose from extensive redundancy, message filtering and security functions, while reducing overall system complexity. It allows maintenance personnel complete access to read diagnostic information without login requirements.

Maximum network availability is ensured through redundant power supply, rapid spanning tree (RST) and extended ring protocols. Browser-based configuration pages make configuration simple. For further simplification, unused configuration pages can be hidden from less experienced personnel, such as those on the plant floor.

1.1 Models

The FL SWITCH 30... switch is available with five or eight ports and fiber optic ports in either SC or ST format. The FL SWITCH 40... provides 10, 14 or 16 ports and SC or LC (SFP) fiber optic ports. Each switch has two 1000 Mbps uplink ports. The FL SWITCH 48...E... provides 28 ports with different port formats, such as RJ45, LC and SFP.

The available models are:

Table 1-1 Models

	No. of RJ45 ports: 10/100	No. of RJ45 ports: 10/100/1000	No. of fiber optic ports	No. of GC ports ¹
FL SWITCH 3005	5	-	-	
FL SWITCH 3005T	5	-	-	
FL SWITCH 3008	8	-	-	
FL SWITCH 3008T	8	-	-	
FL SWITCH 3016	16	-	-	
FL SWITCH 3016T	16	-	-	
FL SWITCH 3004T-FX	4	-	1 (SC, Multimode, 100 Mbps)	
FL SWITCH 3004T-FX ST	4	-	1 (ST, Multimode, 100 Mbps)	
FL SWITCH 3006T-2FX	6	-	2 (SC, Multimode, 100 Mbps)	
FL SWITCH 3006T-2FX ST	6	-	2 (ST, Multimode, 100 Mbps)	
FL SWITCH 3006T-2FX SM	6	-	2 (SC, Single mode, 100 Mbps)	
FL SWITCH 3012E-2SFX	12	-	2 (SFP slots - LC, 100 Mbps)	
FL SWITCH 3012E-2FX	12	-	2 (SC, Multimode, 100 Mbps)	
FL SWITCH 3012E-2FX SM	12	-	2 (SC, Single mode, 100 Mbps)	
FL SWITCH 3016E	16	-	-	
FL SWITCH 4008T-2SFP ³	8	-	2 (SFP slots - LC, 1000 Mbps)	
FL SWITCH 4012T-2GT-2FX	12	2	2 (SC, Multimode, 100 Mbps)	
FL SWITCH 4012T-2GT-2FX ST	12	2	2 (ST, Multimode, 100 Mbps)	
FL SWITCH 4008T-2GT-3FX SM	8	2	3 (SC, Single mode, 100 Mbps)	
FL SWITCH 4008T-2GT-4FX SM	8	2	4 (SC, Single mode, 100 Mbps)	

Table 1-1 Models

	No. of RJ45 ports: 10/100	No. of RJ45 ports: 10/100/1000	No. of fiber optic ports	No. of GC ports ¹
FL SWITCH 4824E-4GC ³	24			4
FL SWITCH 4808E-16FX LC-4GC ³	8		16 (LC, Multimode, 100 Mbps)	4
FL SWITCH 4808E-16FX SM LC-4GC ³	8		16 (LC, Single mode, 100 Mbps)	4
FL SWITCH 4808E-16FX LC-4GC ³	8		16 (SC, Multimode, 100 Mbps)	4
FL SWITCH 4808E-16FX LC-4GC ³	8		16 (SC, Single mode, 100 Mbps)	4
FL SWITCH 4808E-16FX ST-4GC ³	8		16 (ST, Multimode, 100 Mbps)	4
FL SWITCH 4808E-16FX SM ST-4GC ³	8		16 (ST, Single mode, 100 Mbps)	4
FL SWITCH 4800E-24FX-4GC ³			24 (SC, Multimode, 100 Mbps)	4
FL SWITCH 4800E-24FX SM-4GC ³			24 (SC, Single mode, 100 Mbps)	4

¹ GC ports are combination ports that allow connection through either RJ45 or fiber optic connection. The RJ45 ports connect at 10/100/1000 Mbps and the fiber optic ports connect at 1000 Mbps via an SFP module. The RJ45 and fiber optic connection for a single port cannot be used at the same time.

³ SFP slots accept only 1000 Mbps modules

1.2 Structure

1.2.1 FL SWITCH 3006T-2FX

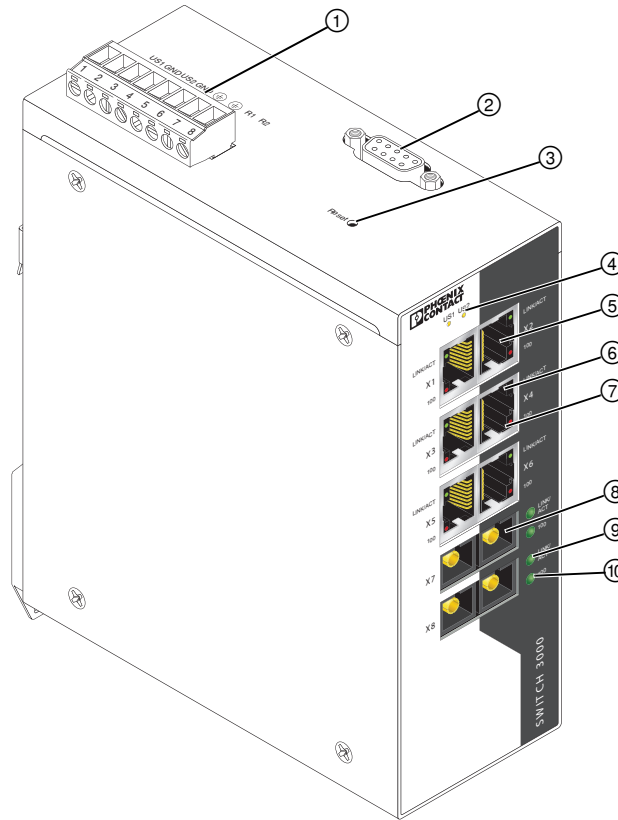

Figure 1-1 Structure of the FL SWITCH 3006T-2FX

Table 1-2 Structure of the FL SWITCH 3006T-2FX

1	Power supply/remote alarm connector	
2	RS-232 serial port (9-pos. D-SUB)	
3	Reset button	<p>Press and hold for less than 10 seconds to reboot with the saved configuration. The IP address is retained.</p> <p>Press and hold until all LEDs flash (approximately 30 seconds) to reboot using the factory defaults. The saved configuration and IP address will be lost.</p> <div style="border: 1px solid black; padding: 5px; margin-top: 10px;"> <p>i The reset button may be disabled for security purposes (see “Services” on page 63).</p> </div>
4	Power indicator LEDs (US1/US2)	<p>Green indicates voltage supply is within range.</p> <p>Off indicates a voltage supply is below 18 V.</p>

Table 1-2 Structure of the FL SWITCH 3006T-2FX (continued)

5	RJ45 ports	
6	RJ45 port LNK/ACT LED	Green indicates link is active. Off indicates link is not active. Flashing indicates data transfer.
7	RJ45 port 100 LED	Orange indicates 100 Mbps. Off indicates 10 Mbps.
8	Fiber optic port	
9	Fiber optic LNK/ACT LED	Green indicates link is active. Off indicates link is not active. Flashing indicates data transfer.
10	Fiber optic 100 LED	Orange indicates 100 Mbps. Off indicates link is not active.

1.2.2 16-port FL SWITCH 30... switches

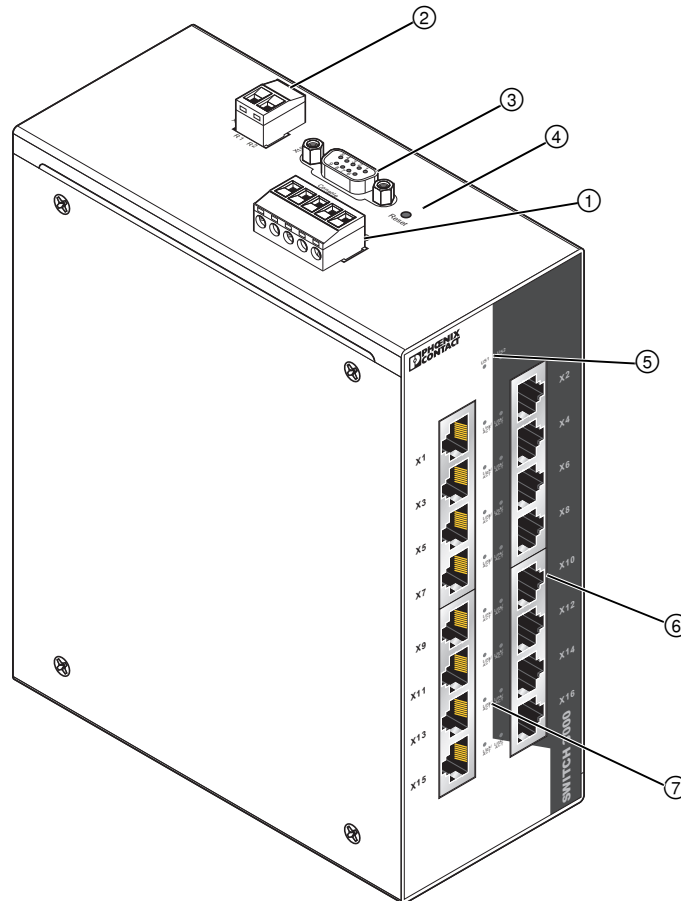



Figure 1-2 Structure of the FL SWITCH 3016

FL SWITCH 30..., 40... and 48...

Table 1-3 Structure of the FL SWITCH 3016

1	Power supply	
2	Remote alarm connector	
3	RS-232 serial port (9-pos. D-SUB)	
4	Reset button	<p>Press and hold for less than 10 seconds to reboot with the saved configuration. The IP address is retained. Press and hold until all LEDs flash (approximately 30 seconds) to reboot using the factory defaults. The saved configuration and IP address will be lost.</p> <div data-bbox="722 617 1200 716" style="border: 1px solid black; padding: 5px;"> The reset button may be disabled for security purposes (see "Services" on page 63).</div>
5	Power indicator LEDs (US1/US2)	<p>Green indicates voltage supply is within range. Off indicates a voltage supply is below 18 V.</p>
6	RJ45 ports	
7	RJ45 port LED (LNK/ACT)	<p>Green indicates link is active. Off indicates link is not active. Flashing indicates data transfer.</p>

1.2.3 14- and 16-port FL SWITCH 40... switches

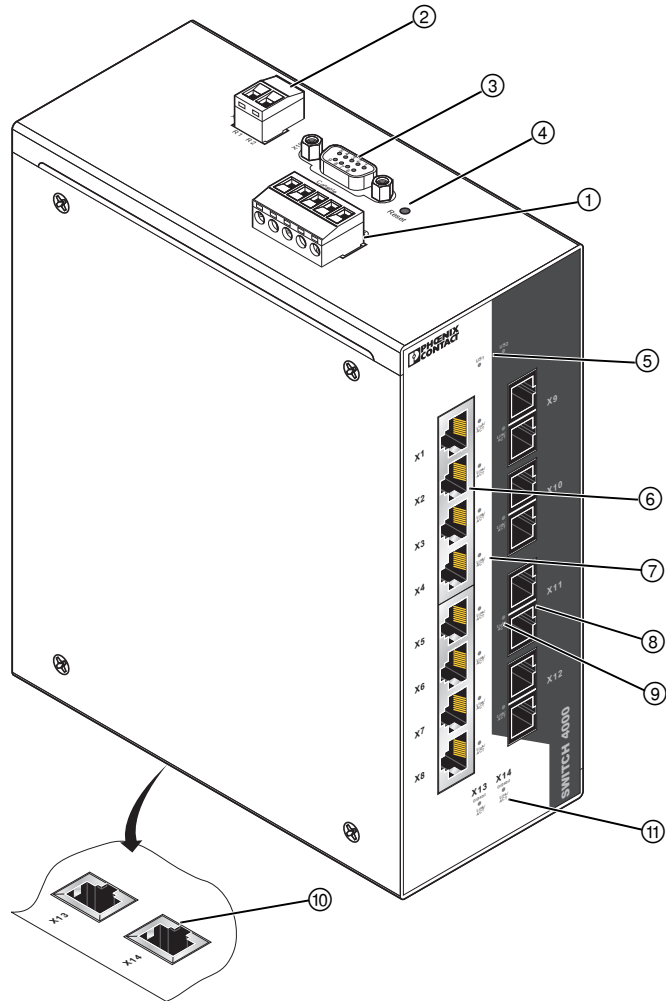



Figure 1-3 Structure of the FL SWITCH 4008T-2GT

FL SWITCH 30..., 40... and 48...

Table 1-4 Structure of the FL SWITCH 4008T-2GT

1	Power supply	
2	Remote alarm connector	
3	RS-232 serial port (9-pos. D-SUB)	
4	Reset button	<p>Press and hold for less than 10 seconds to reboot with the saved configuration. The IP address is retained. Press and hold until all LEDs flash (approximately 30 seconds) to reboot using the factory defaults. The saved configuration and IP address will be lost.</p> <div style="border: 1px solid black; padding: 5px; display: inline-block;">  <p>The reset button may be disabled for security purposes (see “Services” on page 63).</p> </div>
5	Power indicator LEDs (US1/US2)	<p>Green indicates voltage supply is within range. Off indicates a voltage supply is below 18 V.</p>
6	RJ45 ports	
7	RJ45 port LEDs (LNK/ACT)	<p>Green indicates link is active. Off indicates link is not active. Flashing indicates data transfer.</p>
8	Fiber optic ports	
9	Fiber optic LNK/ACT LED	<p>Green indicates link is active. Off indicates link is not active. Flashing indicates data transfer.</p>
10	RJ45 1000 Mbps ports	
11	RJ45 1000 Mbps port LEDs (LNK/ACT)	<p>Orange indicates 1000 Mbps. Off indicates link is not active.</p>

1.2.4 FL SWITCH 4824E-4GC switch

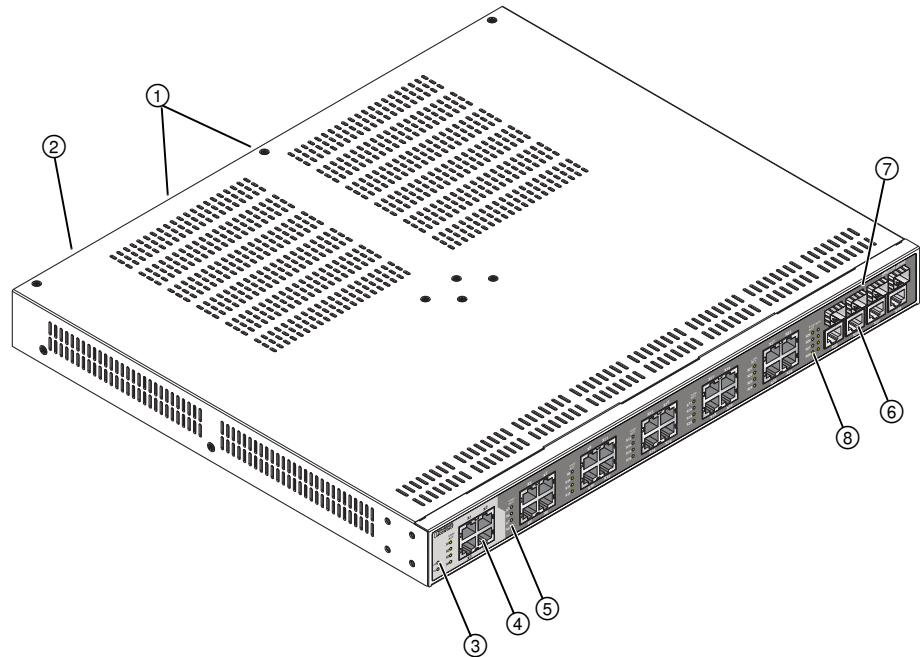

Figure 1-4 Structure of the FL SWITCH 4824E-4GC

Table 1-5 Structure of the FL SWITCH 4824E-4GC

1	Power supply slots	
2	RS-232 serial port (9-pos. D-SUB)	
3	Power indicator LEDs (US1/US2)	Green indicates voltage supply is within range. Off indicates a voltage supply is below 18 V.
4	RJ45 ports (10/100 Mbps)	
5	RJ45 port LEDs (LNK/ACT)	Green indicates link is active. Off indicates link is not active. Flashing indicates data transfer.
6	Gigabit combination ports - RJ45 connection	
7	Gigabit combination ports - Fiber optic connection (1000 Mbps)	
8	Gigabit combination port LEDs	Green indicates link is active. Off indicates link is not active. Flashing indicates data transfer.

1.2.5 FL SWITCH 4808E-16FX...4GC switch

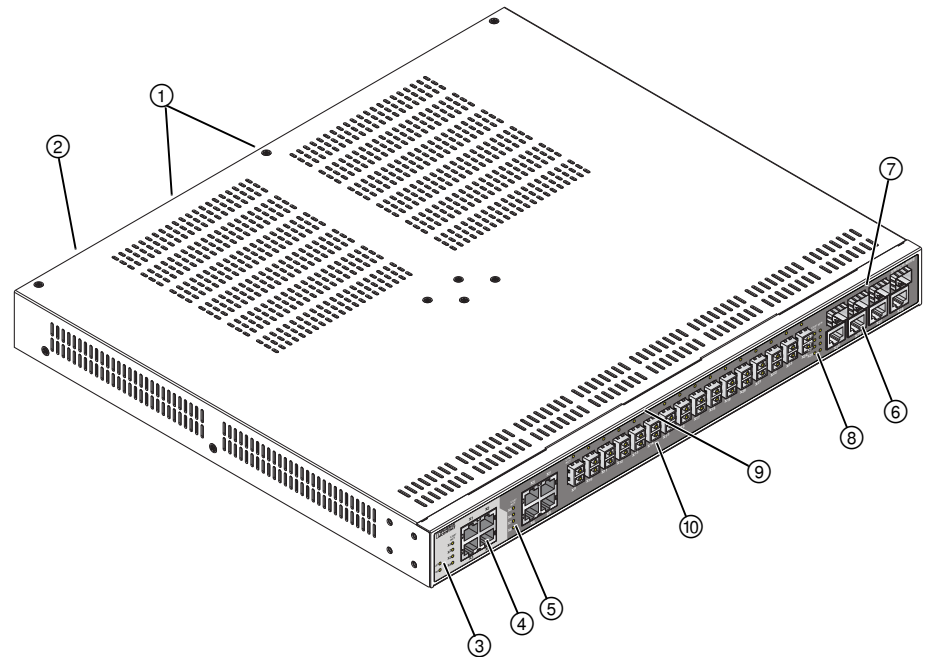

Figure 1-5 Structure of the FL SWITCH 4808E-16FX...4GC

Table 1-6 Structure of the FL SWITCH 4808E-16FX...4GC

1	Power supply slots	
2	RS-232 serial port (9-pos. D-SUB)	
3	Power indicator LEDs (US1/US2)	Green indicates voltage supply is within range. Off indicates a voltage supply is below 18 V.
4	RJ45 ports	
5	RJ45 port LEDs (LNK/ACT)	Green indicates link is active. Off indicates link is not active. Flashing indicates data transfer.
6	Gigabit combination ports - RJ45 connection	
7	Gigabit combination ports - Fiber optic connection	
8	Gigabit combination port LEDs	Green indicates link is active. Off indicates link is not active. Flashing indicates data transfer.
9	Fiber optic ports (100 Mbps)	
10	Fiber optic LNK/ACT LED	Green indicates link is active. Off indicates link is not active. Flashing indicates data transfer.

1.3 Installation notes

**WARNING:**

Do not look directly into the fiber optic ports when operational. The laser lightst can cause blindness or damage vision.

The user shall be responsible for ensuring the integrity of any protective conductor connections before carrying out any other actions. The protective earth connections should not be removed when the equipment is energized.

The user shall be responsible for checking equipment ratings, operating instructions, and installation instructions before commissioning or maintenance. It is the responsibility of the user to ensure that the equipment is installed, operated, and used for it's intended function in a manner specified by the manufacturer. Failure to do to this may impair safety protection mechanisms of the equipment.

The equipment conforms to pollution degree 2 when installed according to the normal position of use.

The FL SWITCH 4800E-P... power supplies contain factory-soldered (not user replaceable) fuses with the values: 400 V, 5 A, T (10 s).

2 Installation

2.1 Mounting

2.1.1 FL SWITCH 30... and FL SWITCH 40...

Mount the FL SWITCH 30... and FL SWITCH 40... on a clean DIN rail according to EN 50022. To avoid contact resistance, only use clean, corrosion-free DIN rails.

Before mounting the modules, an end clamp (E/NS 35N, Order No. 0800886) should be placed on the left-hand side next to the switch to stop the module from slipping on the DIN rail. After the switch is mounted, install an end clamp on the right-hand side of the switch.

1. Place the module onto the DIN rail from above (1). The upper holding keyway must be hooked onto the top edge of the DIN rail. Push the module from the front toward the mounting surface (2).

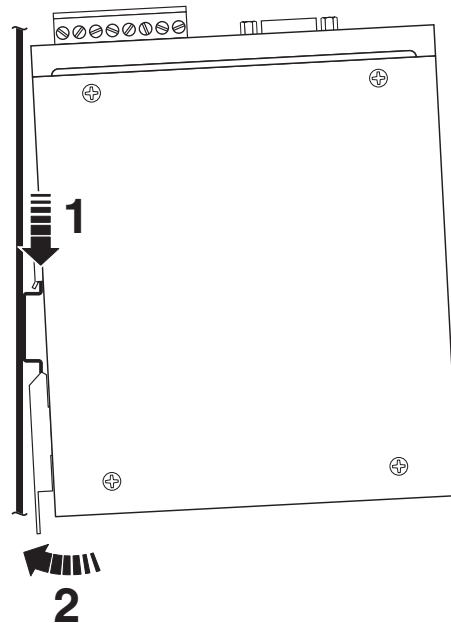

Figure 2-1 DIN rail installation

2. Once the module is snapped on properly, check that it is fixed securely on the DIN rail.
3. To prevent slipping along the DIN rail, install end clamps (E/NS 35N, Order No. 0800886) on each side of the module.

2.1.2 FL SWITCH 48...E...

The FL SWITCH 48...E... switch is for installation in a standard 19-inch rack. The optional FL RMB 4800E (Order No. 2891054) can be purchased separately for high-vibration and shock environments that require a more rugged installation.



It is recommended that 1U (rack unit) of space be kept free above each FL SWITCH 48...E... to allow additional air flow for heat dissipation. While not a requirement, the space will allow the switch to operate at a reduced temperature.



Because of tight spaces in most rack assemblies, connect the cord to the back of the switch before installing. See “Power (FL SWITCH 30... and FL SWITCH 40...)” on page 21 for additional information.

Standard mounting bracket installation

1. Attach the two mounting brackets (1) to the switch using the one M3 screw (2) and three M4 screws (3) provided.

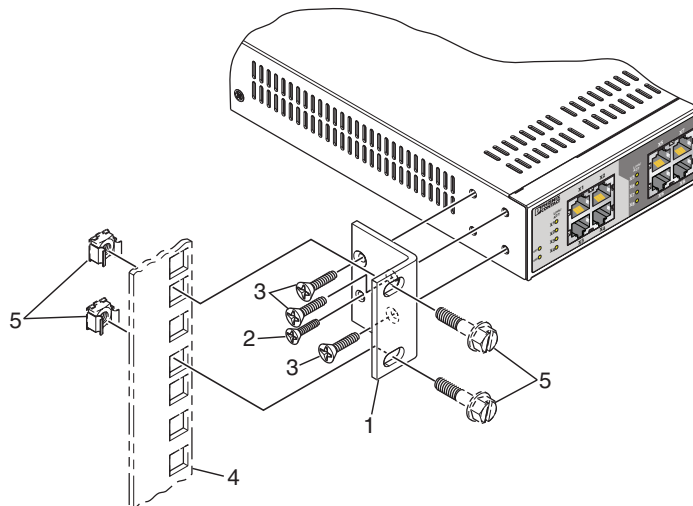

Figure 2-2 19-inch rack mounting with standard mounting brackets

2. Connect the user-supplied power cord into the rear of the switch.
3. Place the switch in the desired location on the rack (4). Use the rack hardware (5) to secure the switch in place on the rack.

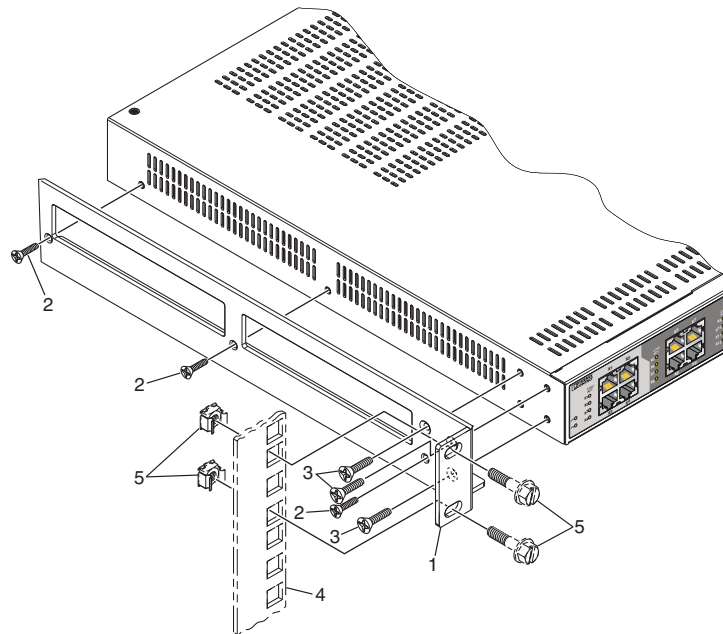
Optional FL RMB 4800E mounting bracket installation

Figure 2-3 19-inch rack mounting with optional FL RMB 4800E mounting brackets

1. Attach one mounting bracket (1) to the side of the switch using the three M3 screws (2) and three M4 screws (3) provided.
2. Repeat for the other side.
3. Place the switch in the desired location on the mounting rack (4). Use the mounting hardware (5) provided with the mounting rack to secure the switch.