



Chipsmall Limited consists of a professional team with an average of over 10 year of expertise in the distribution of electronic components. Based in Hongkong, we have already established firm and mutual-benefit business relationships with customers from,Europe,America and south Asia,supplying obsolete and hard-to-find components to meet their specific needs.

With the principle of "Quality Parts,Customers Priority,Honest Operation,and Considerate Service",our business mainly focus on the distribution of electronic components. Line cards we deal with include Microchip,ALPS,ROHM,Xilinx,Pulse,ON,Everlight and Freescale. Main products comprise IC,Modules,Potentiometer,IC Socket,Relay,Connector.Our parts cover such applications as commercial,industrial, and automotives areas.

We are looking forward to setting up business relationship with you and hope to provide you with the best service and solution. Let us make a better world for our industry!



## Contact us

Tel: +86-755-8981 8866 Fax: +86-755-8427 6832

Email & Skype: info@chipsmall.com Web: www.chipsmall.com

Address: A1208, Overseas Decoration Building, #122 Zhenhua RD., Futian, Shenzhen, China



# IL EIP BK DI8 DO4 2TX-PAC

Inline bus coupler for EtherNet/IP™,  
8 inputs 24 V DC, 4 outputs 24 V DC, 500 mA



Data sheet  
7537\_en\_01

© PHOENIX CONTACT 2018-04-04

## 1 Description

The bus coupler with integrated I/Os is intended for use within an EtherNet/IP™ network and represents the link to the Inline I/O system.

Up to 61 Inline devices can be connected to the bus coupler. The bus coupler supports a maximum of 8 PCP devices. A corresponding EDS file is available for integrating the Inline station into the programming system. This file can be downloaded via the product at [phoenixcontact.net/products](http://phoenixcontact.net/products).

### Features

- 8 digital inputs, 4 digital outputs onboard
- EtherNet/IP™, Version 1.2
- Web-based management
- 2 RJ45 connections
- Automatic detection of the transmission speed in the local bus (500 kbps or 2 Mbps)

### Ethernet and CIP features

- Type of device profile: 0C<sub>hex</sub> communication adapter
- Supported CIP connections in total: 128 (typically eight)
- Explicit signaling: max. number of connections: 128 (typically eight)
- I/O messages: max. number of connections: 128 (typically eight)
- Device configuration options: EDS, individual software
- MAC parameter configuration: Rate: 10 Mbps, 100 Mbps, automatic duplex: half, full, automatic



For additional information, please refer to the UM DE IL EIP BK DI8 DO4 2TX-PAC user manual.



This data sheet is only valid in association with the IL SYS INST UM E user manual.



Make sure you always use the latest documentation. It can be downloaded from the product at [phoenixcontact.net/products](http://phoenixcontact.net/products).

<b>2</b>	<b>Table of contents</b>	
1	Description .....	1
2	Table of contents .....	2
3	Ordering data .....	3
4	Technical data .....	4
5	Internal circuit diagram .....	9
6	Connecting Ethernet, the supply, actuators, and sensors.....	10
	6.1 Connecting Ethernet.....	10
	6.2 Connecting the supply, actuators, and sensors - terminal point assignment.....	10
7	Connection example.....	11
8	Local diagnostic and status indicators .....	12
9	Reset button .....	14
	9.1 Restarting the bus coupler .....	14
	9.2 Restoring the default settings.....	14
10	Startup.....	15
	10.1 Starting the firmware .....	15
	10.2 Sending BootP requests .....	15
11	Startup behavior of the bus coupler .....	15
	11.1 Startup diagrams for the bus coupler .....	16
12	EtherNet/IP™ object classes .....	17
	12.1 CIP class and instance services .....	17
	12.2 CIP object classes .....	17
13	Operating guidelines for the system .....	18
	13.1 “Repeat packet interval (RPI)” settings .....	18
	13.2 Maximum connections .....	18
14	WBM - Web-based management .....	18
15	Configuration of the PDU size for PCP.....	18

### 3 Ordering data

Description	Type	Order No.	Pcs./Pkt.
Inline, bus coupler, EtherNet/IP™, RJ45 socket, digital inputs: 8, 24 V DC, connection method: 3-wire, digital outputs: 4, 24 V DC, 500 mA, connection method: 3-wire, transmission speed in the local bus: 500 kbps / 2 Mbps, degree of protection: IP20, including Inline connectors and marking fields	IL EIP BK DI8 DO4 2TX-PAC	2897758	1
Accessories	Type	Order No.	Pcs./Pkt.
Quick mounting end clamp for NS 35/7,5 DIN rail or NS 35/15 DIN rail, with marking option, width: 9.5 mm, color: gray (Assembly)	CLIPFIX 35	3022218	50
End clamp, width: 9.5 mm, height: 35.3 mm, material: PA, length: 50.5 mm, Mounting on a DIN rail NS 32 or NS 35, color: gray (Assembly)	E/UK	1201442	50
Insert strip, Sheet, white, unlabeled, can be labeled with: Office printing systems: Laser printer, mounting type: insert, lettering field size: 62 x 46 mm (Marking)	ESL 62X46	0809502	5
Labeling field, width: 48.8 mm (Marking)	IB IL FIELD 8	2727515	10
Insert strip, Sheet, white, unlabeled, can be labeled with: Office printing systems: Laser printer, mounting type: insert, lettering field size: 62 x 10 mm (Marking)	ESL 62X10	0809492	1
Labeling field, width: 12.2 mm (Marking)	IB IL FIELD 2	2727501	10
RJ45 connector, shielded, with bend protection sleeve, 2 pieces, gray for straight cables, for assembly on site. For connections that are not crossed, it is recommended that you use the connector set with gray bend protection sleeve. (Connector/Adapter)	FL PLUG RJ45 GR/2	2744856	1
RJ45 connector, shielded, with bend protection sleeve, 2 pieces, green for crossed cables, for assembly on site. For connections that are crossed, it is recommended that the connector set with green bend protection sleeves is used. (Connector/Adapter)	FL PLUG RJ45 GN/2	2744571	1
CAT5-SF/UTP cable (J-02YS(ST)C HP 2 x 2 x 24 AWG), heavy-duty installation cable, 2 x 2 x 0.22 mm <sup>2</sup> , solid conductor, shielded, outer sheath: 7.8 mm diameter, inner sheath: 5.75 mm ± 0.15 mm diameter (Cable/conductor)	FL CAT5 HEAVY	2744814	1
CAT5-SF/UTP cable (J-LI02YS(ST)C H 2 x 2 x 26 AWG), light-duty, flexible installation cable 2 x 2 x 0.14 mm <sup>2</sup> , stranded, shielded, outer sheath: 5.75 mm ± 0.15 mm diameter (Cable/conductor)	FL CAT5 FLEX	2744830	1

Accessories	Type	Order No.	Pcs./Pkt.
Crimping pliers, for assembling the RJ45 plugs FL PLUG RJ45..., for assembly on site (Tools)	FL CRIMPTOOL	2744869	1
Connector set, for Inline bus coupler with I/Os mounted in rows (Connector/Adapter)	IL BKDIO-PLSET	2878599	1
IPAssign is an easy to use tool for setting the IP address of devices which rely on BOOTP. No installation or administrative rights are required to use IPAssign.	IPASSIGN	2701094	1

This product is free and only available from the "Downloads" tab.

Documentation	Type	Order No.	Pcs./Pkt.
User manual, English, Inline bus coupler for EtherNet/IP™ with eight digital inputs and four digital outputs	UM EN IL EIP BK D18 DO4-2TX-PAC	-	-
Quick start guide, English, Integration of the IL EIP BK D18 DO4 2TX-PAC bus coupler into a Modicon M340 controller	UM QS EN IL EIP BK - M340	-	-
User manual, English, Automation terminals of the Inline product range	IL SYS INST UM E	-	-
Application note, German/English, I/O modules at bus couplers	AH IL BK IO LIST	-	-

## 4 Technical data

### Dimensions (nominal sizes in mm)

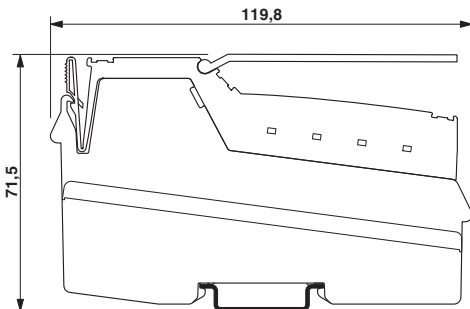

Width	80 mm
Height	119.8 mm
Depth	71.5 mm
Note on dimensions	Specifications with connectors

General data	
Color	green
Weight	320 g (with connectors)
Ambient temperature (operation)	-25 °C ... 60 °C
Ambient temperature (storage/transport)	-25 °C ... 85 °C
Permissible humidity (operation)	10 % ... 95 % (non-condensing)
Permissible humidity (storage/transport)	10 % ... 95 % (non-condensing)
Air pressure (operation)	70 kPa ... 106 kPa (up to 3000 m above sea level)
Air pressure (storage/transport)	70 kPa ... 106 kPa (up to 3000 m above sea level)
Degree of protection	IP20
Protection class	III, IEC 61140, EN 61140, VDE 0140-1

Connection data: Inline connector	
Connection method	Spring-cage connection
Conductor cross section solid / stranded	0.08 mm <sup>2</sup> ... 1.5 mm <sup>2</sup> / 0.08 mm <sup>2</sup> ... 1.5 mm <sup>2</sup>
Conductor cross section [AWG]	28 ... 16
Stripping length	8 mm

Connection data for UL approvals: Inline connector	
Connection method	Spring-cage connection
Conductor cross section solid / stranded	0.2 mm <sup>2</sup> ... 1.5 mm <sup>2</sup> / 0.2 mm <sup>2</sup> ... 1.5 mm <sup>2</sup>
Conductor cross section [AWG]	24 ... 16
Stripping length	8 mm

Interface: EtherNet/IP™	
Number	2
Connection method	RJ45 socket
Note on the connection method	Auto negotiation and autocrossing
Permissible conductor cross section	0.14 mm <sup>2</sup> ... 0.22 mm <sup>2</sup> (twisted pair)
Transmission speed	10/100 Mbps (half or full duplex (automatic detection))
Transmission physics	Ethernet in RJ45 twisted pair
Transmission length	max. 100 m

Interface: Inline local bus	
Connection method	Inline data jumper
Transmission speed	500 kbps / 2 Mbps (Automatic detection, no combined system)

System limits of the bus coupler	
Amount of process data	max. 512 Byte (per station)
Number of supported devices	max. 63 (per station)
Number of local bus devices that can be connected	max. 61 (on board I/Os are two devices)
Number of devices with parameter channel	max. 8



Observe the logic current consumption of each device when configuring an Inline station! It is specified in every terminal-specific data sheet. The current consumption can differ depending on the individual terminal. The permissible number of devices that can be connected therefore depends on the specific station structure.

**Bus coupler supply  $U_{BC}$ ; Communications power  $U_L$  (7.5 V) and the analog supply  $U_{ANA}$  (24 V) are generated from the bus coupler supply.**

Supply voltage	24 V DC (via Inline connector)
Supply voltage range	19.2 V DC ... 30 V DC (including all tolerances, including ripple)
Current draw	max. 0.98 A
Cable length	max. 30 m (Do not route cable through outdoor areas)

**Communications power  $U_L$** 

Supply voltage	7.5 V DC
Power supply unit	max. 0.8 A DC

**Supply of analog modules  $U_{ANA}$** 

Supply voltage	24 V DC
Supply voltage range	19.2 V DC ... 30 V DC (including all tolerances, including ripple)
Power supply unit	max. 0.5 A DC

**Main circuit supply  $U_M$** 

Supply voltage	24 V DC (via Inline connector)
Supply voltage range	19.2 V DC ... 30 V DC (including all tolerances, including ripple)
Power supply unit	max. 8 A DC (Sum of $U_M + U_S$ )
Current draw	max. 8 A DC
Cable length	max. 30 m (Do not route cable through outdoor areas)

**Segment circuit supply  $U_S$** 

Supply voltage	24 V DC (via Inline connector)
Supply voltage range	19.2 V DC ... 30 V DC (including all tolerances, including ripple)
Power supply unit	max. 8 A DC (Sum of $U_M + U_S$ )
Current draw	max. 8 A DC
Cable length	max. 30 m (Do not route cable through outdoor areas)

**Power consumption**

Power consumption	typ. 3 W (entire device)
-------------------	--------------------------

**Protection****NOTE: Electronics may be damaged when overloaded**

Provide external protection for the 24 V areas  $U_{BK}$ ,  $U_M$ , and  $U_S$ . If you are using an external fuse, the power supply unit must be able to supply four times the nominal current of the fuse. This ensures that it trips in the event of an error.

**Digital inputs**

Number of inputs	8
Connection method	Inline connector
Connection technology	3-wire
Input characteristic curve	IEC 61131-2 type 1
Nominal input voltage	24 V DC
Nominal input current	typ. 3 mA
Current flow	Limited to 3 mA, maximum
Input voltage range "0" signal	-30 V DC ... 5 V DC
Input voltage range "1" signal	15 V DC ... 30 V DC
Delay at signal change from 0 to 1	typ. 1.2 ms
Delay at signal change from 1 to 0	typ. 1.2 ms
Permissible conductor length to the sensor	100 m
Use of AC sensors	AC sensors in the voltage range $< U_{IN}$ are limited in application (according to the input design)
Reverse polarity protection	Suppressor diode

**Digital outputs**

Number of outputs	4
Connection method	Inline connector
Connection technology	3-wire
Nominal output voltage	24 V DC
Voltage difference with nominal current	$< 1$ V
Maximum output current per channel	500 mA
Maximum output current per device	2 A
Nominal load, ohmic	12 W
Nominal load, inductive	12 VA (1.2 H, 48 $\Omega$ )
Nominal load, lamp	12 W
Signal delay	typ. 1.2 ms
Signal delay when switching on an ohmic nominal load	max. 50 $\mu$ s (in the case of 0.5 A load)
Signal delay when switching off an ohmic nominal load	max. 250 $\mu$ s (in the case of 0.5 A load)
Maximum operating frequency with inductive nominal load	0.5 Hz (1.2 H, 48 $\Omega$ )
Behavior at voltage switch-off	The output follows the power supply without delay
Limitation of the voltage induced on circuit interruption	approx. -30 V
Output current when switched off	max. 10 $\mu$ A (When not loaded, a voltage can be measured even at an output that is not set.)



**Digital outputs**

Behavior with overload	Auto restart
Behavior with inductive overload	Output can be destroyed
Reverse voltage resistance to short pulses	Reverse voltage proof
Resistance to permanent reverse voltage	max. 2 A
Overcurrent shut-down	min. 0.7 A
Short-circuit and overload protection	Freewheeling circuit in the output driver

**Error messages to the higher level control or computer system**

Short-circuit / overload of the digital outputs	Yes
Sensor supply failure	Yes
Failure of the actuator supply	Yes

**Mechanical tests**

Vibration resistance in acc. with EN 60068-2-6/ IEC 60068-2-6	5g
Shock in acc. with EN 60068-2-27/IEC 60068-2-27	Operation: 25g, 11 ms duration, semi-sinusoidal shock impulse

**Conformance with EMC Directive 2014/30/EU**

**Noise immunity test in accordance with EN 61000-6-2**

Electrostatic discharge (ESD) EN 61000-4-2/ IEC 61000-4-2	Criterion B, 6 kV contact discharge, 6 kV air discharge (without marking field) 8 kV air discharge (with marking fields in place)
Electromagnetic fields EN 61000-4-3/IEC 61000-4-3	Criterion A, Field intensity: 10 V/m
Fast transients (burst) EN 61000-4-4/IEC 61000-4-4	Criterion A, all interfaces 1 kV Criterion B, all interfaces 2 kV
Transient overvoltage (surge) EN 61000-4-5/ IEC 61000-4-5	Criterion B, supply lines DC: 0.5 kV/0.5 kV (symmetrical/ asymmetrical), fieldbus cable shield 1 kV
Conducted interference EN 61000-4-6/IEC 61000-4-6	Criterion A; Test voltage 10 V

**Noise emission test as per EN 61000-6-4**

EN 55011	Class A
----------	---------

**Approvals**

For the latest approvals, please visit [phoenixcontact.net/products](http://phoenixcontact.net/products).

## 5 Internal circuit diagram

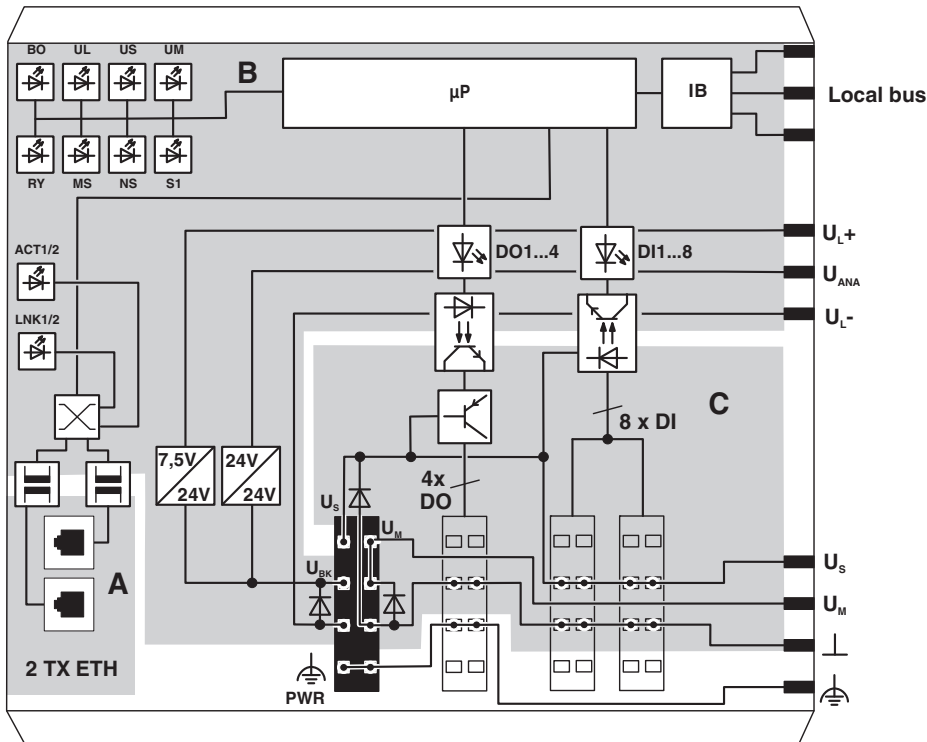











Figure 1 Internal wiring of the terminal points

Key:

	Microprocessor		LED
	Protocol chip		Power supply unit
	Optocoupler		Electrically isolated area
	Ethernet Switch	The gray areas in the basic circuit diagram represent the electrically isolated areas:	
	PNP transistor	A	Ethernet interface
	Transmitter with electrical isolation	B	Logic
		C	I/O devices



Please refer to the IL SYS INST UM E user manual for an explanation of other symbols used.

## 6 Connecting Ethernet, the supply, actuators, and sensors

### 6.1 Connecting Ethernet

Connect Ethernet to the bus coupler via an 8-pos. RJ45 connector.

The Ethernet connections are set to autocrossing (auto crossover).



#### Shielding

The shielding ground of the connected twisted pair cables is electrically connected with the socket. When connecting network segments, avoid ground loops, potential transfers, and voltage equalization currents via the braided shield.



#### Observe bending radii

The housing dimensions specified under "Dimensions" refer to the bus coupler with I/O connectors without Ethernet connection. When installing the bus coupler in a control box, observe the bending radii of the Ethernet cables and the connectors used (e.g., FL CAT5 FLEX: 30 mm for fixed installation and FL CAT5 HEAVY: 30 mm without outer sheath and 45 mm with outer sheath). If required, use angled RJ45 connectors to maintain these bending radii.

### 6.2 Connecting the supply, actuators, and sensors - terminal point assignment

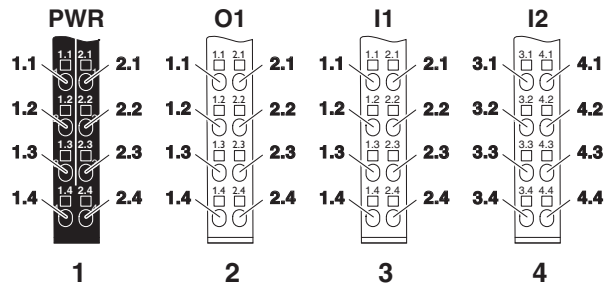

Figure 2 Terminal point assignment

#### Terminal point assignment of the power connector (1)

Terminal point	Assignment	Terminal point	Assignment
1.1	$U_S$	2.1	$U_M$
1.2	$U_{BK}$	2.2	$U_M$
1.3	GND $U_{BK}$	2.3	GND $U_M, U_S$
1.4	Functional earth ground (FE)	2.4	Functional earth ground (FE)



For information on the power supplies, please refer to the IL SYS INST UM E user manual.



If you want to use the same reference potential for communications power and segment voltage, you can bridge the terminal points 1.3 and 2.3 on the connector.



Make sure that the maximum total current flowing through the potential jumpers is 8 A.



Connect the functional earth ground via the power connector.

Terminal point assignment of the output connector (2)

Terminal point	Assignment	Terminal point	Assignment
1.1	OUT1	2.1	OUT2
1.2	GND	2.2	GND
1.3	FE	2.3	FE
1.4	OUT3	2.4	OUT4

Terminal point assignment of the input connector (3)

Terminal point	Assignment	Terminal point	Assignment
1.1	IN1	2.1	IN2
1.2	$U_M$	2.2	$U_M$
1.3	GND	2.3	GND
1.4	IN3	2.4	IN4

Terminal point assignment of the input connector (4)

Terminal point	Assignment	Terminal point	Assignment
3.1	IN5	4.1	IN6
3.2	$U_M$	4.2	$U_M$
3.3	GND	4.3	GND
3.4	IN7	4.4	IN8

7 Connection example

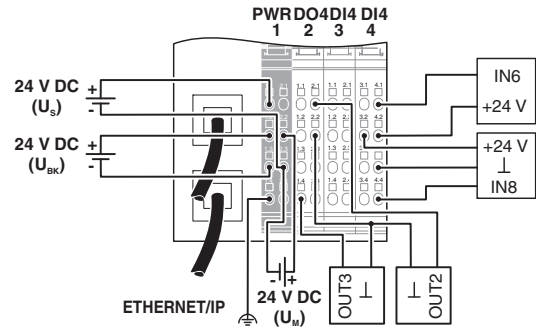

Figure 3 Connection example

## 8 Local diagnostic and status indicators

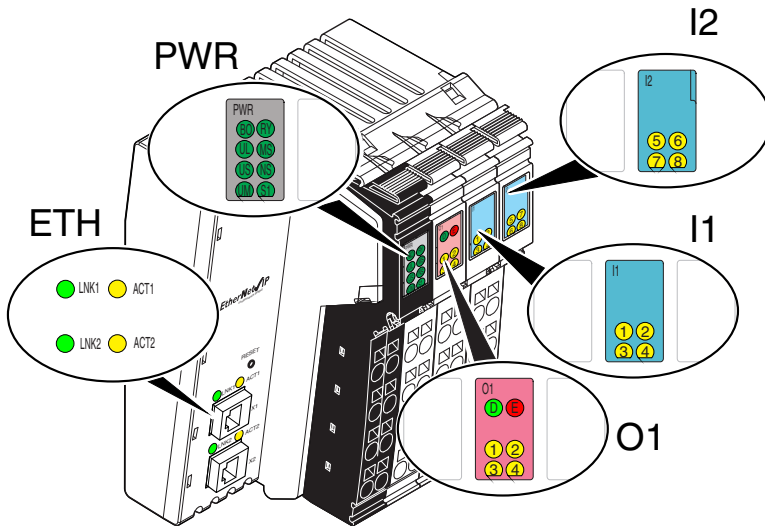

Figure 4 Local diagnostic and status indicators

Designation	Color	Meaning	State	Description
<b>ETH</b>				
LNK 1/2	Green	Link port 1/2	ON	Connection via Ethernet to a module via port 1/2 established
			OFF	No connection established via port 1/2
ACT 1/2	yellow	Activity port 1/2	Flashing	Transmission or reception of Ethernet telegrams at port 1/2
			OFF	No transmission or reception of Ethernet telegrams at port 1/2
<b>PWR/ETH</b>				
BO	Green	Boot	OFF	System startup completed
			Flashing	Waiting for BootP/DHCP reply
			ON	Boot loader active, firmware started
UL	Green	U <sub>Logic</sub>	OFF	24 V bus coupler supply/7.5 V communications power not present
			ON	24 V bus coupler supply/7.5 V communications power present
US	Green	U <sub>Segment</sub>	OFF	24 V segment supply not present
			ON	24 V segment supply is present
UM	Green	U <sub>Main</sub>	OFF	24 V supply is not present in the main circuit
			ON	24 V supply is present in the main circuit
RY	Green	Ready	ON	Connection to a process data client established
			Flashing	Firmware ready to operate
			OFF	Device is not ready for operation.

Designation	Color	Meaning	State	Description
MS	Red/green	Module Status		Device status
			OFF	No supply voltage.
			Flashing red/green	Self test
			Flashing red	Recoverable error
			Green flashing	Device is not configured.
				Device is in standby mode.
			Red ON	Unrecoverable error.
Green ON	Normal operation			
NS	Green/red	Network Status		Network Status
			OFF	Device is not online. Device has not yet finished the "duplicate MAC ID" test. Device has no IP address or is not supplied with voltage.
			Flashing red/green	Self test
			Flashing red	One or more I/O connections have been terminated due to timeout.
			Green flashing	Device is online, but connections have not been established. Device has finished the "duplicate MAC ID" test, but has not established connections to other nodes.
			Red ON	Error that prevents communication with the network (e.g., bus is offline or duplicate MAC ID).
			Green ON	Device is online and has established at least one connection.
S1	Green	Boot Source Status	OFF	The stored IP parameters are used.
			Flashing	BootP requests/responses are being sent.
			ON	IP parameters have been received from the BootP/DHCP server.
<b>O1: diagnostics of the Inline station/diagnostics and status of the outputs</b>				
D	Green	Diagnostics	ON	Data transmission active within the station
			Flashing	Data transmission not active within the station
E	Red	Error	ON	Short circuit/overload at one of the outputs
			OFF	No short circuit/overload at one of the outputs
1 ... 4	Yellow	Status of outputs 1 ... 4	ON	Output is set.
			OFF	Output is not set.
<b>I1, I2: status of the inputs</b>				
1 ... 8	Yellow	Status of the inputs 1 ... 8	ON	Input is active.
			OFF	Input is inactive.

## 9 Reset button

The reset button is on the front of the bus coupler.

The reset button has two functions:

- Restarting the bus coupler
- Resetting of the default settings

### 9.1 Restarting the bus coupler

The bus coupler is restarted when the button is pressed during operation.

The outputs of the station are reset.

The process image of the inputs is not re-read.

### 9.2 Restoring the default settings

The bus coupler is supplied with the following default settings:

#### IP settings

IP address	0.0.0.0
Subnet mask	0.0.0.0
Default gateway	0.0.0.0
BootP	activated

#### Firmware update

Firmware update on next restart	deactivated
TFTP server IP address	0.0.0.0
Name of firmware update file	c2897758.fw

#### System identification

Name of device	IL EIP BK DI8 DO4 2TX-PAC
Description	Ethernet/IP bus terminal
Location	unknown
Contact	unknown

#### Process data monitoring

Process data watchdog time-out	0 (deactivated)
Fault response mode	Reset fault mode (Default)

Plug and play mode	activated
--------------------	-----------

If you wish to restore the default settings, proceed as follows:

- Disconnect the power to the module.
- Press and hold the reset button.
- Switch on the power.
- When the RY LED flashes green, release the button.

The default settings are restored.

## 10 Startup

### 10.1 Starting the firmware



By default, the bus coupler has no valid IP parameters.

The firmware is started after you have supplied power to the bus coupler.

The following LED sequence is displayed:

Display	Meaning
BO flashing	Starting the boot loader Sending BootP requests
BO on	Extracting the firmware
BO off	Starting firmware
RY flashing	Firmware ready to operate

### 10.2 Sending BootP requests

#### Initial startup

During initial startup, the device sends BootP requests without interruption until it receives a valid IP address. The requests are transmitted at varying intervals (2 s, 4 s, 8 s, 2 s, 4 s, etc.) so that the network is not loaded unnecessarily. If valid IP parameters are received, they are saved as configuration data by the device.

#### Restart

By default, the device sends BootP requests for an undefined time until a valid reply is received. This process can be modified so that the device only sends three BootP requests following a restart and reverts to the most recent configuration parameters. For further information, please refer to the “Configuration object” section in the UM EN IL EIP BK DI8 DO4 2TX-PAC user manual.

## 11 Startup behavior of the bus coupler

The startup behavior of the bus coupler is specified via the “Plug&Play” (Plug and Play) system parameter.

There are three different Plug and Play modes:

- Inputs only
- Inputs and outputs (activated by default)
- Disabled

The Plug and Play mode status (Inputs only, Inputs and outputs, and Disabled) is stored retentively on the bus coupler.

The current mode can be accessed via the WBM interface or the CIP interface.

#### “Inputs only” Plug and Play mode activated

This mode enables Inline terminals connected in the field to be started up using the bus coupler without a higher-level configuration.

In this mode, the connected Inline terminals are detected and their operating ability is checked. If this physical configuration is ready to operate, it is started, however the writing of outputs is not enabled.

To enable the writing of outputs, Plug and Play mode must either be deactivated or set to “Inputs and outputs”.

The deactivation of Plug and Play mode is also the signal to save the active configuration as the reference configuration.

#### “Inputs and outputs” Plug and Play mode activated

Outputs can be written in this mode. The greatest possible care should always be taken when setting this mode.



#### NOTE: Malfunction

An I/O system configuration that is incorrectly assigned to termination devices, such as drive controllers or motion controllers, can result in malfunctions when the outputs are activated.

In this mode, make sure that all connected termination devices are working properly when the outputs are enabled.



**Plug and play mode inactive**

When Plug and Play mode is deactivated, the reference configuration is compared to the physical configuration. If they are the same, the bus coupler is set to the RUN state on the first write access.

If the reference configuration and the physical configuration differ, the MS LED lights up and process data exchange is not possible for safety reasons.

In order to operate the bus despite this, you have the following two options:

1. Restore the original configuration so that the reference configuration and the physical configuration are the same again.
2. Activate Plug and Play mode and restart the bus coupler so that the active physical configuration is accepted as the reference configuration.

Plug and Play mode	Description
Disabled	Normal scenario - the station sets valid configurations to the "RUN" state. Process data exchange is possible.
Inputs only	The connected configuration is stored as the reference configuration and the station is set to the "RUN" state. Process data cannot be written.
Inputs and outputs	The connected configuration is stored as the reference configuration and the station is set to the "RUN" state. Process data exchange is possible.

**11.1 Startup diagrams for the bus coupler**

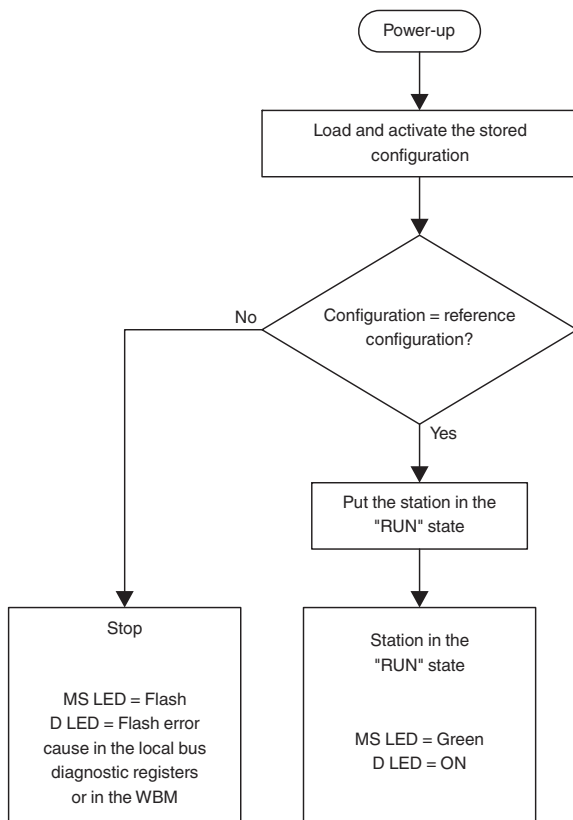

Figure 5 Normal mode. Plug and play mode inactive

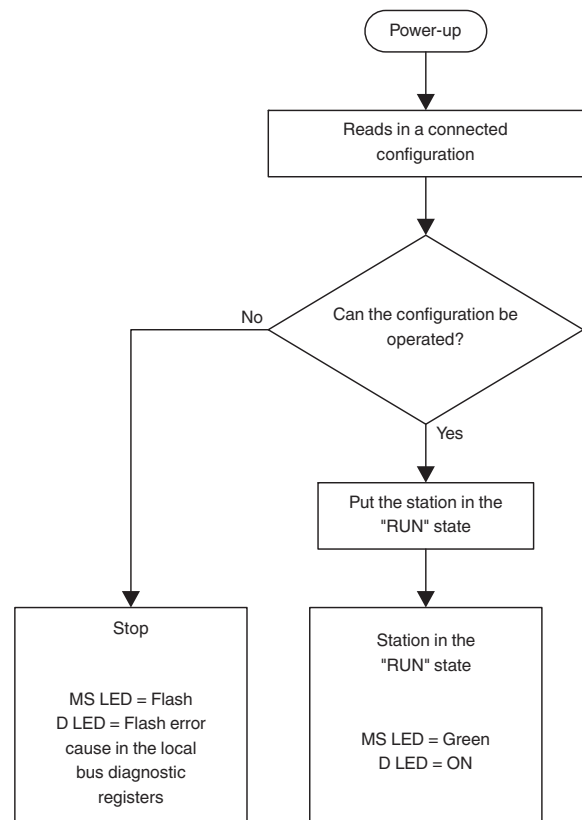

Figure 6 Plug and play mode activated

## 12 EtherNet/IP™ object classes

The device supports the Common Industrial Protocol (CIP) by using digital input points (DIPs), digital output points (DOPs), analog input points (AIPs), and analog output points (AOPs) according to the ODVA specification.

Additional objects include user-defined configuration, Inline interface, Inline module, Inline special function objects, PCP special function objects, and serial communication objects.

CIP and EtherNet/IP™ are standardized by the ODVA on a manufacturer-neutral basis.

The Common Industrial Protocol is an object-oriented protocol with two different types of communication between a controller and termination devices.

The following table describes the two communication types.

Connection type	Description
Explicit messaging	This means that a controller or an engineering system sends a request and the termination device responds. For example, explicit messaging can be used for configuration and/or diagnostics.
Implicit messaging	Implicit messaging is used for the cyclic transmission of I/O data. That means, for example, that a termination device sends an analog value which is present at a termination device input. The time for a transmission cycle can be set via the requested packet interval (RPI).

### 12.1 CIP class and instance services

The device supports the following class services and instance services:

Service code		Service name
dec	hex	
01	01	Get_Attribute_All
02	02	Set_Attribute_All
05	05	Reset
14	0E	Get_Attribute_Single
16	10	Set_Attribute_Single

### 12.2 CIP object classes

The device supports the following CIP object classes:

Class code		Object type
dec	hex	
01	01	Identity object
02	02	Router object
04	04	Assembly object
05	05	Connection object
06	06	Connection manager object
08	08	Digital input point object
09	09	Digital output point object
10	0A	Analog input point object
11	0B	Analog output point object
43	2D	Acknowledge handler object
100	64	Configuration object
101	65	Inline interface object
102	66	Inline module object
103	67	Inline special function object
104	68	COS mask object
105	69	PCP object
106	6A	Serial object
244	F4	Port object
245	F5	TCP/IP interface object
246	F6	Ethernet link object



For a detailed description of all objects, please refer to the UM EN IL EIP BK DI8 DO4 2TX-PAC user manual.

## 13 Operating guidelines for the system

### 13.1 “Repeat packet interval (RPI)” settings

- Configurations requiring RPI rates below 10 ms should first be tested for correct operation.
- Configurations requiring PCP modules should use RPI settings of at least 20 ms. Settings below 20 ms should be tested first.

### 13.2 Maximum connections

The module firmware supports up to 128 connections in total (any combination of implicit and explicit). Special features of the application, such as CPU load, data update frequency (RPI parameters), and scanned I/O quantity, affect the maximum number of connections. A lower number of connections enables faster scanned data update and therefore influences the maximum number of connections. A lower number of connections enables faster data update (RPI value). For maximum I/O performance, the number of connections should be limited to no more than eight.

## 14 WBM - Web-based management

The device has a web server, which generates the required pages for web-based management and, depending on the requirements of the user, sends them to a standard web browser.

Web-based management can be used to access static information (e.g., technical data, MAC address) or dynamic information (e.g., IP address, status information, local bus structure, and local bus diagnostics).

### Calling web-based management

The device web server can be addressed using the IP address if configured accordingly. The homepage (web page) of the device is accessed by entering the URL “http://ip-address”.

Example: http://172.16.113.38



If you cannot access the WBM pages, check the connection settings in your browser and deactivate the proxy, if set.

## 15 Configuration of the PDU size for PCP

The standard PDU size for communication with all Phoenix Contact Inline devices is 64 bytes in the send and receive direction.

System couplers such as the ILC 200 UNI-PAC have configurable PDU sizes. If another size is configured here and the bus coupler is used for communication, the bus coupler must also be configured to the values set on the ILC 200 UNI-PAC.

The PDU sizes can be configured via web-based management.