



Chipsmall Limited consists of a professional team with an average of over 10 year of expertise in the distribution of electronic components. Based in Hongkong, we have already established firm and mutual-benefit business relationships with customers from,Europe,America and south Asia,supplying obsolete and hard-to-find components to meet their specific needs.

With the principle of “Quality Parts,Customers Priority,Honest Operation,and Considerate Service”,our business mainly focus on the distribution of electronic components. Line cards we deal with include Microchip,ALPS,ROHM,Xilinx,Pulse,ON,Everlight and Freescale. Main products comprise IC,Modules,Potentiometer,IC Socket,Relay,Connector.Our parts cover such applications as commercial,industrial, and automotives areas.

We are looking forward to setting up business relationship with you and hope to provide you with the best service and solution. Let us make a better world for our industry!



Contact us

Tel: +86-755-8981 8866 Fax: +86-755-8427 6832

Email & Skype: info@chipsmall.com Web: www.chipsmall.com

Address: A1208, Overseas Decoration Building, #122 Zhenhua RD., Futian, Shenzhen, China



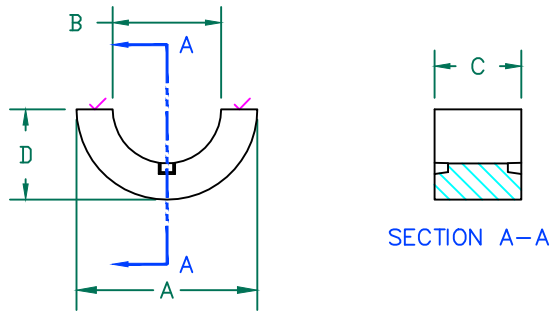

SECTION A-A

CORE (28A4155-000)

FERRITE CORE DIMENSIONS (SPEC): mm [in]

A	25.00 [.984]	±	REF.
B	15.00 [.591]	±	REF.
C	12.00 [.472]	±	REF.
D	12.50 [.492]	±	REF.



UNCONTROLLED DOCUMENT

IMPEDANCE (Z)			
Frequency	25 MHz	100 MHz	300 MHz
Nominal (REF)	50 Ω	120 Ω	230 Ω
Minimum	- Ω	96 Ω	- Ω

Z vs. FREQUENCY
(REF. ONLY)

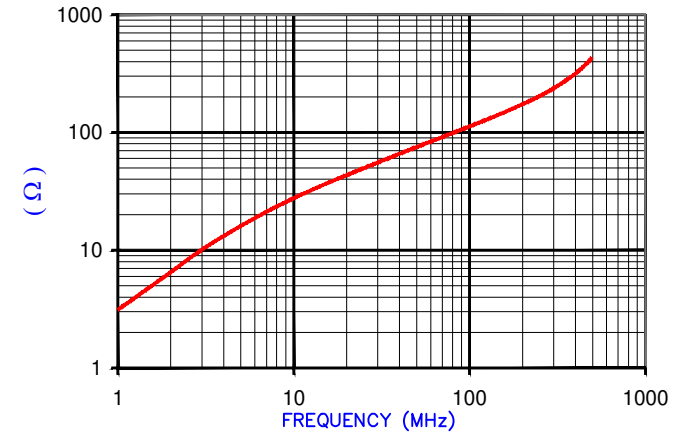

AGILENT E4991A Impedance/Material Analyzer
HP 16092A-Test Fixture REF 3147

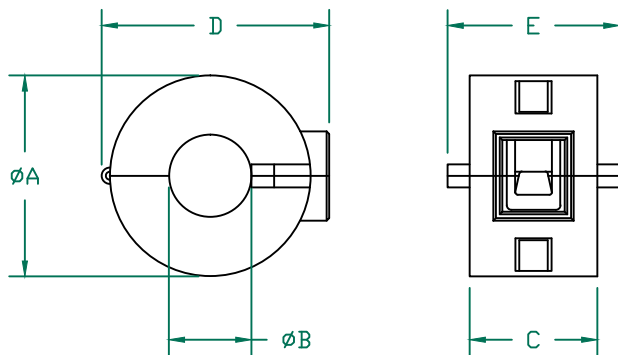

CASE (A4155-0C2)

CASE DIMENSIONS (SPEC): mm [in]

A	28.80 [1.134]	±	0.40 [.016]
B	13.60 [.535]	±	0.40 [.016]
C	15.40 [.606]	±	0.30 [.012]
D	33.20 [1.307]	±	0.50 [.020]
E	21.80 [.858]	±	0.60 [.024]

NOTES:

- CASE UL FLAMMABILITY RATING: 94 V-0
- ASSEMBLED PART #: 28A4155-0A2
- FOR CORE DIMENSIONS SEE STEWARD P/N 28A4155-000.
- FOR CASE DIMENSIONS SEE STEWARD P/N A4155-0C2.
- CASE COLOR: -0A2 BLACK CASE.
- COSMETIC SPECIFICATION REFER TO WI-QA-038.

DIMENSIONS ARE IN mm [INCHES].				This print is the property of Laird Tech. and is loaned in confidence subject to return upon request and with the understanding that no copies shall be made without the written consent of Laird Tech. All rights to design or invention are reserved.				
REV	DESCRIPTION	DATE	INT					
J	UPDATE COMPANY LOGO ,ADD NOTE 6	08/23/14	QIU	PROJECT/PART NUMBER: 28A4155-0A2		REV	PART TYPE:	DRAWN BY:
H	UPDATE CASE TOLERANCES UPDATE COMPANY LOGO	05/08/08	TMB			J	FERRITE SNAP-ON	TMB
G	UPDATE Z SPEC & COMPANY LOGO	06/26/07	JRK	DATE: 06/27/01		SCALE:	MATERIAL:	
F	CHG Z SPECS@100MHZ ADD TEST REF#	12/21/04	JRK			NTS	Ferrite	
E	CHANGE P/N FROM -0A* TO -0A2 REVISE NOTES 2, 4, & 5	08/15/03	TMB	CAD # 28A4155-0A2-J		TOOL #		
D	CHANGE PRINT FORMAT CHANGE Z SPECS AND ADD CURVE REVISE NOTE 3,4,& 5 REMOVE CORE DIMS E, F, G, & DET. "A"	07/01/03	TMB			-		
REV	DESCRIPTION	DATE	INT					