



Chipsmall Limited consists of a professional team with an average of over 10 year of expertise in the distribution of electronic components. Based in Hongkong, we have already established firm and mutual-benefit business relationships with customers from,Europe,America and south Asia,supplying obsolete and hard-to-find components to meet their specific needs.

With the principle of “Quality Parts,Customers Priority,Honest Operation,and Considerate Service”,our business mainly focus on the distribution of electronic components. Line cards we deal with include Microchip,ALPS,ROHM,Xilinx,Pulse,ON,Everlight and Freescale. Main products comprise IC,Modules,Potentiometer,IC Socket,Relay,Connector.Our parts cover such applications as commercial,industrial, and automotives areas.

We are looking forward to setting up business relationship with you and hope to provide you with the best service and solution. Let us make a better world for our industry!



Contact us

Tel: +86-755-8981 8866 Fax: +86-755-8427 6832

Email & Skype: info@chipsmall.com Web: www.chipsmall.com

Address: A1208, Overseas Decoration Building, #122 Zhenhua RD., Futian, Shenzhen, China



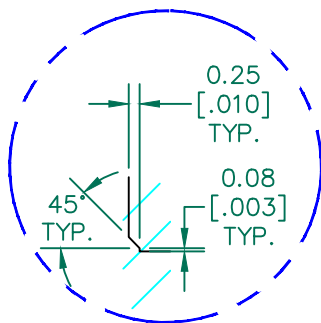
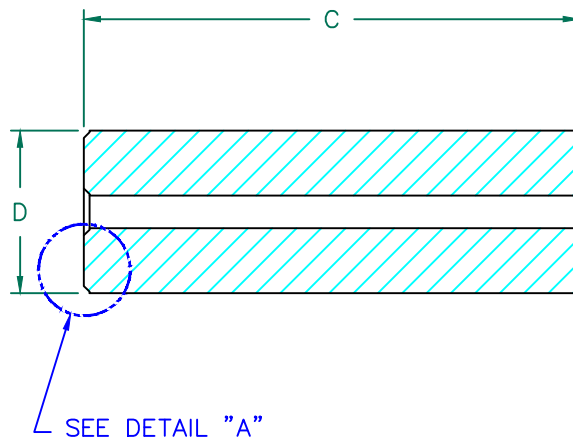
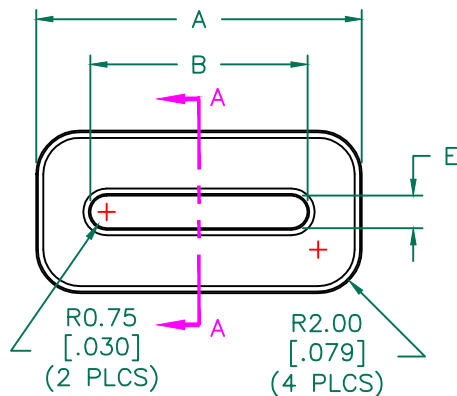

DETAIL "A"
CHAMFER
SCALE=6:1

UNCONTROLLED DOCUMENT

IMPEDANCE (Z)			
Frequency	25 MHz	100 MHz	300 MHz
Nominal (REF)	121 Ω	227 Ω	370 Ω
Minimum	- Ω	182 Ω	- Ω

Z vs. FREQUENCY
(REF. ONLY)

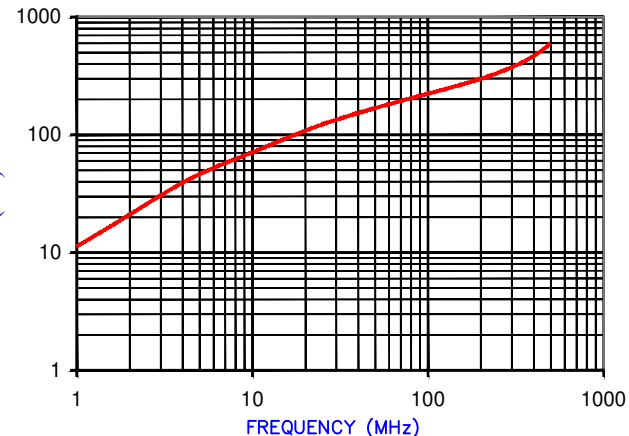

AGILENT E4991A Impedance/Material Analyzer
HP 16092A-Test Fixture, REF # 2964

FERRITE CORE DIMENSIONS (SPEC): mm [in]

A	15.01 [.591]	+	0.38 [.015]
B	10.00 [.394]	+	0.25 [.010]
C	22.86 [.900]	+	0.50 [.020]
D	7.49 [.295]	+	0.25 [.010]
E	1.50 [.059]	+	0.25 [.010]

WEIGHT/1000 10.66 kgs [23.51 Lbs]

NOTES: UNLESS OTHERWISE SPECIFIED

1. COSMETIC SPECIFICATION REFER TO WI-QA-038.

SCALE DRAWING 1:1



28R0592-010



DIMENSIONS ARE IN mm[INCHES].				This print is the property of Laird Tech. and is loaned in confidence subject to return upon request and with the understanding that no copies shall be made without the written consent of Laird Tech. All rights to design or invention are reserved.			
REV	DESCRIPTION	DATE	INT				
J	UPDATE COMPANY LOGO	05/25/15	QIU	PROJECT/PART NUMBER: 28R0592-010		REV J	DRAWN BY: BAC
H	UPDATE Z SPEC AND COMPANY LOGO	07/26/07	JRK				
G	ADD TEST REF #, CHG MIN Z SPEC	11/12/04	JRK				
F	CHANGE PRINT FORMAT CHANGE Z SPECS	05/06/03	TMB				
E	ADD ZRX CURVE TO PRINT REVISE PART LAYOUT FORMAT REVISE ELECTRICAL TESTING FORMAT AND WEIGHT/1000 kgs [Lbs] CHANGE CHAMFER DEPTH FROM .020 TO .010 & ADD OD CHAMFER	07/18/02	TMB	DATE: 07/24/96		SCALE: 3 : 1	MATERIAL: FERRITE
D	UPDATE FORMAT ADD CHAMFER DETAIL UPDATE Z SPECS, IMPEDANCE TESTED	02/25/02	JRK	TOOL # R0592			
C	UPDATE CUSTOMER P/N & REV	09/04/96	BAC	CAD # 28R0592-010-J			
REV	DESCRIPTION	DATE	INT	28R0592-010-J			