



Chipsmall Limited consists of a professional team with an average of over 10 year of expertise in the distribution of electronic components. Based in Hongkong, we have already established firm and mutual-benefit business relationships with customers from,Europe,America and south Asia,supplying obsolete and hard-to-find components to meet their specific needs.

With the principle of “Quality Parts,Customers Priority,Honest Operation,and Considerate Service”,our business mainly focus on the distribution of electronic components. Line cards we deal with include Microchip,ALPS,ROHM,Xilinx,Pulse,ON,Everlight and Freescale. Main products comprise IC,Modules,Potentiometer,IC Socket,Relay,Connector.Our parts cover such applications as commercial,industrial, and automotives areas.

We are looking forward to setting up business relationship with you and hope to provide you with the best service and solution. Let us make a better world for our industry!



Contact us

Tel: +86-755-8981 8866 Fax: +86-755-8427 6832

Email & Skype: info@chipsmall.com Web: www.chipsmall.com

Address: A1208, Overseas Decoration Building, #122 Zhenhua RD., Futian, Shenzhen, China



MINI MCR-2-TC-UI(-PT)(-C)

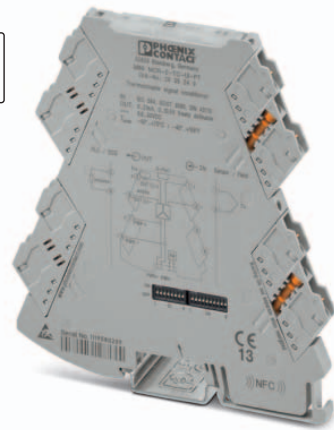

Temperature transducers for thermocouples

Data sheet
106016_en_03

© PHOENIX CONTACT 2017-01-25

1 Description

Configurable 3-way isolated temperature transducer with pluggable connection technology. The device is suitable for the connection of thermocouples.

The measured values are converted into a linear and freely configurable current or voltage signal.

Features

- Configurable, 3-way isolated temperature transducer with plug-in connection technology.
- 15 default thermocouple types
- Additional types can be set by means of user characteristic curves
- Approval for Ex-zone 2 (nA)
- Screw or push-in connection available
- Can be supplied configured or unconfigured
- Reinforced insulation according to IEC 61010-1
- Supply voltage range 9.6 ... 30 V DC



WARNING: Correct usage in potentially explosive areas

The module is a category 3 item of electrical equipment. It is absolutely vital to follow the instructions provided here during installation and observe the information in the "Safety regulations and installation notes".



This device offers the option of NFC communication.

You can use the MINI Analog Pro Smartphone app via the NFC interface of your Smartphone to configure the device and to call-up DIP switch setting help and comprehensive module information.

The MINI Analog Pro Smartphone app is available to you free.



Make sure you always use the latest documentation.

It can be downloaded from the product at phoenixcontact.net/products.

This document is valid for the products listed in the "Ordering data".

2	Table of contents	
1	Description	1
2	Table of contents	2
3	Ordering data	3
4	Technical data	6
5	Safety regulations and installation notes.....	9
	5.1 Installation notes	9
	5.2 Installation in Zone 2.....	9
	5.3 UL Notes	9
6	Installation	10
	6.1 Connection notes	10
	6.2 Structure	10
	6.3 Block diagram.....	10
	6.4 Power supply.....	10
	6.5 Assembly.....	11
	6.6 FASTCON Pro plugs	11
	6.7 Fault monitoring FM	12
	6.8 Current measurement	12
	6.9 Marking.....	12
7	Configuration	13
	7.1 Configuration via DIP switches	13
	7.2 Configuration via software.....	16
	7.3 Configuration via MINI Analog Pro app.....	16
8	Function description	17
	8.1 Notes on using thermocouples.....	17
	8.2 Analog switching output	18
	8.3 Monitoring.....	18
	8.4 Limiting behavior of the analog output.....	18
	8.5 Diagnostic functions and error messages	18
	8.6 Simulation mode/force	18
9	Diagnostics and status indicators	19

3 Ordering data

Description	Type	Order No.	Pcs./Pkt.
Configurable temperature transducer with plug-in connection technology for connecting thermocouples. Configurable via DIP switch or software. Screw connection technology, standard configuration	MINI MCR-2-TC-UI	2902055	1
Configurable temperature transducer with plug-in connection technology for connecting thermocouples. Configurable via DIP switch or software. Push-in connection technology, standard configuration	MINI MCR-2-TC-UI-PT	2905249	1
Configurable temperature transducer with plug-in connection technology for connecting thermocouples. Configurable via DIP switch or software. Screw connection technology, order configuration	MINI MCR-2-TC-UI-C	2902053	1
Configurable temperature transducer with plug-in connection technology for connecting thermocouples. Configurable via DIP switch or software. Push-in connection technology, order configuration	MINI MCR-2-TC-UI-PT-C	2905248	1
Accessories	Type	Order No.	Pcs./Pkt.
Programming adapter with USB interface, for programming with software. The USB driver is included in the software solutions for the products to be programmed, such as measuring transducers or motor managers.	IFS-USB-PROG-ADAPTER	2811271	1
DIN rail connector for DIN rail mounting. Universal for TBUS housing. Gold-plated contacts, 5-pos. Plug component, Number of positions: 5, Pitch: 3.81 mm	ME 6,2 TBUS-2 1,5/5-ST-3,81 GN	2869728	10
Power terminal with plug-in connection technology for delivering the supply voltage to the DIN rail connector. Monitoring of the supply voltages in combination with the fault monitoring module. Screw connection technology	MINI MCR-2-PTB	2902066	1
Power terminal with plug-in connection technology for delivering the supply voltage to the DIN rail connector. Monitoring of the supply voltages in combination with the fault monitoring module. Push-in connection technology	MINI MCR-2-PTB-PT	2902067	1
Fault monitoring module with plug-in connection technology for evaluating and reporting group errors from the FM system and for monitoring the supply voltages. Error reporting via N/O contact. Screw connection technology, standard configuration	MINI MCR-2-FM-RC	2904504	1
Fault monitoring module with plug-in connection technology for evaluating and reporting group errors from the FM system and for monitoring the supply voltages. Error reporting via N/O contact. Push-in connection technology, standard configuration	MINI MCR-2-FM-RC-PT	2904508	1
Primary-switched MINI POWER supply for DIN rail mounting, input: 1-phase, output: 24 V DC/1.5 A	MINI-SYS-PS-100-240AC/24DC/1.5	2866983	1

Accessories	Type	Order No.	Pcs./Pkt.
Marker for end clamp, Sheet, white, unlabeled, can be labeled with: THERMOMARK PRIME, THERMOMARK CARD, BLUEMARK CLED, BLUEMARK LED, TOPMARK LASER, Mounting type: snapped into marker carrier, Lettering field: 30 x 5 mm	UCT-EM (30X5)	0801505	10
Marker for end clamp, can be ordered: by sheet, white, labeled according to customer specifications, Mounting type: snapped into marker carrier, Lettering field: 30 x 5 mm	UCT-EM (30X5) CUS	0801589	1
Marker for end clamp, Sheet, yellow, unlabeled, can be labeled with: THERMOMARK PRIME, THERMOMARK CARD, BLUEMARK CLED, BLUEMARK LED, TOPMARK LASER, Mounting type: snapped into marker carrier, Lettering field: 30 x 5 mm	UCT-EM (30X5) YE	0830340	10
Marker for end clamp, can be ordered: by sheet, yellow, labeled according to customer specifications, Mounting type: snapped into marker carrier, Lettering field: 30 x 5 mm	UCT-EM (30X5) YE CUS	0830348	1
Plastic label, Sheet, white, unlabeled, can be labeled with: BLUEMARK CLED, BLUEMARK LED, CMS-P1-PLOTTER, PLOTMARK, Mounting type: Adhesive, Lettering field: 15 x 5 mm	UC-EMLP (15X5)	0819301	10
Plastic label, Sheet, white, unlabeled, can be labeled with: BLUEMARK CLED, BLUEMARK LED, CMS-P1-PLOTTER, THERMOMARK CARD, THERMOMARK PRIME, PLOTMARK, Mounting type: Adhesive, Lettering field: 15 x 5 mm	UC-EMLP (15X5)L	0820138	5
Plastic label, Sheet, yellow, unlabeled, can be labeled with: BLUEMARK CLED, BLUEMARK LED, CMS-P1-PLOTTER, PLOTMARK, Mounting type: Adhesive, Lettering field: 15 x 5 mm	UC-EMLP (15X5) YE	0822615	10
Plastic label, can be ordered: by sheet, white, labeled according to customer specifications, Mounting type: Adhesive, Lettering field: 15 x 5 mm	UC-EMLP (15X5) CUS	0824550	1
Plastic label, can be ordered: by sheet, yellow, labeled according to customer specifications, Mounting type: Adhesive, Lettering field: 15 x 5 mm	UC-EMLP (15X5) YE CUS	0824551	1
Plastic label, can be ordered: by sheet, white, labeled according to customer specifications, Mounting type: Adhesive, Lettering field: 15 x 5 mm	UC-EMLP (15X5)L CUS	0824552	1
Plastic label, Sheet, yellow, unlabeled, can be labeled with: BLUEMARK CLED, BLUEMARK LED, CMS-P1-PLOTTER, Mounting type: Adhesive, Lettering field: 15 x 5 mm	UC-EMLP (15X5)L YE	0825325	5
Plastic label, can be ordered: by sheet, yellow, labeled according to customer specifications, Mounting type: Adhesive, Lettering field: 15 x 5 mm	UC-EMLP (15X5)L YE CUS	0826680	1
Plastic label, Sheet, silver, unlabeled, can be labeled with: BLUEMARK CLED, BLUEMARK LED, CMS-P1-PLOTTER, PLOTMARK, Mounting type: Adhesive, Lettering field: 15 x 5 mm	UC-EMLP (15X5) SR	0828095	10
Plastic label, can be ordered: by sheet, silver, labeled according to customer specifications, Mounting type: Adhesive, Lettering field: 15 x 5 mm	UC-EMLP (15X5) SR CUS	0828099	1

Accessories	Type	Order No.	Pcs./Pkt.
Plastic label, Sheet, silver, unlabeled, can be labeled with: BLUEMARK CLED, BLUEMARK LED, CMS-P1-PLOTTER, PLOTMARK, Mounting type: Adhesive, Lettering field: 15 x 5 mm	UC-EMLP (15X5)L SR	0828103	5
Marker strip, Roll, white, unlabeled, can be labeled with: THERMOMARK ROLL, THERMOMARK ROLL X1, THERMOMARK ROLLMASTER 300/600, THERMOMARK X1.2, THERMOMARK S1.1, Mounting type: Adhesive, Lettering field: continuous x 5 mm	SK 5,0 WH:REEL	0805221	1
DIN rail connector (TBUS), 5-pos., for bridging the supply voltage, can be snapped onto NS 35/... DIN rails according to EN 60715	ME 6,2 TBUS-2 1,5/5-ST-3,81 GY	2695439	10
Bluetooth programming adapter with μ USB and S-PORT interface for wireless programming and monitoring. The driver is included in the software solutions for the products to be programmed, such as measuring transducers or motor managers.	IFS-BT-PROG-ADAPTER	2905872	1

4 Technical data

Input	
Configurable/programmable	Yes
Sensor type	B, C, E, J, K, N, R, S, T, L, U, A-1, A-2, A-3, M, L
Temperature measuring range	-250 °C ... 2500 °C (Range depends on sensor type, range can be set freely via software or in increments from -150°C to 1350°C via DIP switches)
Measuring range span	min. 50 K
Number of inputs	1
Output	
Number of outputs	1
Voltage output signal	0 V ... 5 V (via DIP switch) 1 V ... 5 V (via DIP switch) 0 V ... 10 V (via DIP switch) 10 V ... 0 V (via DIP switch) 0 V ... 10.5 V (Can be set via software)
Max. voltage output signal	approx. 12.3 V
Short-circuit current	< 31.5 mA
Current output signal	0 mA ... 20 mA (via DIP switch) 4 mA ... 20 mA (via DIP switch) 20 mA ... 0 mA (via DIP switch) 20 mA ... 4 mA (via DIP switch) 0 mA ... 21 mA (Can be set via software)
Max. current output signal	24.6 mA
Non-load voltage	< 17.5 V
Configurable/programmable	Yes
Load/output load voltage output	≥ 10 kΩ
Ripple	< 10 mV _{rms}
Load/output load current output	≤ 600 Ω (at 20 mA)
Resolution, outputs (voltage)	1 mV
Resolution, outputs (current)	2 μA
Supply	
Supply voltage range	9.6 V DC ... 30 V DC (The DIN rail bus connector (ME 6,2 TBUS-2 1,5/5-ST-3,81 GN, Order No. 2869728) can be used to bridge the supply voltage. It can be snapped onto a 35 mm DIN rail according to EN 60715))
Typical current consumption	32.7 mA (24 V DC) 66.8 mA (12 V DC)
Power consumption	≤ 850 mW (at I _{OUT} = 20 mA, 9.6 V DC, 600 Ω load)
Status and diagnostics indicators	
Indication	Red LED
Operating voltage display	Green LED

General data		
Transmission error thermocouples	0.1% * 600 K / set measuring range; 0.1% > 600 K (C, E, J, K, N, T, L, U, M Gost, L Gost) 0.2 % * 600 K / set measuring range; 0.2 % > 600 K (B, R, S, A1, A2, A3) 0.2% * 600 K / set measuring range; 0.2% > 600 K (E, J, K, N, T, L, U, M Gost, L Gost); Highspeed Mode 0.4% * 600 K / set measuring range; 0.4% > 600 K (B, R, S, A1, A2, A3); Highspeed Mode	
Maximum temperature coefficient	≤ 0.01 %/K	
Step response (0–99%)	typ. 400 ms (Highspeed Mode: typ. 150 ms)	
Typical cold point errors	2 K (2 K + (0,2 K * ΔT))	
Electrical isolation	Reinforced insulation in accordance with IEC 61010-1	
Overvoltage category	II	
Mounting position	any	
Degree of protection	IP20	
Degree of pollution	2	
Rated insulation voltage	300 V (effective)	
Test voltage, input/output/supply	3 kV (50 Hz, 1 min.)	
Dimensions W/H/D	6.2 mm / 110.5 mm / 120.5 mm	
Type of housing	PBT	
Connection data	Screw connection	Push-in connection
Solid conductor cross section with ferrule	0.2 mm ² ... 1.5 mm ²	0.14 mm ² ... 2.5 mm ²
Solid conductor cross section without ferrule	0.2 mm ² ... 2.5 mm ²	0.14 mm ² ... 2.5 mm ²
Conductor cross section, flexible	0.2 mm ² ... 1.5 mm ²	0.14 mm ² ... 2.5 mm ²
Conductor cross section AWG	24 ... 12	24 ... 12
Stripping length	10 mm	10 mm
Ambient conditions		
Ambient temperature (operation)	-40 °C ... 70 °C	
Ambient temperature (storage/transport)	-40 °C ... 85 °C	
Permissible humidity (operation)	5 % ... 95 % (non-condensing)	
Conformance with EMC directive		
Noise immunity according to EN 61000-6-2 When being exposed to interference, there may be minimal deviations.		
Noise emission according to EN 61000-6-4		

Conformance/Approvals

Conformance	CE-compliant
ATEX	⊕ II 3 G Ex nA IIC T4 Gc X
UL, USA/Canada	UL 508 Listed
UL, USA/Canada	Class I, Div. 2, Groups A, B, C, D T6
UL, USA/Canada	Class I, Zone 2, Group IIC T6
Shipbuilding DNV GL 14445-15HH	C, EMC2

5 Safety regulations and installation notes

5.1 Installation notes

- The category 3 device is suitable for installation in potentially explosive area zone 2. It fulfills the requirements of EN 60079-0:2012 and EN 60079-15:2010.
- Installation, operation, and maintenance may only be carried out by qualified electricians. Follow the installation instructions as described. When installing and operating the device, the applicable regulations and safety directives (including national safety directives), as well as generally approved technical regulations, must be observed. The safety data is provided in this package slip and on the certificates (conformity assessment, additional approvals where applicable).
- While the devices are in operation, contact-dangerous voltages may be present on the control elements. For this reason parameterization, conductor connection, and opening of the module lid are allowed only when devices are in a de-energized state unless the connected circuits are exclusively SELV or PELV circuits.
- The device must not be opened or modified. Do not repair the device yourself, replace it with an equivalent device. Repairs may only be carried out by the manufacturer. The manufacturer is not liable for damage resulting from violation.
- The IP20 protection (IEC 60529/EN 60529) of the device is intended for use in a clean and dry environment. The device must not be subject to mechanical strain and/or thermal loads, which exceed the limits described.
- The device is not designed for use in atmospheres with a danger of dust explosions.
- The device complies with the EMC regulations for industrial areas (EMC class A). When using the device in residential areas, it may cause radio interference.
- If the device is not used as described in the documentation, the intended protection can be negatively affected.
- To protect the device against mechanical or electrical damage, install it in a suitable housing with appropriate degree of protection as per IEC 60529.
- Provide a switch/circuit breaker close to the device, which is labeled as the disconnecting device for this device.
- Provide for a overcurrent protection device ($I \leq 4 \text{ A}$) in the installation.
- There is a double isolation of $300 \text{ V}_{\text{eff}}$ between neighboring modules of the same type oriented the same way. The device has a base isolation of $150 \text{ V}_{\text{eff}}$ to other neighboring modules on the side with the DIP switch.
- The voltages present at the input, output and supply are extra-low voltages (ELV). Depending on the application, dangerous voltage ($> 30 \text{ V}$) against ground could occur. For this event, safe electrical isolation from the other connections has been implemented.

- The device must be stopped if it is damaged, has been subjected to an impermissible load, stored incorrectly, or if it malfunctions.
- Only use copper connecting cables providing the permitted temperature range ($60^\circ\text{C}/75^\circ\text{C}$).

5.2 Installation in Zone 2

- Observe the specified conditions for use in potentially explosive areas! Install the device in a suitable approved housing (with a minimum of IP54 protection) that meets the requirements of EN 60079-15. Observe the requirements of EN 60079-14.
- Only devices which are designed for operation in Ex zone 2 and are suitable for the conditions at the installation location may be connected to the circuits in the Ex zone.
- In potentially explosive areas, terminals may only be snapped onto or off the DIN rail connector and wires may only be connected or disconnected when the power is switched off.
- The device must be stopped and immediately removed from the Ex area if it is damaged, was subject to an impermissible load, stored incorrectly or if it malfunctions.

5.3 UL Notes

INDUSTRIAL CONTROL EQUIPMENT FOR HAZARDOUS LOCATIONS 45FP

- 1 Suitable for use in class 1, division 2, groups A, B, C and D hazardous locations, or nonhazardous locations only.
- 2 **WARNING - EXPLOSION HAZARD:** Do not disconnect equipment unless power has been removed or the area is known to be non-hazardous.
- 3 **WARNING - EXPLOSION HAZARD:** Substitution of any components may impair suitability for Class I, Division 2.
- 4 This device is open-type and is required to be installed in an enclosure suitable for the environment and can only be accessed with the use of a tool or key.

6 Installation

6.1 Connection notes



The device contains components that can be damaged or destroyed by electrostatic discharge. When handling the device, observe the necessary safety precautions against electrostatic discharge (ESD) according to EN 61340-5-1 and IEC 61340-5-1.

6.2 Structure

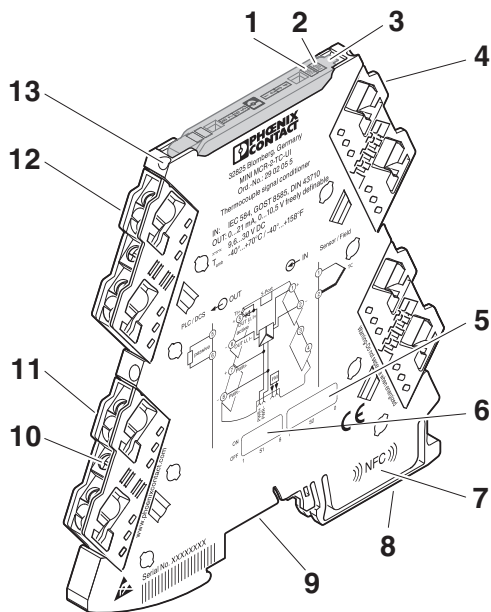

Figure 1 Structure

- 1 Error indicator "ERR" red LED
- 2 Green "PWR" LED, power supply
- 3 Cover with labeling option
- 4 Input: thermocouple
- 5 DIP switch S2
- 6 DIP switch S1
- 7 NFC coil
- 8 Universal snap-on foot for EN DIN rails
- 9 Connection for DIN rail connector
- 10 Spindle screw
- 11 Supply voltage
- 12 Output: Standard signals
- 13 Current measuring socket

6.3 Block diagram

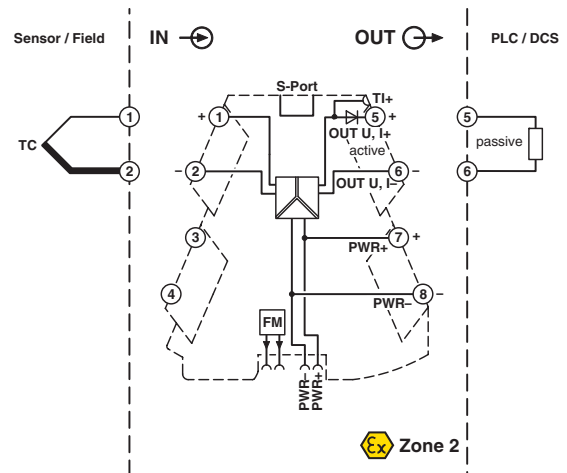

Figure 2 Block diagram

6.4 Power supply

You must refer to the MACX and MINI Analog power manual for the design of the power supply.



NOTE

Never connect the supply voltage directly to the DIN rail connector. Drawing power from individual devices is not permitted!

Supply via the module

Where the total current consumption of the aligned modules does not exceed 400 mA, the power can be supplied directly at the connection terminal blocks of the module.

We recommend connecting a 630 mA fuse (normal-blow or slow-blow) upstream.

Supply via a power terminal block

The MINI MCR-2-PTB power terminal block (Order No. 2902066) or the MINI MCR-2-PTB-PT power terminal block (Order No. 2902067) of the same shape is used to supply the supply voltage to the DIN rail connector.

We recommend connecting a 4 A fuse upstream.

Supply via a system power supply unit

The system power supply unit with 1.5 A output current connects the DIN rail connector to the supply voltage and can thus be used to supply several modules from the mains.

- MINI-SYS-PS-100-240AC/24DC/1.5 (Order No. 2866983)
- Potentially explosive areas:
MINI-PS-100-240AC/24DC/1.5/EX (Order No. 2866653)

6.5 Assembly

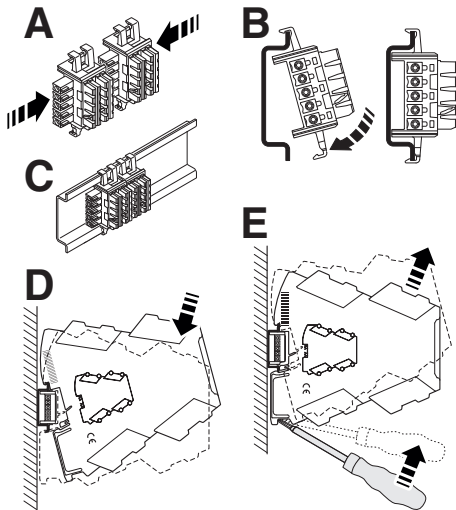

Figure 3 Mounting and removing

- Mount the module on a 35 mm DIN rail according to EN 60715.
- When using the DIN rail connector, first place it into the DIN rail (see A – C). It is used to bridge the power supply. It is also absolutely vital that you snap the module and the DIN rail connector into position in the correct direction: the snap-on foot should be at the bottom and the connector on the left.

6.6 FASTCON Pro plugs

The device has pluggable connection terminals with an integrated test disconnect terminal block, with either push-in or screw-in connection technology.

You can plug or screw the FASTCON Pro plugs onto the device directly without tools. You can use the integrated spindle screw to easily remove the plugs from the module or set the isolating position, even when the plugs are connected. For this purpose, use a screwdriver of sufficient width, e.g. SZF 1-0.6x3.5 (order number: 1204517).

4-way coding prevents incorrect insertion into the module.

Screw connection:

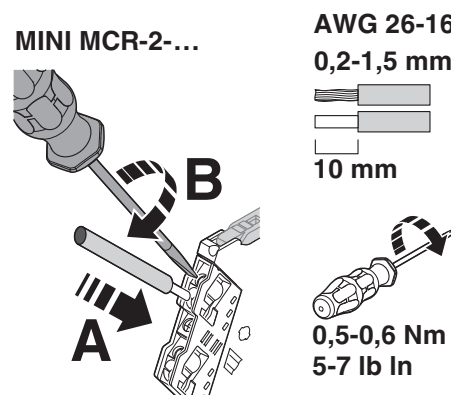

Figure 4 Screw connection

- Insert the wire into the corresponding connection terminal block.
- Use a screwdriver to tighten the screw in the opening above the connection terminal block.

Push-in connection:

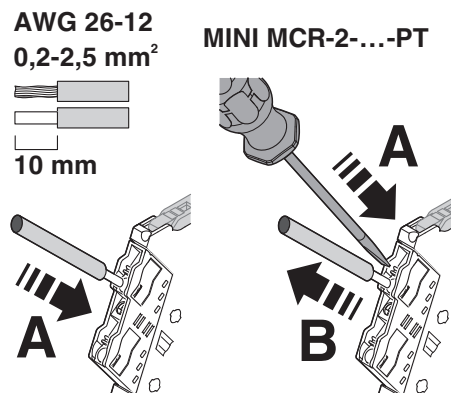

Figure 5 Push-in connection

- Insert the wire into the corresponding connection terminal block.

6.7 Fault monitoring FM

In addition to module and power supply failures, known faults in the signal input of the module are reported via the DIN rail connector to the form-matched MINI MCR-2-FM-RC (order number 2904504) or MINI MCR-2-FM-RC-PT (order number 2904508) fault monitoring module. The module reports the error centrally via an N/C contact.

A fault monitoring module is only required once in a group. There is no need for individual evaluation of up to 115 connected Mini Analog Pro signal conditioners.

For the behavior of the fault monitoring contact for the different DIP switch configurations, please refer to the corresponding table.

6.8 Current measurement

The device allows current measurement without disconnection of the conductors by means of integrated test disconnect terminals.

Test sockets which support current measurement are marked TI+ or TI-.

For the current measurement, use 2 mm probe tips of the type Fluke TL75-1 or probe tips with a comparable tip shape.

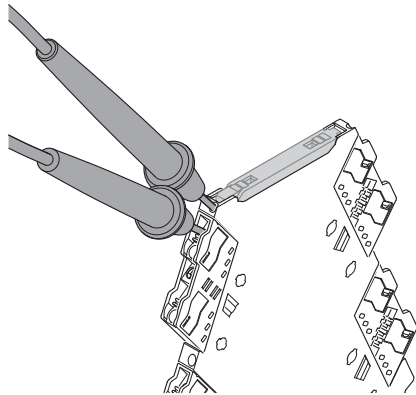

Figure 6 Test disconnect terminal block

Furthermore, individual circuits can be specifically disconnected, e.g. for commissioning.

You can set the isolating position by turning the integrated spindle screw through 180°. The isolating position is indicated by the marking on the plugs.

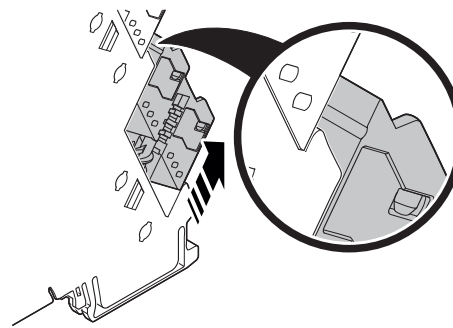

Figure 7 Disconnect position

6.9 Marking

Standard UCT-EM... or UC-EMLP tags are available for marking the devices and can be printed as per customer requirements. In addition, the covers provide enough space for the use of freely chosen sticky labels such as SK 5.0 WH:REEL without concealing the LED diagnostic indicators.

7 Configuration

The device is supplied with the following basic settings:

Type J IEC 584 TC sensor; cold junction compensation "ON"; -200...1200°C; output 4...20 mA; error evaluation according to NE43 (downscale); fault monitoring contact reacts upon any error.

Configuration is possible for all configuration variants without supply voltage.

7.1 Configuration via DIP switches

At delivery, all DIP switches are in the "OFF" position.

Configure the DIP switches according to the planned application using the configuration tables.

Configuration tables

		• ≙ ON DIP S1								
		1	2	3	4	5	6	7	8	
Sensor type	J (IEC 584)									
	K (IEC 584)	•								
Cold junction compensation	OFF									
	ON	•								
Analog output signal	0...20 mA									
	20...0 mA		•							
	4...20 mA				•					
	20...4 mA				•	•				
	0...10 V						•			
	10...0 V						•	•		
	0...5 V						•	•		
	1...5 V						•	•	•	
Start temperature	0°C ≙ 32°F									
	-10°C ≙ 14°F						•			
	-20°C ≙ -4°F							•		
	-30°C ≙ -22°F							•	•	
	-40°C ≙ -40°F								•	
	-50°C ≙ -58°F								•	•
	-100 °C ≙ -148°F								•	•
-150 °C ≙ -238°F								•	•	

Measuring range final value		DIP S2						• ≙ ON									
		1	2	3	4	5	6	1	2	3	4	5	6	7	8	9	0
0°C ≙ 32°F																	
10°C ≙ 50°F		•															
20°C ≙ 68°F			•														
30°C ≙ 86°F		•	•														
40°C ≙ 104°F				•													
50°C ≙ 122°F		•		•													
60°C ≙ 140°F			•	•													
70°C ≙ 158°F		•	•	•													
80°C ≙ 176°F					•												
90°C ≙ 194°F		•			•												
100°C ≙ 212°F			•		•												
110°C ≙ 230°F		•	•		•												
120°C ≙ 248°F				•	•												
130°C ≙ 266°F		•		•	•												
140°C ≙ 284°F			•	•	•												
150°C ≙ 302°F		•	•	•	•												
160°C ≙ 320°F						•											
170°C ≙ 338°F		•				•											
180°C ≙ 356°F			•			•											
190°C ≙ 374°F		•	•			•											
200°C ≙ 392°F				•	•												
210°C ≙ 410°F		•		•	•												
220°C ≙ 428°F			•	•	•												
230°C ≙ 446°F		•	•	•	•												
240°C ≙ 464°F					•	•											
250°C ≙ 482°F		•			•	•											
260°C ≙ 500°F			•		•	•											
270°C ≙ 518°F		•	•		•	•											
280°C ≙ 536°F				•	•	•											
290°C ≙ 554°F		•		•	•	•											
300°C ≙ 572°F			•	•	•	•											
320°C ≙ 608°F		•	•	•	•	•											
340°C ≙ 644°F													•				
360°C ≙ 680°F		•											•				
380°C ≙ 716°F			•										•				
400°C ≙ 752°F		•	•										•				
420°C ≙ 788°F				•									•				
440°C ≙ 824°F		•		•									•				
460°C ≙ 860°F			•	•									•				
480°C ≙ 896°F		•	•	•									•				
500°C ≙ 932°F					•								•				
520°C ≙ 968°F		•			•								•				
540°C ≙ 1004°F			•		•								•				
560°C ≙ 1040°F		•	•		•								•				
580°C ≙ 1076°F				•	•								•				
600°C ≙ 1112°F		•		•	•								•				
620°C ≙ 1148°F			•	•	•								•				
640°C ≙ 1184°F		•	•	•	•								•				
660°C ≙ 1220°F						•							•				
680°C ≙ 1256°F		•				•							•				
700°C ≙ 1292°F			•			•							•				
750°C ≙ 1382°F		•	•			•							•				
800°C ≙ 1472°F				•	•								•				
850°C ≙ 1562°F		•		•	•								•				
900°C ≙ 1652°F			•	•	•								•				
950°C ≙ 1742°F		•	•	•	•								•				
1000°C ≙ 1832°F					•	•							•				
1050°C ≙ 1922°F		•			•	•							•				
1100°C ≙ 2012°F			•		•	•							•				
1150°C ≙ 2102°F		•	•		•	•							•				
1200°C ≙ 2192°F				•	•	•							•				
1250°C ≙ 2282°F		•		•	•	•							•				
1300°C ≙ 2372°F			•	•	•	•							•				
1350°C ≙ 2462°F		•	•	•	•	•							•				

Error evaluation	Analog OUT								• \cong ON DIP S2			
	0...20 mA	20...0 mA	4...20 mA	20...4 mA	0...10 V	10...0 V	0...5 V	1...5 V	7	8	9	0
A Cable break	21 mA	21 mA	21 mA	21 mA	10.5 V	10.5 V	5.25 V	5.25 V				
Overrange	20.5 mA	20.5 mA	20.5 mA	20.5 mA	10.25 V	10.25 V	5.125 V	5.125 V				
Underrange	0 mA	0 mA	4 mA	4 mA	0 V	0 V	0 V	1 V				
B Cable break	21 mA	21 mA	21 mA	21 mA	10.5 V	10.5 V	5.25 V	5.25 V	•			
Overrange	20.5 mA	20.5 mA	20.5 mA	20.5 mA	10.25 V	10.25 V	5.125 V	5.125 V				
Underrange	0 mA	0 mA	3.5 mA	3.5 mA	0 V	0 V	0 V	0.875 V				
C Cable break	21 mA	21 mA	21 mA	21 mA	10.5 V	10.5 V	5.25 V	5.25 V		•		
Overrange	20 mA	20 mA	20 mA	20 mA	10 V	10 V	5 V	5 V				
Underrange	0 mA	0 mA	4 mA	4 mA	0 V	0 V	0 V	1 V				
D Cable break	0 mA	0 mA	4 mA	4 mA	0 V	0 V	0 V	1 V		•		
Overrange	20 mA	20 mA	20 mA	20 mA	10 V	10 V	5 V	5 V	•	•		
Underrange	0 mA	0 mA	4 mA	4 mA	0 V	0 V	0 V	1 V				
NE43 (only OUT = 4...20 mA or 20...4 mA)												
Upscale	Cable break, overrange, underrange							= 21.5 mA			•	
Downscale	Cable break, overrange, underrange							= 3.5 mA	•		•	
0 mA	Cable break, overrange, underrange							= 0 mA			•	•
Upscale/downscale	Cable break					= 3.5 mA			•		•	
	Overrange, underrange					= 21.5 mA			•		•	
Software/app configuration												
DIP switch configuration												

7.2 Configuration via software



Use the IFS-USB-PROG-ADAPTER programming adapter (Order No.: 2811271), the NFC-USB-PROG-ADAPTER (Order No.: 2900013), or the IFS-BT-PROG-ADAPTER (Order No.: 2905872) for connection of the device and PC.

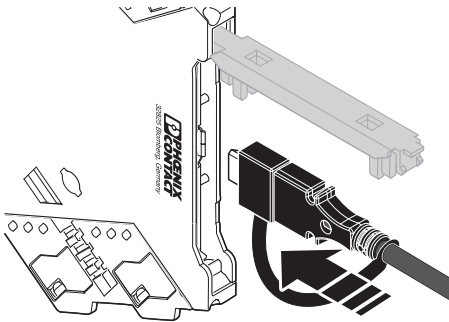

Figure 8 Programming connection

In addition to DIP switch settings, software configuration offers enhanced setting options and a monitoring function for maintenance purposes.

The following free software solutions are available for you to download from the Internet.

- ANALOG-CONF standard software
- FDT/DTM solutions: FDT frame application and DTM packages

7.3 Configuration via MINI Analog Pro app

In addition to DIP switch settings, app configuration offers enhanced setting options.

Using the MINI Analog Pro Smartphone app via the NFC interface of your Smartphone you can configure the module without an additional programming adapter or cables.

Alternatively, you can use the Bluetooth programming adapter (Order No. 2905872).

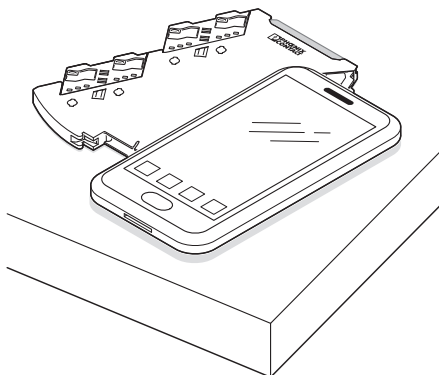

Figure 9 Configuration

8 Function description

8.1 Notes on using thermocouples

Thermocouples consist of two conductors made from different metals with different thermoelectric properties which are connected together on one side and are exposed to a temperature gradient and, therefore, convert heat flow to electrical voltage. Electrical voltage is measured at both thermocouple connections.

8.1.1 Cold junction compensation

In a thermocouple, however, voltage will not only be generated at the contact point of the connected conductors, but also at both connection points of the measuring transducer, as each of these points together with the connected thermocouple cable will form another thermocouple.

In order to be able to calculate the absolute measurement point temperature value from this voltage difference, and thus also the temperature difference, the temperature of the connection points must be the same and known.

To this end, the connection points are artificially maintained at a known temperature: for laboratory measurements, for example, at 0°C using ice water, in industrial applications with thermostatically controlled heating and cooling.

When considering the connection point temperature, this is referred to as cold junction compensation.

Cold junction compensation can also be implemented with a separate temperature measurement at the connection points.

Interface modules are available for the connection of thermocouples, in which cold junction compensation is already integrated. Interface modules of this type are also signal transformers with cable connections to the evaluation unit.

Thermocouples are often referred to with the abbreviation TC.



Thermocouples are suitable for high temperatures or large temperature ranges. Resistance thermometers are more suitable for temperatures up to a maximum of 800°C.

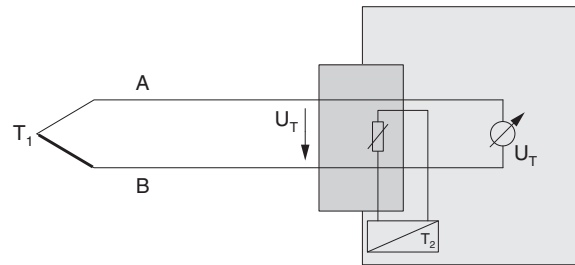

Figure 10 Thermocouple and interface module at the sensor including cold junction compensation

- T_1 Temperature at the measurement point
- T_2 Temperature at the connection point
- U_T Voltage generated between the measurement point and the connection point. Indicates the absolute temperature T_1 at the measurement point by considering the connection point temperature T_2 .

8.1.2 Thermocouple types

Type	Standard	Temperature range [°C]	IEC color code
B	IEC 584	+500 ... +1820	Not defined
E	IEC 584	-230 ... +1000	Purple
J	IEC 584	-210 ... +1200	Black
K	IEC 584	-250 ... +1372	Green
N	IEC 584	-200 ... +1300	Pink
R	IEC 584	-50 ... +1768	Orange
S	IEC 584	-50 ... +1768	Not defined
T	IEC 584	-200 ... +400	Brown
L	DIN 43710	-200 ... +900	-
U	DIN 43710	-200 ... +600	-
A-1	GOST 8.585	0 ... +2500	-
A-2	GOST 8.585	0 ... +1800	-
A-3	GOST 8.585	0 ... +1800	-
M	GOST 8.585	-200 ... +100	-
L	GOST 8.585	-200 ... +800	-

8.2 Analog switching output

If you configure the device using one of the software or app solutions, this additional function is available. It allows you to implement a threshold value switch without having to integrate an extra switching output or use a separate threshold value switch.

The analog output can be used as an analog switching output. A low level or high level is signaled at the analog output. The low level or high level can be freely adjusted within the analog output range of 0 mA ... 20 mA or 0 V ... 10 V. The minimum distance between the two levels must be 1 mA or 0.5 V. The high level must be greater than the low level.

Switching points

The switching points are set finitely and in the selected unit (°C/°F) and relate to the measuring input.

The two switching points can be configured within the input signal range as follows.

Sensor	Input range
Pt	-200 °C ... +850 °C
Ni	-60°C ... +250°C
Cu 50, Cu 100	-180°C ... +200°C
Cu 53	-50°C ... +180°C
Resistor	0 Ω ... 4000 Ω

Switching points must not exceed the maximum measuring range.

Switching behavior

Function of the switching output: signal high level after the switching point is exceeded; before this signal low level.

8.3 Monitoring

A monitoring function can be used with the software or app solutions. This means that you can display and note down current measured values via the software interface.

8.4 Limiting behavior of the analog output

In some applications it is important that the standard signal at the output remains within its limits. In the case of a 4 mA ... 20 mA signal, for example, this means that the signal does not drop below 4 mA or exceed 20 mA.

You can set this behavior under "Error signaling > Analog output > Limitation". The best way to do this is via the software or app solutions.

If you configure the device via the DIP switches, you must select the combination with which the error signaling outputs the measuring range starting value as the value for underrange and the measuring range final value as the value for overrange.

8.5 Diagnostic functions and error messages

Errors such as open circuit, short circuit, overrange, underrange, and module errors are detected by the modules. The errors are signaled via the analog output and/or the fault monitoring and/or, if present, via a switching output. At the same time, the error signaling is displayed by means of a red LED.

The respective error displays are removed when the error is eliminated.

The software and app solutions allow you to freely select and adjust all signaling variants.

If you configure the device via the DIP switches, you can choose between fixed signaling combinations (see configuration tables).

8.6 Simulation mode/force

During startup it must be possible to specify analog values without a pending sensor signal from the field.

The ANALOG-CONF and FDT/DTM software solutions allow you to simulate analog signals at the output.

You can set this behavior via "Service > Force analog output". It can be specified as a percentage in relation to the set input or as an absolute value of the output signal range.

9 Diagnostics and status indicators

Green LED	PWR	Supply voltage
	Lit	Supply voltage present
Red LED	ERR	Fault display or simulation mode
	Flashing fast (2.8 Hz)	Sensor fault or invalid DIP switch configuration
	Flashing slowly (1.4 Hz)	Simulation mode
	Lit	Internal device error