



Chipsmall Limited consists of a professional team with an average of over 10 year of expertise in the distribution of electronic components. Based in Hongkong, we have already established firm and mutual-benefit business relationships with customers from,Europe,America and south Asia,supplying obsolete and hard-to-find components to meet their specific needs.

With the principle of “Quality Parts,Customers Priority,Honest Operation,and Considerate Service”,our business mainly focus on the distribution of electronic components. Line cards we deal with include Microchip,ALPS,ROHM,Xilinx,Pulse,ON,Everlight and Freescale. Main products comprise IC,Modules,Potentiometer,IC Socket,Relay,Connector.Our parts cover such applications as commercial,industrial, and automotives areas.

We are looking forward to setting up business relationship with you and hope to provide you with the best service and solution. Let us make a better world for our industry!



Contact us

Tel: +86-755-8981 8866 Fax: +86-755-8427 6832

Email & Skype: info@chipsmall.com Web: www.chipsmall.com

Address: A1208, Overseas Decoration Building, #122 Zhenhua RD., Futian, Shenzhen, China



RAD-PT100-4-IFS

I/O extension module, 4 temperature inputs (Pt 100)



Data sheet
105366_en_00

© PHOENIX CONTACT 2013-12-06

1 Description

The **RAD-PT100-4-IFS** I/O extension module can be used in conjunction with Radioline wireless modules and other Interface system (IFS) master devices. In a station structure, you can connect up to 32 I/O extension modules to a wireless module via the DIN rail connector.

The **RAD-PT100-4-IFS** I/O extension module is used for processing four Pt 100 input signals.

Features

- Easy and tool-free I/O mapping via thumb wheel on the front
- Modular design via TBUS DIN rail connector (hot-swap capable)
- Channel-to-channel electrical isolation
- Four Pt 100 inputs (-50°C ... +250°C)
- International approvals
- Installation in Ex- Zone 2



WARNING: Explosion hazard when used in potentially explosive areas

The module is a category 3 item of electrical equipment. Follow the instructions provided here during installation and observe the safety instructions.



Make sure you always use the latest documentation.

It can be downloaded from the product at phoenixcontact.net/products.

Use the I/O extension module in connection with IFS master devices (e.g., Radioline wireless modules) with the latest firmware version. For the latest firmware version, please visit phoenixcontact.net/products.

This data sheet is valid for all products listed on the following page:

2	Table of contents	
1	Description	1
2	Table of contents	2
3	Ordering data	3
4	Technical data	3
5	Safety regulations and installation notes.....	6
	5.1 Installation and operation.....	6
	5.2 Safety regulations for installation in potentially explosive areas	7
6	Installation	8
	6.1 Structure	8
	6.2 Basic circuit diagram	8
	6.3 I/O MAP address in the Radioline wireless system	9
	6.4 Network applications (operating mode)	9
	6.5 Display and diagnostic elements	10
	6.6 Temperature input (Pt 100)	10
	6.7 Assembly/removal	11
	6.8 Connecting the cables	11
	6.9 Connecting the sensors.....	12
7	Process data.....	15
8	Error codes and formats for Pt 100 values.....	15

3 Ordering data

Description	Type	Order No.	Pcs. / Pkt.
Temperature I/O extension module with 4 PT 100 inputs (-50...+250 °C), with screw connection, including DIN rail connector	RAD-PT100-4-IFS	2904035	1
Accessories	Type	Order No.	Pcs. / Pkt.
2400 MHz wireless transceiver with RS-232, RS-485 2-wire interface, expandable with I/O extension modules, with screw connection, antenna connection: RSMA (female), including DIN rail connector, without antenna	RAD-2400-IFS	2901541	1
Bidirectional, Radioline 900 MHz transceiver for wireless transmission of serial and I/O data	RAD-900-IFS	2901540	1
DIN rail connector for DIN rail mounting. Universal for TBUS housing. Gold-plated contacts, 5-pos.	ME 17,5 TBUS 1,5/ 5-ST-3,81 GN	2709561	10
Analog I/O extension module with 4 analog current/voltage outputs (0/4 mA ... 20 mA, 0...10 V), with screw connection, incl. DIN rail connector	RAD-AO4-IFS	2901538	1

4 Technical data

Dimensions (nominal sizes in mm)

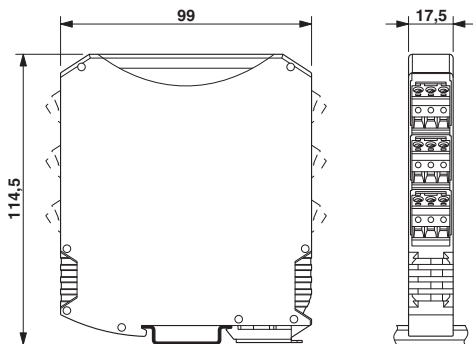

Dimensions W / H / D	17.5 mm / 99 mm / 114.5 mm
----------------------	----------------------------

General data	
Surge voltage category	II
Mounting position	any , on standard DIN rail NS 35 in accordance with EN 60715
Degree of protection	IP20
Pollution degree	2
Type of housing	PA 6.6-FR , green
MTTF (mean time to failure) Telcordia standard, 25°C temperature, 21% operating cycle (5 days a week, 8 hours a day)	1249 Years
MTTF (mean time to failure) Telcordia standard, 40°C temperature, 34.25% operating cycle (5 days a week, 12 hours a day)	506 Years
MTTF (mean time to failure) Telcordia standard, temperature 40°C, 100% operating cycle (7 days a week, 24 hours a day)	194 Years

Supply

Supply voltage range	19.2 V DC ... 30.5 V DC (TBUS)
Max. current consumption	≤ 38 mA (At 24 V DC, at 25°C)
Transient surge protection	Yes

Pt 100 input

Number of inputs	4
Sensor input current	1 mA (constant)
Temperature measuring range	-50 °C ... 250 °C
Measuring accuracy	0.1% (From the measuring range final value)
Connection method	2, 3-wire
Max. permissible overall conductor resistance	25 Ω
Process data channel	16 Bit (per channel)

Electrical isolation

Pt 100 inputs	50 V (Rated insulation voltage (in each case between the Pt 100 inputs / TBUS supply, reinforced insulation in accordance with EN 61010))
Neighboring devices	300 V (Rated insulation voltage (to adjacent devices, basic insulation in accordance with EN 61010))

Connection data

Connection method	Screw connection
Conductor cross section, solid	0.2 mm ² ... 2.5 mm ²
Conductor cross section, stranded	0.2 mm ² ... 2.5 mm ²
Conductor cross section AWG/kcmil	24 ... 14
Stripping length	7 mm
Tightening torque	0.6 Nm

Status indication

Status display	Green LED (supply voltage, PWR) Green LED (bus communication, DAT) Red LED (periphery error, ERR)
----------------	---

Ambient conditions

Ambient temperature (operation)	-40 °C ... 70 °C -40 °F ... 158 °F
Ambient temperature (storage/transport)	-40 °C ... 85 °C -40 °F ... 185 °F
Permissible humidity (operation)	20 % ... 85 %
Permissible humidity (storage/transport)	20 % ... 85 %
Altitude	2000 m
Vibration (operation)	In accordance with IEC 60068-2-6: 5 g, 10 Hz - 150 Hz
Shock	16 g, 11 ms

Certification

Conformance	CE-compliant
ATEX	⊕ II 3 G Ex nA IIC T4 Gc X
IECEX	Applied for
UL, USA / Canada	UL applied for

Conformance

EMC directive 2004/108/EC	EN 61000-6-2; EN 61000-6-4
Ex directive (ATEX)	EN 60079-0; EN 60079-15

Tolerances influenced by electromagnetic interference

Type of electromagnetic interference	Typical deviation of the measuring range final value (current input)	
	Relative	Absolute
-		
Electromagnetic fields according to EN 61000-4-3/IEC 61000-4-3	< ±0.35%	±0.6 °C
Conducted interference according to EN 61000-4-6/IEC 61000-4-6	< ±0.1%	±0.3 °C
Fast transients (burst) according to EN 61000-4-4/IEC 61000-4-4	< ±0.1%	±0.3 °C

5 Safety regulations and installation notes



WARNING: Risk of electric shock

- Provide a switch/circuit breaker close to the device, which is labeled as the disconnect device for this device or the entire control cabinet.
- Provide overcurrent protection ($I \leq 6 \text{ A}$) in the installation.
- Disconnect the device from all power sources during maintenance work and configuration (the device can remain connected to SELV or PELV circuits).
- The housing of the device provides a basic insulation against the neighboring devices, for 300 V eff. If several devices are installed next to each other, this has to be taken into account, and additional insulation has to be installed if necessary. If the neighboring device is equipped with basic insulation, no additional insulation is necessary.

5.1 Installation and operation



CAUTION:

Observe the following safety notes when using the device.

- The category 3 device is suitable for installation in potentially explosive area zone 2. It fulfills the requirements of EN 60079-0:2012 and EN 60079-15:2010.
- Installation, operation, and maintenance may only be carried out by qualified electricians. Follow the installation instructions as described. When installing and operating the device, the applicable regulations and safety directives (including national safety directives), as well as general technical regulations, must be observed. For the safety technology data, see this packing slip and the certificates (EC examination certificate and other approvals if appropriate).
- With the exception of configuration of the thumb wheel, opening or modifying the device is not permitted. Do not repair the device yourself; replace it with an equivalent device. Repairs may only be performed by the manufacturer. The manufacturer is not liable for harm resulting from noncompliance.
- The IP20 protection (IEC 60529/EN 60529) of the device is intended for use in a clean and dry environment. The device must not be subject to mechanical strain and/or thermal loads, which exceed the limits described.
- To protect the device against mechanical or electrical damage, install it in a suitable housing with appropriate degree of protection as per IEC 60529.
- The device is not designed for use in atmospheres with a danger of dust explosions.
- If dust is present, it is necessary to install into a suitable approved housing, whereby the surface temperature of the housing must be taken into consideration.

5.2 Safety regulations for installation in potentially explosive areas

**WARNING: Explosion hazard when used in potentially explosive areas**

Please make sure that the following notes and instructions are observed.

- Observe the specified conditions for use in potentially explosive areas! Install the device in a suitable approved housing with a minimum of IP54 protection) that meets the requirements of EN 60079-15. Observe the requirements of EN 60079-14.
- In zone 2, only connect devices to the supply and signal circuits that are suitable for operation in the Ex zone 2 and the conditions at the installation location.
- In potentially explosive areas, terminals may only be snapped onto or off the DIN rail connector and wires may only be connected or disconnected when the power is switched off.
- The switches of the device that can be accessed may only be actuated when the power supply to the device is disconnected.
- The device must be stopped and immediately removed from the Ex area if it is damaged, was subject to an impermissible load, stored incorrectly or if it malfunctions.

6 Installation



NOTE: electrostatic discharge!

The device contains components that can be damaged or destroyed by electrostatic discharge. When handling the device, observe the necessary safety precautions against electrostatic discharge (ESD) according to EN 61340-5-1 and IEC 61340-5-1.

6.1 Structure

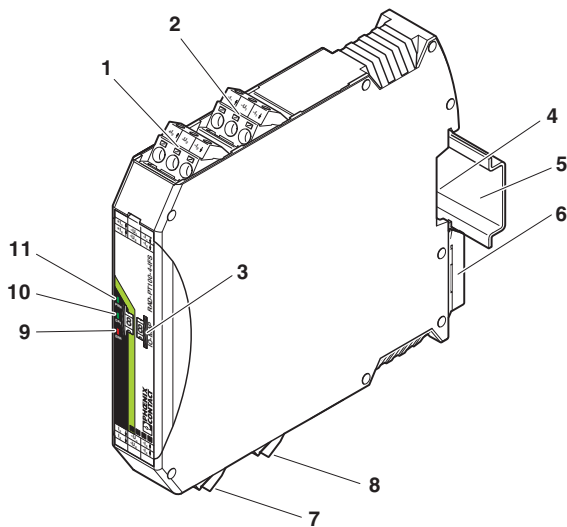

Figure 1 RAD-PT100-4-IFS

Pos.	Designation
1	Pt 100 input 2 for 2- and 3-wire sensors
2	Pt 100 input 1 for 2- and 3-wire sensors
3	White thumbwheel for setting the I/O-MAP address
4	Connection option for TBUS DIN rail connector
5	DIN rail
6	Metal foot catch for DIN rail fixing
7	Pt 100 input 3 for 2- and 3-wire sensors
8	Pt 100 input 4 for 2- and 3-wire sensors
9	ERR status LED, red (communication error)
10	DAT status LED, green (BUS communication)
11	PWR status LED, green (supply voltage)

6.2 Basic circuit diagram

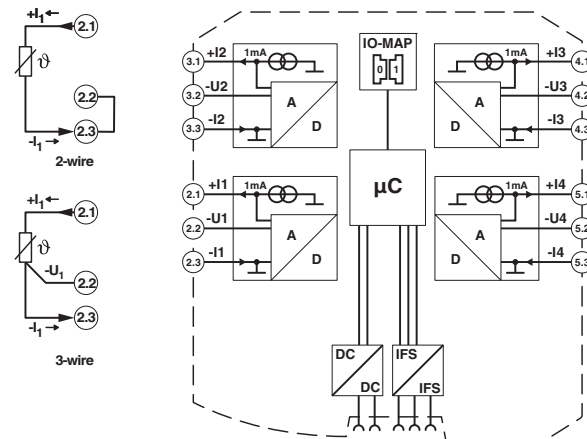

Figure 2 RAD-PT100-4-IFS basic circuit diagram

6.3 I/O MAP address in the Radioline wireless system

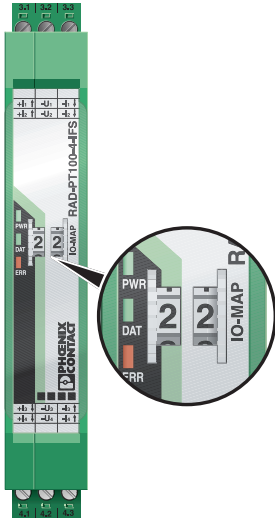

Figure 3 Thumb wheel

Use the thumbwheel to set the I/O-MAP address. The extension module in the Radioline wireless system is addressed using the I/O-MAP address.

On the entire wireless network, addresses 1 to 99 (I/O MAP) (maximum) may be assigned for the I/O extension modules.



The I/O MAP address of an input module may only appear once in the network.

Thumb wheel settings	Description
01 - 99	I/O MAP address
00	Delivery state
** , 1* - 9*	Setting not permitted
*1 - *9	Interface System slave address, for use with other Interface System (IFS) master devices

6.4 Network applications (operating mode)

You can set the network application of the wireless module with the PSI-CONF software. All RAD-2400-IFS Radioline wireless modules are set to I/O data mode (wire in/wire out) by default.

Radioline wireless module in I/O data mode

The input device must be provided with the same I/O MAP address as the assigned output device at the other Radioline wireless station (I/O mapping).

Example:	I/O MAP address
RAD-PT100-4-IFS	02
RAD-AO4-IFS	02

Only the RAD-AO4-IFS module can be assigned to the RAD-PT100-4-IFS module.

The Pt 100 inputs, T1 ... T4, can be configured to the analog outputs I1/U1 ... I4/U4 of the RAD-AO4-IFS extension module.

Pt 100 input	Analog output
-50°C	0 mA or 0 V
+250°C	20 mA or 10 V

Radioline wireless module in PLC/Modbus RTU mode

The I/O MAP address of an input module may only appear once in the network.

The input data is saved in a Modbus memory map in the Radioline master wireless module.

You can read or write the process data via the serial interface of the RAD-2400-IFS master wireless module (RAD-ID = 01) using the Modbus RTU command (see Section 7).

6.5 Display and diagnostic elements

The I/O extension module uses a total of three LEDs to indicate the operating states.



Figure 4 Display and diagnostic elements

PWR LED

The green PWR LED indicates the supply voltage status.

- OFF No supply voltage
- ON Supply voltage OK

DAT LED

The green DAT LED indicates the bus communication status.

- OFF No communication
- Flashing Configuration/addressing mode
- ON Cyclic data communication

ERR LED

The red ERR LED indicates the error status, e.g., no corresponding output module found (e.g., incorrect addressing).

- OFF No error
- Flashing Slow (1.4 Hz) I/O-MAP address changed
- Fast (2.8 Hz) No bus communication
- ON Critical internal error

6.6 Temperature input (Pt 100)

The Pt 100 inputs of the extension module can process temperatures from -50 °C ... +250 °C.

All the inputs are electrically isolated from one another, from the supply voltage (via bus foot), and from other electronic components.

Pt 100 resistance thermometers can be connected to the RAD-PT100-4-IFS I/O extension module. The thermometers change their resistance depending on the temperature. The Pt 100 input signals are acquired by the RAD-PT100-4-IFS and can be mapped to proportional, analog voltage or current signals of the RAD-AO4-IFS output module. Thus, conclusions can be made about the temperature via the standard analog signal.

$$1\text{ °C} \cong 66.66\ \mu\text{A}$$

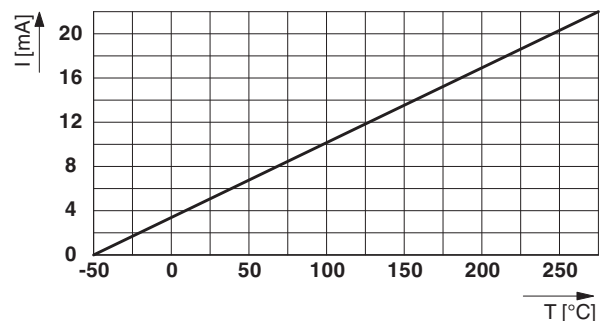

Figure 5 Current strength [mA] depending on the temperature [°C]

6.7 Assembly/removal

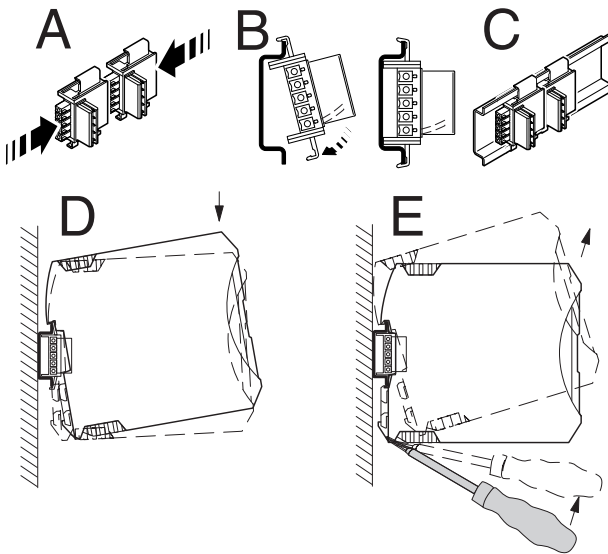

Figure 6 Mounting and removing

When using the device in a connection station, use the 17.5 mm wide DIN rail connector supplied. Only use the DIN rail connector in connection with 24 V DC devices.



Outside the Ex area, module extension or module replacement is also possible during operation.

- Connect the DIN rail connectors together for a connection station.
- Push the connected DIN rail connectors into the DIN rail.
- Place the device onto the DIN rail from above. Ensure the device and DIN rail connector are aligned correctly.
- Holding the device by the housing cover, carefully push the device towards the mounting surface so that the device bus connector is securely fixed onto the DIN rail connector.
- Once the snap-on foot has been audibly snapped onto the DIN rail, check that it is fixed securely. The device is only mechanically secured via the DIN rail.
- Connect the desired number of I/O extension modules to the wireless module via the DIN rail connector.
- Install the device in suitable housing to meet the requirements for the protection class.
- During startup, check that the device is operating, wired, and marked correctly.

- You can establish a connection between two DIN rail connectors using MINI COMBICON connectors: MC 1,5/5-ST-3,81 (female, 1803604); IMC 1,5/5-ST-3,81 (male, 1857919).

6.8 Connecting the cables

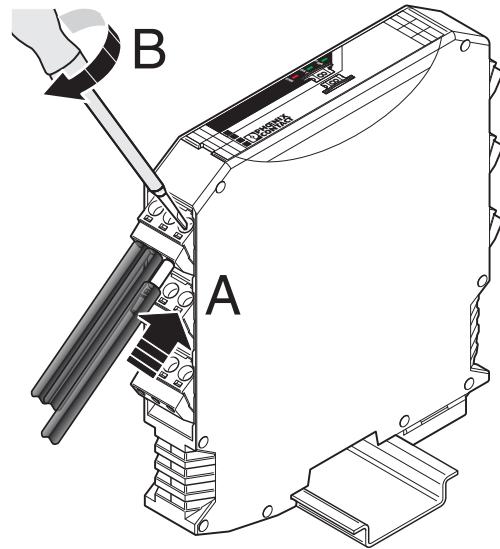

Figure 7 Connecting the cables

- Crimp ferrules to the wires. Permissible cable cross section: 0.2...2.5 mm².
- Insert the wire with ferrule into the corresponding connection terminal block.
- Use a screwdriver to tighten the screw in the opening above the connection terminal block. Tightening torque: 0.6 Nm

6.9 Connecting the sensors

You can connect 2-wire or 3-wire sensors to the extension module. Take into account the measuring errors depending on the different measuring methods.

2-wire connection method

With 2-wire technology, you need an insertion bridge between terminals x.2 and x.3.

For short distances (< 10 m).

- Connect the Pt 100 sensor to terminals x.1 and x.3.
- Bridge the terminals x.2 and x.3.

2-wire connection technology is the most cost-effective connection method. The temperature-related voltage is not directly measured at the sensor and is therefore falsified by the two cable resistances. The measuring errors that occur may render the entire measurement useless.



Cable resistances R_{L1} and R_{L2} are incorporated in the measurement result directly and falsify the result accordingly.

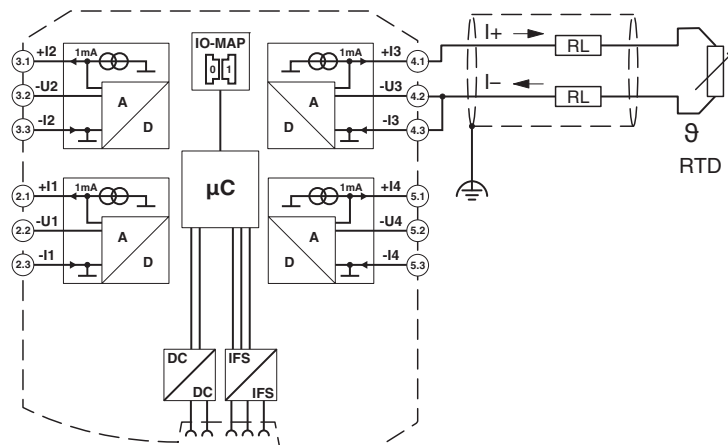

Figure 8 2-wire connection technology

3-wire connection method

For long distances between the Pt 100 sensor and the extension module. To compensate the wire resistances, all wire resistances must have exactly the same values ($R_{L1} = R_{L2} = R_{L3}$).

- Connect the Pt 100 sensor to terminals x.1, x.2, and x.3.

With 3-wire connection technology, the temperature-related voltage is measured several times. Corresponding calculations additionally reduce the effect of the cable resistance on the measurement result. The results are almost as good as those achieved using 4-wire technology.

The cable resistances R_L at terminals +I and -I must have the same value. This allows you to subtract the established cable resistance from the measurement result and to get the Pt 100 platinum resistance value.

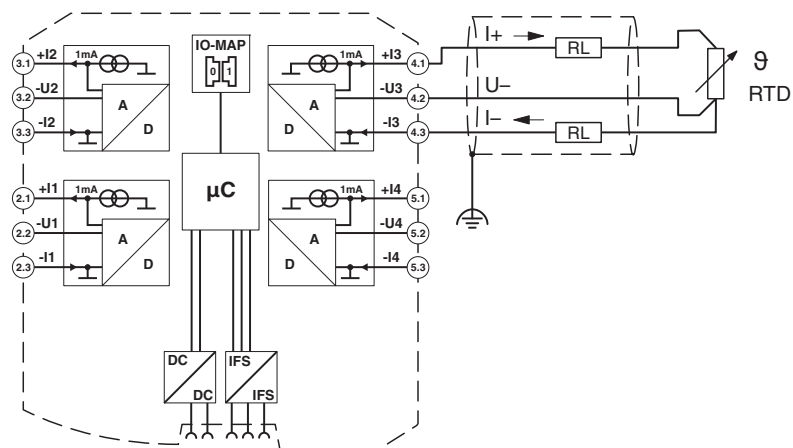

Figure 9 3-wire connection method

4-wire connection method

The extension module does not support 4-wire connection technology.

- If you want to use a 4-wire sensor, only connect three of the four wires.
- The fourth wire should be left unwired. Otherwise there will be a different resistance in the +I and -I cables owing to the parallel connection of two cable resistances.

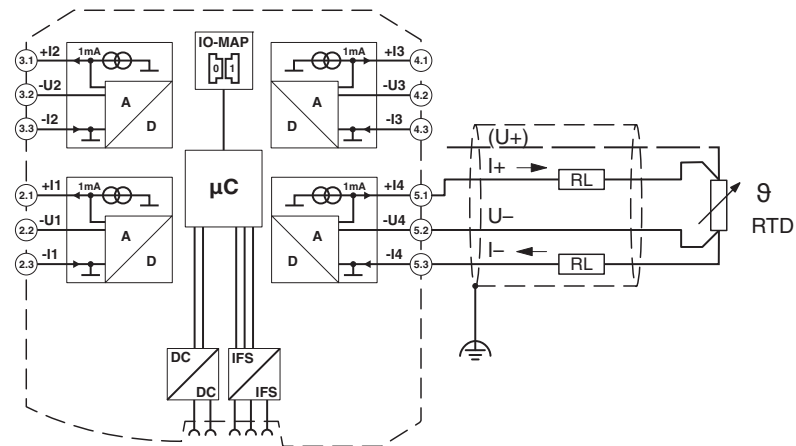

Figure 10 4-wire connection technology

7 Process data

With the PSI-CONF software, you can set the wireless module's network application to "PLC/Modbus RTU mode".

You can read the process data via the serial interface of the RAD-2400-IFS master wireless module (RAD-ID = 01) using the Modbus RTU command.

I/O module	Module type	Number of registers	Address space	Function code
RAD-PT100-4-IFS	21 _{hex}	06 _{hex}	30xx0 ... 30xx5	fc04

30xx0		Module type and currentness of data														
15	14	13	12	11	10	09	08	07	06	05	04	03	02	01	00	
							X	Module type								

xx = I/O-MAP address set using the thumbwheel

X = Currentness of data, bit 8

Register values:

Module type If the module type in the register is invalid or unavailable, then the register value is 0

Currentness of data If the data in the register is not up-to-date, then the register value is 1.

This is the case, for example, if the wireless connection or communication with an input module fails.

The IN process data is retained in the Modbus table, but is no longer updated.

The read I/O data is only valid and current if a valid module type value is returned by the slave and the "Currentness of data" register value equals 0.

30xx1	Reserved
-------	----------

30xx2		Pt 100 input 1, terminal point 2.x													
15	14	13	12	11	10	09	08	07	06	05	04	03	02	01	00
T1															

30xx3		Pt 100 input 2, terminal point 3.x													
15	14	13	12	11	10	09	08	07	06	05	04	03	02	01	00
T2															

30xx4		Pt 100 input 3, terminal point 4.x													
15	14	13	12	11	10	09	08	07	06	05	04	03	02	01	00
T3															

30xx5		Pt 100 input 4, terminal point 5.x													
15	14	13	12	11	10	09	08	07	06	05	04	03	02	01	00
T4															

30xx6 ... 30xx9	Reserved
-----------------	----------

8 Error codes and formats for Pt 100 values

Data word		Pt 100 input	RAD-AO4-IFS, analog output		Possible cause
hex	dec/error code	-50 °C ... +250 °C	0 mA ... 20 mA	0 V ... 10 V	
0000	0	-50°C	0 mA	0 V	
7530	30000	+250°C	20 mA	10 V	
7F00	32512	+275.12 °C	21.67 mA	10.84 V	
8001	Overrange				
8002	Open circuit				Sensor wired incorrectly, measuring line too long, cable resistance too high
8080	Underrange				