



Chipsmall Limited consists of a professional team with an average of over 10 year of expertise in the distribution of electronic components. Based in Hongkong, we have already established firm and mutual-benefit business relationships with customers from,Europe,America and south Asia,supplying obsolete and hard-to-find components to meet their specific needs.

With the principle of “Quality Parts,Customers Priority,Honest Operation,and Considerate Service”,our business mainly focus on the distribution of electronic components. Line cards we deal with include Microchip,ALPS,ROHM,Xilinx,Pulse,ON,Everlight and Freescale. Main products comprise IC,Modules,Potentiometer,IC Socket,Relay,Connector.Our parts cover such applications as commercial,industrial, and automotives areas.

We are looking forward to setting up business relationship with you and hope to provide you with the best service and solution. Let us make a better world for our industry!



Contact us

Tel: +86-755-8981 8866 Fax: +86-755-8427 6832

Email & Skype: info@chipsmall.com Web: www.chipsmall.com

Address: A1208, Overseas Decoration Building, #122 Zhenhua RD., Futian, Shenzhen, China



Current transformer - PACT RCP-4000A-UIRO-D140 - 2906232

Please be informed that the data shown in this PDF Document is generated from our Online Catalog. Please find the complete data in the user's documentation. Our General Terms of Use for Downloads are valid (<http://phoenixcontact.com/download>)



Set consisting of a 4-way signal conditioner with screw connection technology and a Rogowski coil 450 mm in length/140 mm in diameter for AC current measurement on busbars and power lines. The signal conditioner outputs 8 different standard signals on the output side and has one switching output.

RoHS

Key Commercial Data

Packing unit	1 STK
GTIN	 4 055626 048291
GTIN	4055626048291

Technical data

Measuring transducer supply

Nominal supply voltage	24 V DC
Nominal supply voltage range	9.6 V DC ... 30 V DC
Power consumption	≤ 1 W (at I _{OUT} = 20 mA, 9.6 V DC, 600 Ω load)

Measuring coil input data

Frequency measuring range	40 Hz ... 20000 Hz
Position error	< 1 %
Linearity error	0.1 %

Measuring transducer input data

Measuring ranges (current)	100 A 250 A 400 A 630 A 1000 A 1500 A 2000 A 4000 A
Configurable/programmable	Via DIP switches

Measuring transducer signal input

Input signal (at 50 Hz)	100 mV (1000 A)
Input impedance	> 100 kΩ

Measuring coil signal output

Output signal (at 50 Hz)	100 mV (no load, at 1,000 A)
Output voltage (in no-load operation)	V _{OUT} = M * di/dt

Current transformer - PACT RCP-4000A-UIRO-D140 - 2906232

Technical data

Measuring coil signal output

Output voltage (sinusoidal, in no-load operation)	100 mV ($V_{OUT} = 2 * \pi * M * f * I$ (M = 0.318 μ H; example: At 50 Hz; I = 1,000 A))
---	---

Measuring transducer signal output

Current output signal	0 mA ... 20 mA (via DIP switch)
	4 mA ... 20 mA (via DIP switch)
	0 mA ... 10 mA (via DIP switch)
	2 mA ... 10 mA (via DIP switch)
	0 mA ... 21 mA (can be set via software)
Voltage output signal	0 V ... 10 V (via DIP switch)
	2 V ... 10 V (via DIP switch)
	0 V ... 5 V (via DIP switch)
	1 V ... 5 V (via DIP switch)
	0 V ... 10.5 V (can be set via software)
Load/output load current output	$\leq 600 \Omega$ (20 mA)

General data, measuring coil

Length of measuring coil	450 mm
Diameter of measuring coil	8.3 mm ± 0.2 mm
Length of signal cable	3000 mm
Conductor structure signal line	2x 0.22 mm (Signal (tinned))
	1x 0.22 mm (Shielding (tinned))
Coil material	Elastollan
Housing material	PC
Insulation	double insulation
Rated insulation voltage	1000 V AC (rms CAT III)
	600 V AC (rms CAT IV)
Test voltage	10.45 kV (DC / 1 min.)
Basic accuracy	$\leq \pm 0.21$ %
UL, USA/Canada	UL 61010 Recognized

General data for measuring transducer

Maximum transmission error	≤ 0.5 % (From the range end value)
Frequency range	16 Hz ... 1000 Hz
Housing material	PBT
Test voltage	3 kV (50 Hz, 1 min.)
UL, USA/Canada	UL 508 Listed

General data

Standards/regulations	IEC 61010-1
	IEC 61010-2-032
Degree of pollution	2
Overvoltage category	II

Current transformer - PACT RCP-4000A-UIRO-D140 - 2906232

Technical data

General data

Typical measuring error	< 1 %
-------------------------	-------

Connection data

Connection name	Measuring transducer side
Conductor cross section flexible min.	0.2 mm ²
Conductor cross section flexible max.	1.5 mm ²
Conductor cross section solid min.	0.2 mm ²
Conductor cross section solid max.	1.5 mm ²
Conductor cross section AWG min.	26
Conductor cross section AWG max.	16
Screw thread	M3
Connection method	Screw connection
Stripping length	10 mm
Torque	0.5 Nm ... 0.6 Nm

Dimensions

Width	6.20 mm
Height	110.50 mm
Depth	120.50 mm

Ambient conditions

Ambient temperature (operation)	-30 °C ... 80 °C (Measuring coil)
	-40 °C ... 70 °C (Measuring transducer)
Ambient temperature (storage/transport)	-40 °C ... 80 °C (Measuring coil)
	-40 °C ... 85 °C (Measuring transducer)
Maximum altitude	> 4000 m
Measuring coil degree of protection	IP67 (not assessed by UL)
Measuring transducer degree of protection	IP20

Standards and Regulations

Electromagnetic compatibility	Conformance with EMC Directive 2004/108/EC
Noise emission	EN 61000-6-4
Standards/regulations	IEC 61010-1
	IEC 61010-2-032
Rated insulation voltage	300 V
Degree of pollution	2
Overvoltage category	II
Electrical isolation	Reinforced insulation in accordance with IEC 61010-1
Conformance	CE-compliant

Environmental Product Compliance

China RoHS	Environmentally Friendly Use Period = 50
------------	--

Current transformer - PACT RCP-4000A-UIRO-D140 - 2906232

Technical data

Environmental Product Compliance

	For details about hazardous substances go to tab "Downloads", Category "Manufacturer's declaration"
--	---

Drawings

Block diagram

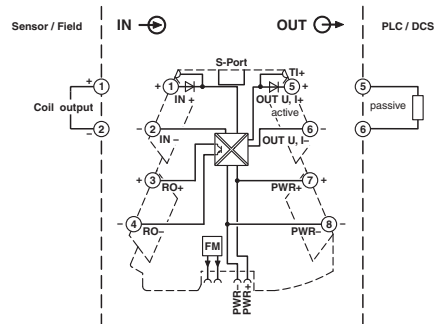

Approvals

Approvals

Approvals

EAC

Ex Approvals

Approval details

EAC		RU C- DE.A*30.B.01082
-----	--	--------------------------

Phoenix Contact 2018 © - all rights reserved
<http://www.phoenixcontact.com>

PHOENIX CONTACT GmbH & Co. KG
Flachsmarktstr. 8
32825 Blomberg
Germany
Tel. +49 5235 300
Fax +49 5235 3 41200
<http://www.phoenixcontact.com>