



Chipsmall Limited consists of a professional team with an average of over 10 year of expertise in the distribution of electronic components. Based in Hongkong, we have already established firm and mutual-benefit business relationships with customers from,Europe,America and south Asia,supplying obsolete and hard-to-find components to meet their specific needs.

With the principle of "Quality Parts,Customers Priority,Honest Operation,and Considerate Service",our business mainly focus on the distribution of electronic components. Line cards we deal with include Microchip,ALPS,ROHM,Xilinx,Pulse,ON,Everlight and Freescale. Main products comprise IC,Modules,Potentiometer,IC Socket,Relay,Connector.Our parts cover such applications as commercial,industrial, and automotives areas.

We are looking forward to setting up business relationship with you and hope to provide you with the best service and solution. Let us make a better world for our industry!



Contact us

Tel: +86-755-8981 8866 Fax: +86-755-8427 6832

Email & Skype: info@chipsmall.com Web: www.chipsmall.com

Address: A1208, Overseas Decoration Building, #122 Zhenhua RD., Futian, Shenzhen, China



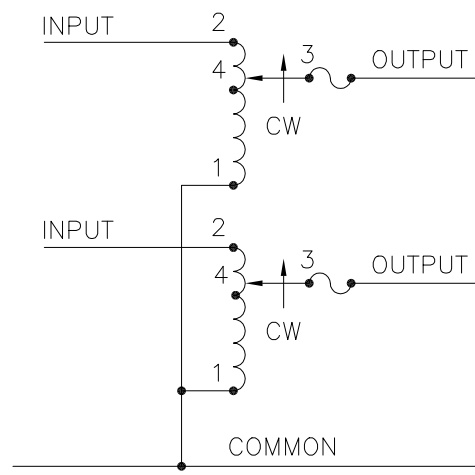
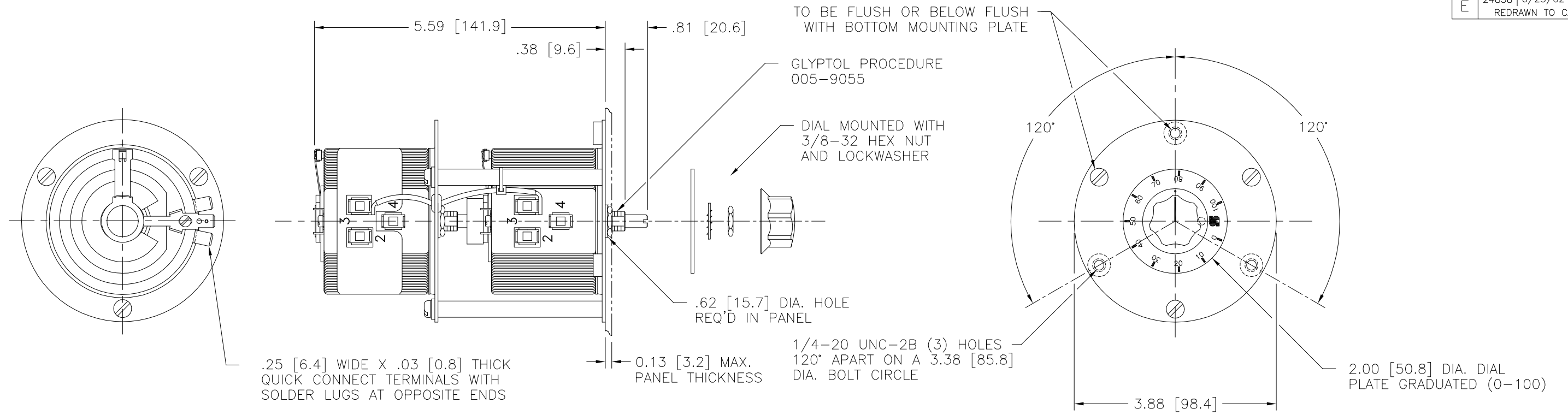

SCHMATIC
FUSE RECOMMENDED BUT NOT SUPPLIED

++ LINE TO LINE VOLTAGE

⌈ IF GANGED UNITS ARE USED IN A SYSTEM THAT ORDINARILY HAS A COMMON NEUTRAL OR GROUND BETWEEN SOURCE AND LOAD, THE NEUTRAL OR GROUND MUST BE CONNECTED TO THE COMMON TERMINALS OF THE VARIABLE TRANSFORMER ASSEMBLY. IF THE SYSTEM HAS NO NEUTRAL, THE LOAD MUST BE BALANCED OR THE TRANSFORMERS WILL BE DAMAGED.

■ JUMPER PROVIDED IN THE STANDARD COMMON POSITION AND SHOULD BE MOVED OR REMOVED AS REQUIRED.

SPECIFICATIONS											
WIRING	INPUT		OUTPUT				SHAFT ROTATION TO INCREASE VOLTAGE	TERMINAL CONNECTIONS			
	VOLTS	HERTZ	VOLTS	CONSTANT CURRENT LOAD		CONSTANT IMPEDANCE LOAD		FOR INCREASING VOLTAGE AS VIEWED FROM BASE END			
				MAX. AMPS	MAX. KVA	MAX. AMPS		MAX. KVA	INPUT	JUMPER	OUTPUT
SINGLE PHASE SERIES	240	50/60	0-240	3.0	0.72	3.5	0.84	CW	2-2	1-1	3-3
		60	0-264	3.0	0.79	-	-	CCW	1-1	2-2	3-3
THREE PHASE OPEN DELTA ⌈	120	50/60	0-120	3.0	0.62	3.5	0.73	CW	2-1-2	1-1	3-1-3
		60	0-132	3.0	0.69	-	-	CCW	1-2-1	2-2	3-2-3
			++						CW	4-1-4	1-1

UNLESS OTHERWISE SPECIFIED, TOLERANCE IS ±

DECIMALS	HOLES	ANGLES	DRAFT	UNITS
.XX	.0005	1°	1-1/2°	IN [mm]
.XXX	.005			

MATERIAL: ALL DIMENSIONS APPLY AFTER PLATING

TITLE: SPEC. CONTROL DRAWING VARIABLE TRANSFORMER TYPE: 291-2

STACO ENERGY PRODUCTS CO. A Components Corporation of America Company 302 Gadsden Boulevard Dayton, Ohio 45403 USA

DRAWN BY	DATE	FIRST USED ON	DO NOT SCALE DWG.
TIM RAU	6/6/02		
CHECKER	DATE	WEIGHT APPROX.	CAGE CODE
		5.50 LBS.	83008
ENGINEER	DATE	SCALE	DWG. NO.
		1=1	031-0292

SHEET 1 OF 1