



Chipsmall Limited consists of a professional team with an average of over 10 year of expertise in the distribution of electronic components. Based in Hongkong, we have already established firm and mutual-benefit business relationships with customers from,Europe,America and south Asia,supplying obsolete and hard-to-find components to meet their specific needs.

With the principle of “Quality Parts,Customers Priority,Honest Operation,and Considerate Service”,our business mainly focus on the distribution of electronic components. Line cards we deal with include Microchip,ALPS,ROHM,Xilinx,Pulse,ON,Everlight and Freescale. Main products comprise IC,Modules,Potentiometer,IC Socket,Relay,Connector.Our parts cover such applications as commercial,industrial, and automotives areas.

We are looking forward to setting up business relationship with you and hope to provide you with the best service and solution. Let us make a better world for our industry!



Contact us

Tel: +86-755-8981 8866 Fax: +86-755-8427 6832

Email & Skype: info@chipsmall.com Web: www.chipsmall.com

Address: A1208, Overseas Decoration Building, #122 Zhenhua RD., Futian, Shenzhen, China



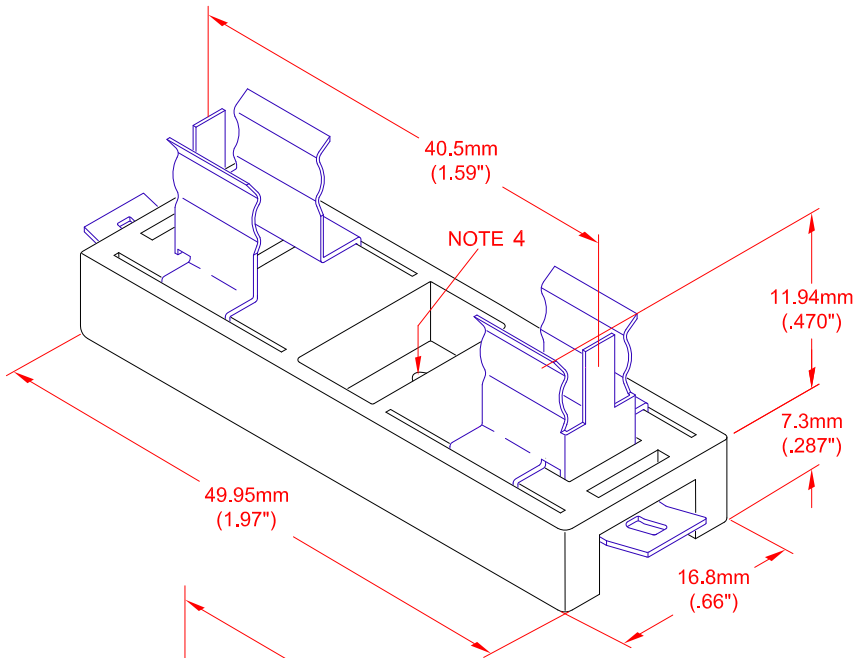

JKL PART NO.: 2910F-42

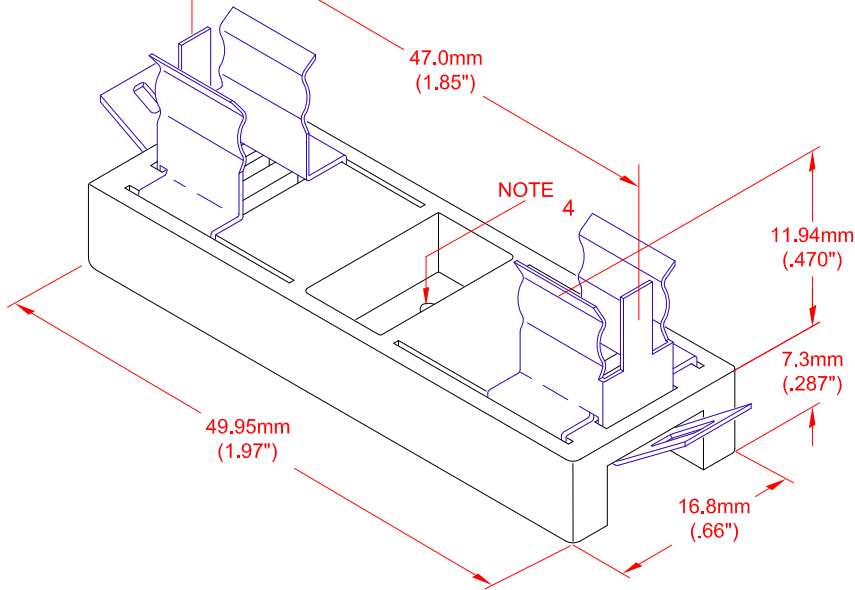

JKL PART NO.: 2910F-47

NOTES:

1. TAB SIZE REFERENCE DIMENSIONS: .244" wide X .30" deep X .016 thick.
KEYSTONE P/N 4470 QUICK-FIT SOCKET MAY BE USED FOR CONTACT.
2. LAMP SIZES FOR EACH HOLDER:
-42 HOLDER CAN HOLD LAMPS FROM 38mm TO 43mm LONG
-47 HOLDER CAN HOLD LAMPS FROM 40mm TO 44mm LONG
3. MINIMUM CONTACT DIAMETER .30"
4. LOCATION OF MOUNTING HOLE. HOLE DIA. : Ø3.5mm REF.
5. BODY MATERIAL: DUPONT FR50
MAX. WITHSTAND TEMPERATURE 130C
MAX. INTERMITTENT TEMPERATURE 180C
MAX. WATTAGE: -42 10W
 -47 18W

<table border="1"> <tr> <td>F</td> <td>CHANGE NOTE 2 HOLDER SIZES</td> <td>8/23/12</td> </tr> <tr> <td>E</td> <td>CHANGE NOTE 2</td> <td>3/9/10</td> </tr> <tr> <td>D</td> <td>ADDED NOTES</td> <td>8/7/08</td> </tr> <tr> <td>C</td> <td>CORR. MATERIAL DESCRIPTION</td> <td>11/13/07</td> </tr> <tr> <td>B</td> <td>ADD NOTES</td> <td>8/18/06</td> </tr> <tr> <td>A</td> <td>ADD PART NO. 2910F-47</td> <td>6/30/06</td> </tr> <tr> <td></td> <td>RELEASED</td> <td>6/12/06</td> </tr> </table>			F	CHANGE NOTE 2 HOLDER SIZES	8/23/12	E	CHANGE NOTE 2	3/9/10	D	ADDED NOTES	8/7/08	C	CORR. MATERIAL DESCRIPTION	11/13/07	B	ADD NOTES	8/18/06	A	ADD PART NO. 2910F-47	6/30/06		RELEASED	6/12/06	<p>METRIC</p> <p>THIRD ANGLE PROJECTION</p>		<p>DIMENSIONS ARE IN MILLIMETERS</p> <p>TOLERANCE UNLESS OTHERWISE SPECIFIED</p> <p>1 PL +/- REF.</p> <p>2 PL +/- REF.</p> <p>ANGLE +/- 0</p>		<p>JKL COMPONENTS CORPORATION</p>			
F	CHANGE NOTE 2 HOLDER SIZES	8/23/12																													
E	CHANGE NOTE 2	3/9/10																													
D	ADDED NOTES	8/7/08																													
C	CORR. MATERIAL DESCRIPTION	11/13/07																													
B	ADD NOTES	8/18/06																													
A	ADD PART NO. 2910F-47	6/30/06																													
	RELEASED	6/12/06																													
					<p>TITLE</p> <p style="text-align: center;">FESTOON HOLDER</p>																										
			<p>DRAWN BY</p> <p>L. WENGSTROM</p>		<p>APPVD BY</p> <p>L. R.</p>		<p>DATE</p> <p>8/23/12</p>		<p>SIZE</p> <p>A</p>		<p>FSCM NO.</p> <p>55335</p>		<p>DRAWING NO.</p> <p>2910F</p>																		
<p>REV. NO.</p>			<p>DESCRIPTION/ECO NUMBER</p>			<p>APPVD DATE</p>		<p>- CAD DRAWING -</p> <p>MANUAL REVISIONS NOT PERMITTED</p>		<p>SCALE</p> <p>NONE</p>		<p>RELEASED DATE</p> <p>6/12/06</p>		<p>REVISION DATE</p> <p>8/23/12</p>		<p>REV. NO.</p> <p>F</p>		<p>SHEET</p> <p>1 OF 1</p>													