



Chipsmall Limited consists of a professional team with an average of over 10 year of expertise in the distribution of electronic components. Based in Hongkong, we have already established firm and mutual-benefit business relationships with customers from,Europe,America and south Asia,supplying obsolete and hard-to-find components to meet their specific needs.

With the principle of “Quality Parts,Customers Priority,Honest Operation,and Considerate Service”,our business mainly focus on the distribution of electronic components. Line cards we deal with include Microchip,ALPS,ROHM,Xilinx,Pulse,ON,Everlight and Freescale. Main products comprise IC,Modules,Potentiometer,IC Socket,Relay,Connector.Our parts cover such applications as commercial,industrial, and automotives areas.

We are looking forward to setting up business relationship with you and hope to provide you with the best service and solution. Let us make a better world for our industry!



Contact us

Tel: +86-755-8981 8866 Fax: +86-755-8427 6832

Email & Skype: info@chipsmall.com Web: www.chipsmall.com

Address: A1208, Overseas Decoration Building, #122 Zhenhua RD., Futian, Shenzhen, China



Altimeter Module MS5607 (#29124)

The Altimeter Module is a high-resolution (20 cm) altimeter sensor, with SPI and I²C bus interface. The module includes a pressure sensor and a temperature output, allowing implementation of an altimeter/thermometer/barometer without any additional sensors. It provides a precise digital 24-bit pressure and temperature value.

Features

- High resolution: 20 cm
- Thermometer range: -40 to +85 °C, with <.01 °C resolution
- Pressure range: 10 to 1200 mbar
- Supports I²C and SPI communications
- 24-bit pressure and temperature values



Key Specifications

- Power requirements: 3.3 to 6.5 VDC
- Communication interface: I²C (up to 400 kHz) or SPI (20 MHz)
- Operating temperature: -40 to +185 °F (-40 to +85 °C)
- Dimensions: 0.85 X 0.80 in (2.16 X 2.03 cm)

Application Ideas

- Mobile altimeter / barometer systems
- Rate of climb and descent indicator (RCDI)
- Height sensing
- Navigation
- Weather station
- Altitude hold for UAVs
- IMU builds

Downloads & Resources

More resources, example code, the device schematic, and open-source hardware files are available from the 29124 product page at www.parallax.com.

Quick-Start Guide

The following is a very basic procedure to get started initializing and reading values from the Altimeter Module. Example test code can be found on the 29124 product page at www.parallax.com.

This module's default communication setup is I²C. Use of SPI communication is configured by pulling the PS pin low. See the datasheet for SPI configuration and use.

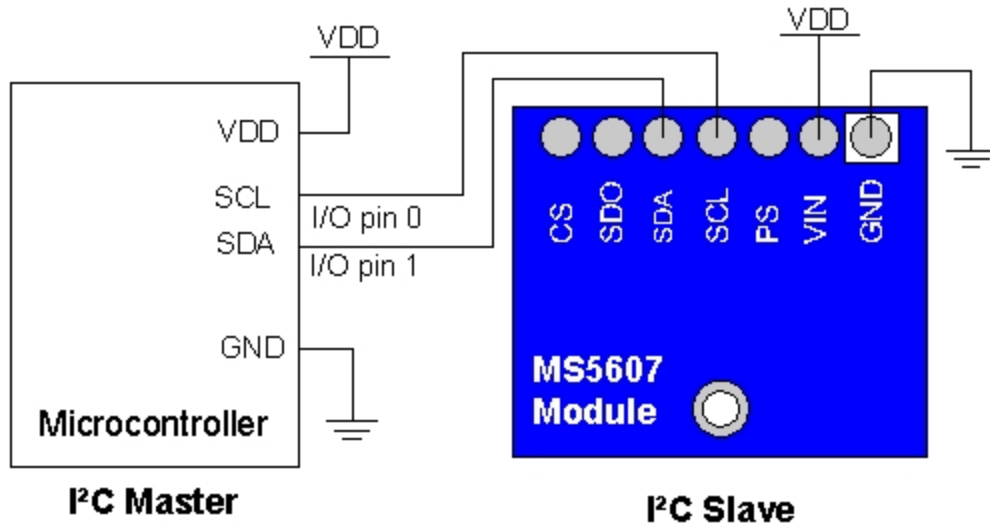

1. With main power off, make the proper connections between the module and a microcontroller as shown below. The voltage connected to the VIN pin should be the same as the voltage powering the microcontroller communicating with the device.
2. Power on the device and load the sample code provided on our product page.

NOTE: The SDA pin is connected to a bi-directional level shifting IC, used to translate the lower I/O voltage of the MS5607 to the possibly higher voltage used by an externally connected device. This particular level shifter has built-in pull-up resistors to each supply rail so it can be driven by open drain outputs for I²C; but can also be driven low/high for SPI protocol. The CLK, PS and CS pins operate exclusively as inputs, so a simpler level shifting circuit with a resistor and Schottky diode is used. For the SDO pin another simple level shifting circuit is used along with a MOSFET and two resistors.

In summary, there is no need for any external hardware to operate.

Precautions

- This sensor is moisture sensitive and was manufactured with “no-clean” solder paste. Please take steps to protect unit in wet environments.
- The pressure sensor is light sensitive; direct light will give false readings. Indirect light is okay.

Calibration

There is no need to calibrate the module since every sensor is individually factory calibrated at two temperatures and two pressures. These calibration tests are stored on the sensor itself and are part of the onboard ROM data.

Device Information

All the features of the MS5607 Altimeter IC are covered in full detail in the device datasheet.

Pin Definitions and Ratings

Pin	Name	Type	Function
1	GND	G	0 V supply, ground pin
2	VIN	P	Supply voltage from +3.3 to +6.5 VDC
3	PS	I	Protocol select: PS high (VDD) I ² C; PS low (GND) SPI
4	SCL	I	I ² C & SPI serial clock (SCL)
5	SDA/SDI	IO	Serial data input / I2C data IO
6	SDO	O	SPI serial data output (SDO)
7	CS	I	Chip select (active low), internal connection

Pin Type: P = Power, G = Ground, I = Input, O = Output

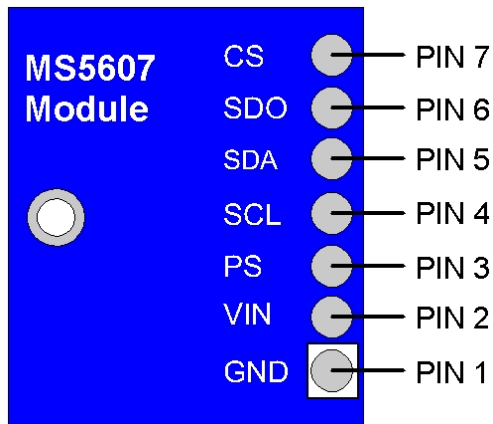

Module Dimensions

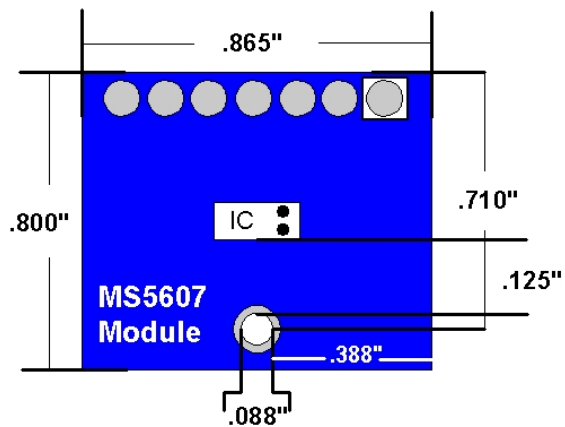

Theory of Operation

The MS5607 consists of a piezo-resistive sensor and a sensor interface IC. The main function of the MS5607 is to convert the uncompensated analogue output voltage from the piezo-resistive pressure sensor to a 24-bit digital value, as well as providing a 24-bit digital value for the temperature of the sensor.

For details on pressure and temperature calculations, please refer to the data sheet and to application note #501 located on the 29124 product page at www.parallax.com.

In order to obtain best accuracy over temperature range, particularly in low temperature, it is recommended to compensate the non-linearity over the temperature. For a full description and flow chart on setting up this compensation, see page 9 of the datasheet located on the Altimeter Module's product page at www.parallax.com.

Pressure Output Characteristics (VDD = 3V, T = 25°C)

Parameter	Conditions	Minimum	Typical	Maximum	Unit
Operating Pressure Range	Full Accuracy	300		1100	mbar
Extended Pressure Range	Linear Range of ADC	10		1200	
Total Error band, no autozero	at 25°C, 700..1100 mbar	-1.5		+1.5	
	at 0..50°C, 300..1100 mbar	-2.0		+2.0	
	at -20..85°C, 300..1100 mbar	-3.5		+3.5	
	at -40..85°C, 300..1100 mbar	-6.0		+6.0	
Total Error band, autozero at one pressure point	at 25°C, 700..1100 mbar	-0.5		+0.5	
	at 0..50°C, 300..1100 mbar	-1.0		+1.0	
	at -20..85°C, 300..1100 mbar	-2.5		+2.5	
	at -40..85°C, 300..1100 mbar	-5.0		+5.0	
Resolution RMS	Oversampling Ratio (OSR)				
	4096		0.024		
	2048		0.036		
	1024		0.054		
	512		0.084		
256		0.130			
Long-term stability			-1		mbar/yr

Table data is taken from the MS5607 datasheet.

Temperature Output Characteristics (VDD = 3V, T = 25°C)

Parameter	Conditions	Minimum	Typical	Maximum	Unit
Absolute Accuracy	at 25°C	-0.8		+0.8	°C
	-20..85°C	-2.0		+2.0	
	-40..85°C	-4.0		+4.0	
Resolution RMS	Oversampling Ratio (OSR)				
	4096		0.002		
	2048		0.003		
	1024		0.005		
	512		0.008		
256		0.012			

Table data is taken from the MS5607 datasheet.

Communication Protocol

The Altimeter Module has built in two types of serial interfaces: SPI and I²C. Pulling the Protocol Select pin PS low selects the SPI protocol. The module pulls the PS high making the default communication protocol I²C. For details on use of these communication protocols, please refer to the datasheet located on the 29124 product page.

Example Code

Example code is available for download from the 29124 product page at www.parallax.com.

C Code

Please see application note “APPNote_520_C_code.pdf” on the 29124 product page for C code examples using Measurement Specialties Altimeters.

Propeller™ P8X32A

The Altimeter_Demo_and_Driver.zip contains 29124_simple_altimeter_demo.spin file which is a simple demonstration showing altitude with a configurable starting altitude. Also contained in the zip file is an HTML file “29124_altimeter.html” that goes over in detail about the altimeter driver used in the demo code.

The Demo programs use Parallax Serial Terminal to display the device output. The object and the Parallax Serial Terminal itself are included with the with the Propeller Tool v1.2.7 or higher, which is available from the Downloads link at www.parallax.com/Propeller.