



Chipsmall Limited consists of a professional team with an average of over 10 year of expertise in the distribution of electronic components. Based in Hongkong, we have already established firm and mutual-benefit business relationships with customers from,Europe,America and south Asia,supplying obsolete and hard-to-find components to meet their specific needs.

With the principle of “Quality Parts,Customers Priority,Honest Operation,and Considerate Service”,our business mainly focus on the distribution of electronic components. Line cards we deal with include Microchip,ALPS,ROHM,Xilinx,Pulse,ON,Everlight and Freescale. Main products comprise IC,Modules,Potentiometer,IC Socket,Relay,Connector.Our parts cover such applications as commercial,industrial, and automotives areas.

We are looking forward to setting up business relationship with you and hope to provide you with the best service and solution. Let us make a better world for our industry!



## Contact us

Tel: +86-755-8981 8866 Fax: +86-755-8427 6832

Email & Skype: info@chipsmall.com Web: www.chipsmall.com

Address: A1208, Overseas Decoration Building, #122 Zhenhua RD., Futian, Shenzhen, China



## Control cabinet - RAD-SOL-BOX-24V-BLANK - 2917052

Please be informed that the data shown in this PDF Document is generated from our Online Catalog. Please find the complete data in the user's documentation. Our General Terms of Use for Downloads are valid (<http://phoenixcontact.com/download>)



Aluminum cabinet for use outdoors. Designed for use in solar set RAD-SOL-SET-24-...

The illustration shows the article with further components

### Product Features

- Control cabinet for outdoor use, white powder-coated finish, lockable
- 



### Key commercial data

Packing unit	1 pc
Weight per Piece (excluding packing)	15000.0 GRM
Custom tariff number	85381000
Country of origin	Germany

### Technical data

#### Dimensions

Width	500 mm
Height	760 mm
Depth	332 mm

#### Control cabinet / System

Width	500 mm
Height	760 mm
Depth	332 mm
Net weight	17 kg
Housing material	Aluminum

# Control cabinet - RAD-SOL-BOX-24V-BLANK - 2917052

## Classifications

### eCl@ss

eCl@ss 4.0	27060805
eCl@ss 4.1	27060805
eCl@ss 5.0	27061805
eCl@ss 5.1	27061805
eCl@ss 6.0	27061805
eCl@ss 7.0	27061805

### ETIM

ETIM 2.0	EC000019
ETIM 3.0	EC000019
ETIM 4.0	EC000019
ETIM 5.0	EC000019

### UNSPSC

UNSPSC 6.01	26121608
UNSPSC 7.0901	26121608
UNSPSC 11	26121608
UNSPSC 12.01	26121608
UNSPSC 13.2	26121608

## Approvals

### Approvals

---

Approvals

UL Listed / cUL Listed / cULus Listed

---

Ex Approvals

---

Approvals submitted

---

### Approval details

UL Listed 
---

# Control cabinet - RAD-SOL-BOX-24V-BLANK - 2917052

## Approvals



## Drawings

Schematic diagram

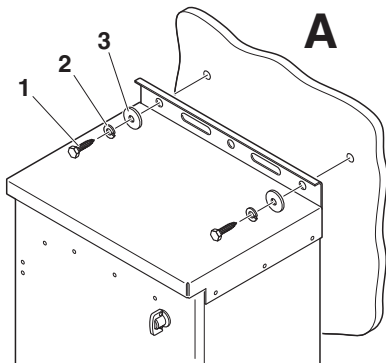

Wall mounting

Schematic diagram

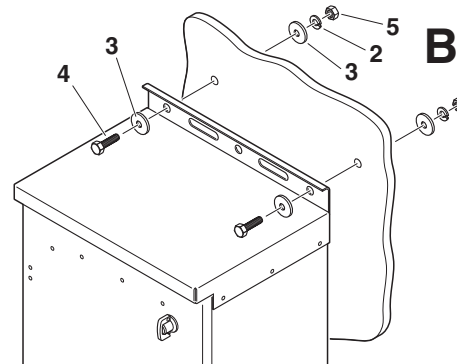

Wall mounting

## Control cabinet - RAD-SOL-BOX-24V-BLANK - 2917052

Schematic diagram

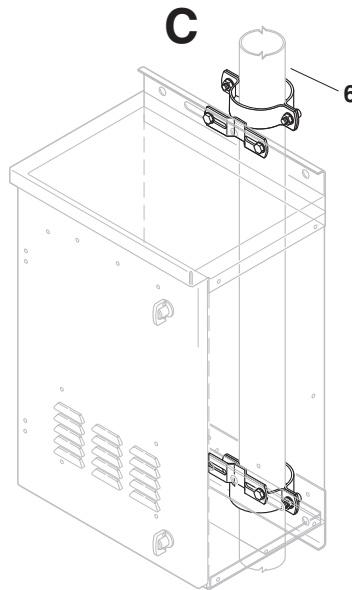

Assembly