



Chipsmall Limited consists of a professional team with an average of over 10 year of expertise in the distribution of electronic components. Based in Hongkong, we have already established firm and mutual-benefit business relationships with customers from,Europe,America and south Asia,supplying obsolete and hard-to-find components to meet their specific needs.

With the principle of “Quality Parts,Customers Priority,Honest Operation,and Considerate Service”,our business mainly focus on the distribution of electronic components. Line cards we deal with include Microchip,ALPS,ROHM,Xilinx,Pulse,ON,Everlight and Freescale. Main products comprise IC,Modules,Potentiometer,IC Socket,Relay,Connector.Our parts cover such applications as commercial,industrial, and automotives areas.

We are looking forward to setting up business relationship with you and hope to provide you with the best service and solution. Let us make a better world for our industry!



## Contact us

Tel: +86-755-8981 8866 Fax: +86-755-8427 6832

Email & Skype: info@chipsmall.com Web: www.chipsmall.com

Address: A1208, Overseas Decoration Building, #122 Zhenhua RD., Futian, Shenzhen, China



291EX

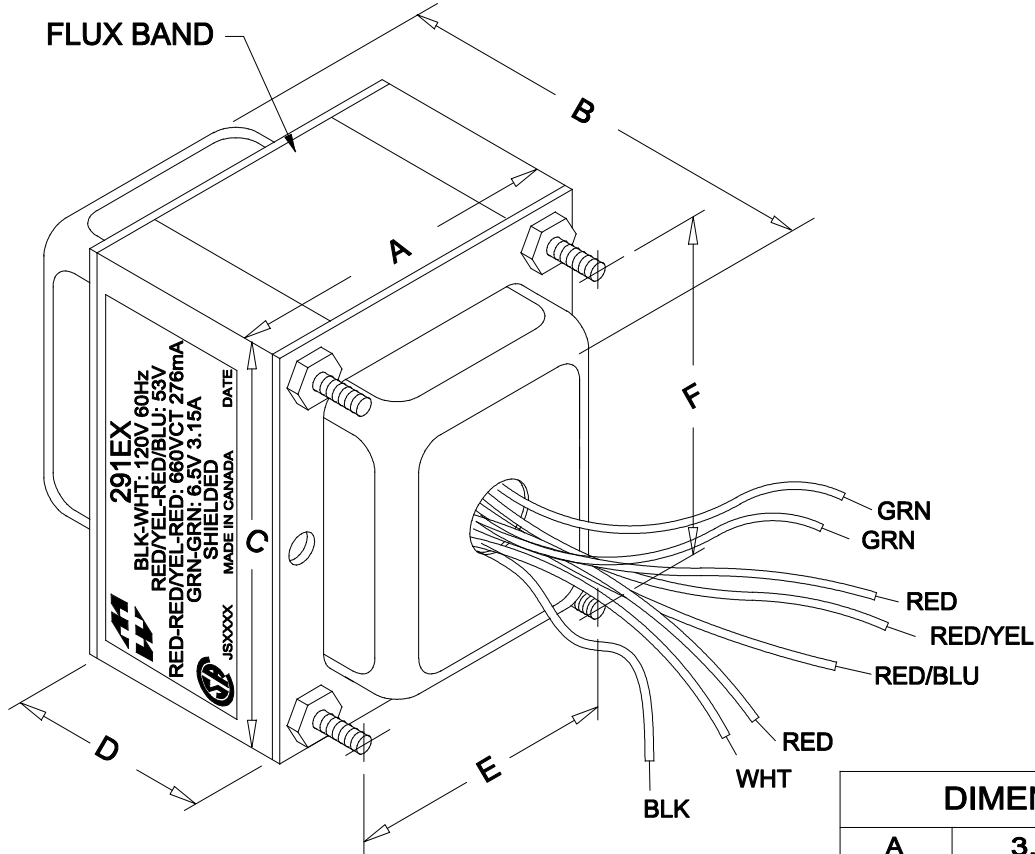

DIMENSIONS:	
A	3.438" ±0.063
B	4.063" ±0.125
C	4.125" ±0.063
D	1.844" ±0.063
E	2.750" ±0.063
F	3.438" ±0.063

NOTE: ALL LEADS 9" OUT MIN., STRIPPED .5"

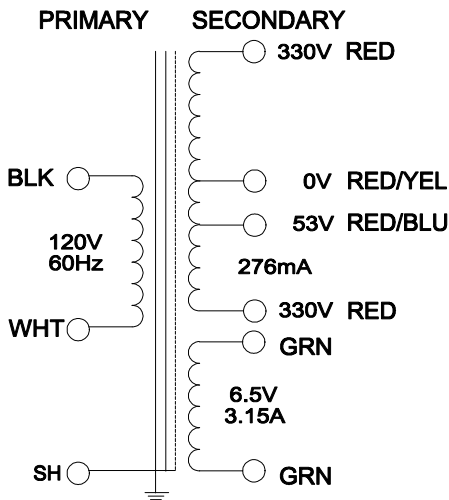

ELECTRICAL DATA:	
Turns ratio:	1 : 5.74 ( RED - RED)
Exciting Current	@ 120V, 60Hz, BLK - WHT = 398mA Max.
DCR	@ 20C, BLK - WHT = 1.415 Ω ±20%
	@ 20C, RED - RED = 40.13 Ω ±20%
	@ 20C, GRN - GRN = 0.060 Ω ±20%
Pri. Voltage	120V 60Hz
Sec. Voltage (RMS)	660VCT @ 276mA C/W 53V TAP , 6.5V @ 3.15A
No Load Voltage	688.70VCT/ 6.78V

**HAMMOND  
MANUFACTURING**

52 RANKIN PLACE,  
WATERLOO, ONTARIO, N2L 3Z5.

PHONE (519) 886-6181  
FAX # (519) 886-9540

TITLE		291EX		291EX
			DR BY B.Pervaiz	
			DATE 08/25/09	
NO	DATE	REVISION	DIM IN(X)MM( )	