



Chipsmall Limited consists of a professional team with an average of over 10 year of expertise in the distribution of electronic components. Based in Hongkong, we have already established firm and mutual-benefit business relationships with customers from,Europe,America and south Asia,supplying obsolete and hard-to-find components to meet their specific needs.

With the principle of “Quality Parts,Customers Priority,Honest Operation,and Considerate Service”,our business mainly focus on the distribution of electronic components. Line cards we deal with include Microchip,ALPS,ROHM,Xilinx,Pulse,ON,Everlight and Freescale. Main products comprise IC,Modules,Potentiometer,IC Socket,Relay,Connector.Our parts cover such applications as commercial,industrial, and automotives areas.

We are looking forward to setting up business relationship with you and hope to provide you with the best service and solution. Let us make a better world for our industry!



## Contact us

Tel: +86-755-8981 8866 Fax: +86-755-8427 6832

Email & Skype: info@chipsmall.com Web: www.chipsmall.com

Address: A1208, Overseas Decoration Building, #122 Zhenhua RD., Futian, Shenzhen, China



THIS DRAWING IS UNPUBLISHED. RELEASED FOR PUBLICATION 2006  
 © COPYRIGHT 2006 BY TYCO ELECTRONICS CORPORATION. ALL RIGHTS RESERVED.

LOC	DIST	REVISIONS					
		P	LTR	DESCRIPTION	DATE	DWN	APVD
1	-		0	FIRST ISSUE	27APR2006	UA	GT

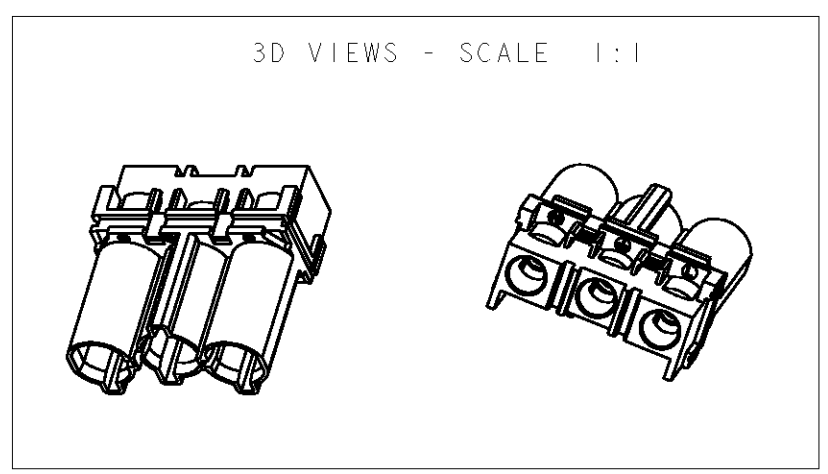
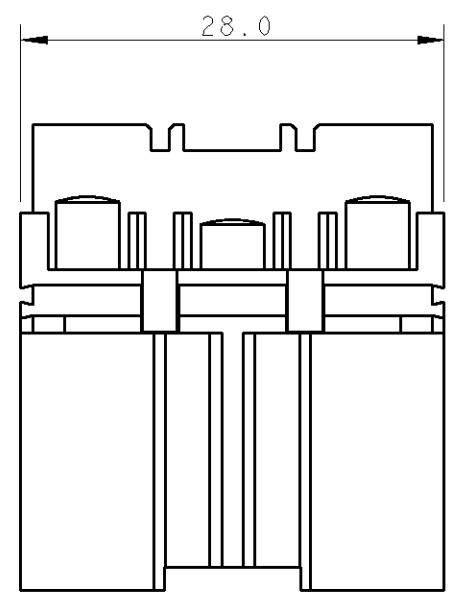
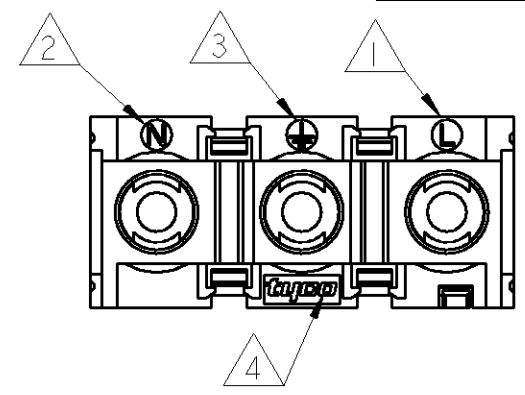
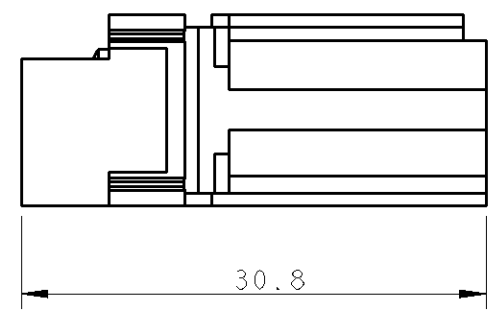
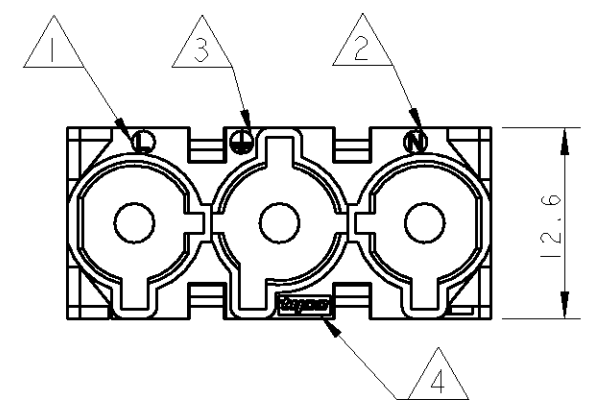

NOTES:

- 1 LINE SYMBOL
- 2 NEUTRAL SYMBOL
- 3 PE SYMBOL
- 4 TYCO TRADEMARK
- 5) PACKAGING ACCORDING TO TYCO SPEC. 107-20252
- 6) FOR FREE-HANGING VERSION (SEE SHEET 2 OF 2) TYCO NECTOR\* HERMAPH. SHELL P/N 293054 MUST BE USED
- 7) FOR PANEL MOUNT VERSION (SEE SHEET 2 OF 2) TYCO NECTOR\* PANEL MOUNT FRAME P/N 293053 MUST BE USED
- 8) FOR INSTALLATIONS ACCORDING TO VDE 0606-200 LOCKING DEVICES P/N 293129 (FREE-HANGING VERSION) OR P/N 293130 (PANEL MOUNT VERSION) MUST BE USED

- INSULATION DIA < 9.0 mm:  
REMOVE INSULATION JACKET FOR A LENGTH OF 20 ± 1 mm
- INSULATION DIA ≥ 9.0 mm:  
REMOVE INSULATION JACKET FOR A LENGTH OF 30 ± 1 mm
- STRIP WIRES FOR A LENGTH OF 5 mm
- CRIMP CONTACTS - SEE APPLICATION SPEC. 114-74003  
P/N 4-1105100-3 FOR 2.5 sqmm WIRE  
P/N 3-1105100-3 FOR 1.5 sqmm WIRE
- INSERT CONTACTS INTO CONNECTOR CAVITIES

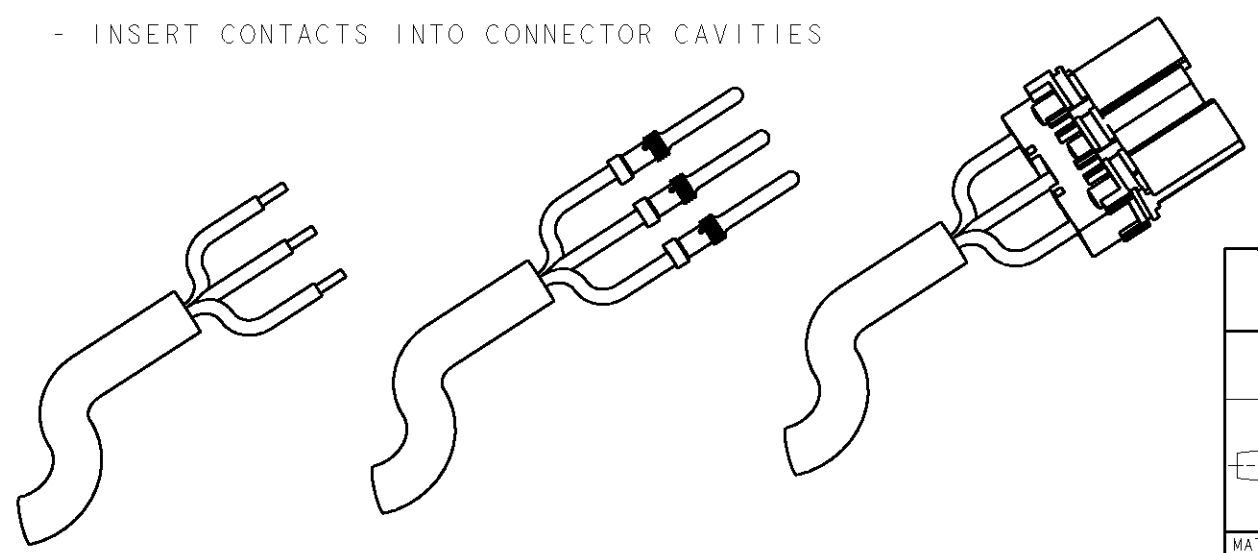

293051-2	WHITE	A
293051-1	BLACK	A
TYCO P/N	COLOUR	REV.

DIMENSIONS:		TOLERANCES UNLESS OTHERWISE SPECIFIED:		DWN		APVD		PRODUCT SPEC		APPLICATION SPEC		WEIGHT		CUSTOMER DRAWING	
mm		0 PLC	±-	U.A.I.M.E	27APR2006	G.TURCO		-		-		-		-	
		1 PLC	±0.3	U.A.I.M.E	27APR2006			-		-		-		-	
		2 PLC	±-					-		-		-		-	
		3 PLC	±-					-		-		-		-	
		4 PLC	±-					-		-		-		-	
		ANGLES	±1					-		-		-		-	
		FINISH	-					-		-		-		-	

**tyco** AMP Italia S.p.A.  
**Electronics** C.so F.lli Cervi 15 Collegno (TO)

NAME: TYCO NECTOR\* 3 POS. RECPT. HOUSING FOR C.O.S.I. CONTACTS

SIZE	CAGE CODE	DRAWING NO	RESTRICTED TO
A3	00779	C=293051	-

SCALE 2:1 SHEET 1 OF 2 REV 0

THIS DRAWING IS UNPUBLISHED.

RELEASED FOR PUBLICATION

2006

© COPYRIGHT 2006

BY TYCO ELECTRONICS CORPORATION. ALL RIGHTS RESERVED.

LOC	DIST	REVISIONS			
P	LTR	DESCRIPTION	DATE	DWN	APVD
1	-				

FREE HANGING VERSION  
1.5 / 2.5 sqmm WIRE SIZE ONLY

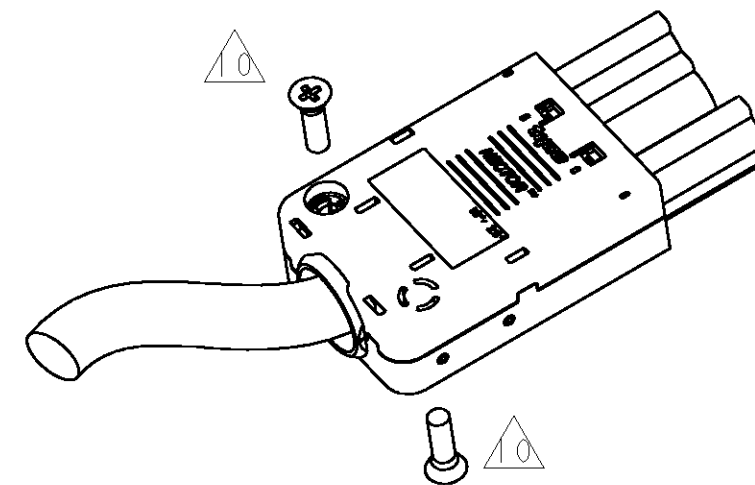
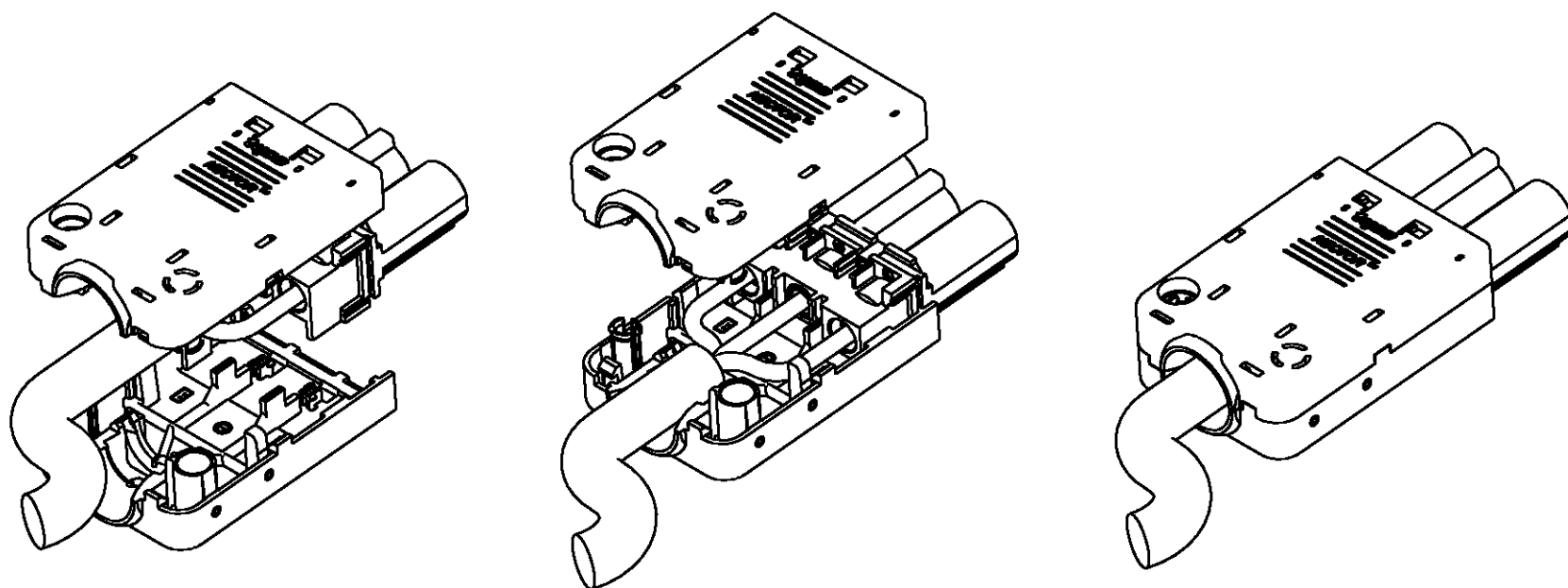

OPTIONAL SCREWS M3 x 12 - NOT INCLUDED  
(SCREWS ACCORDING TO: "UNI 9709" OR  
"UNI 9707" OR "UNI 10228" OR "UNI 10227")

PANEL MOUNT VERSION

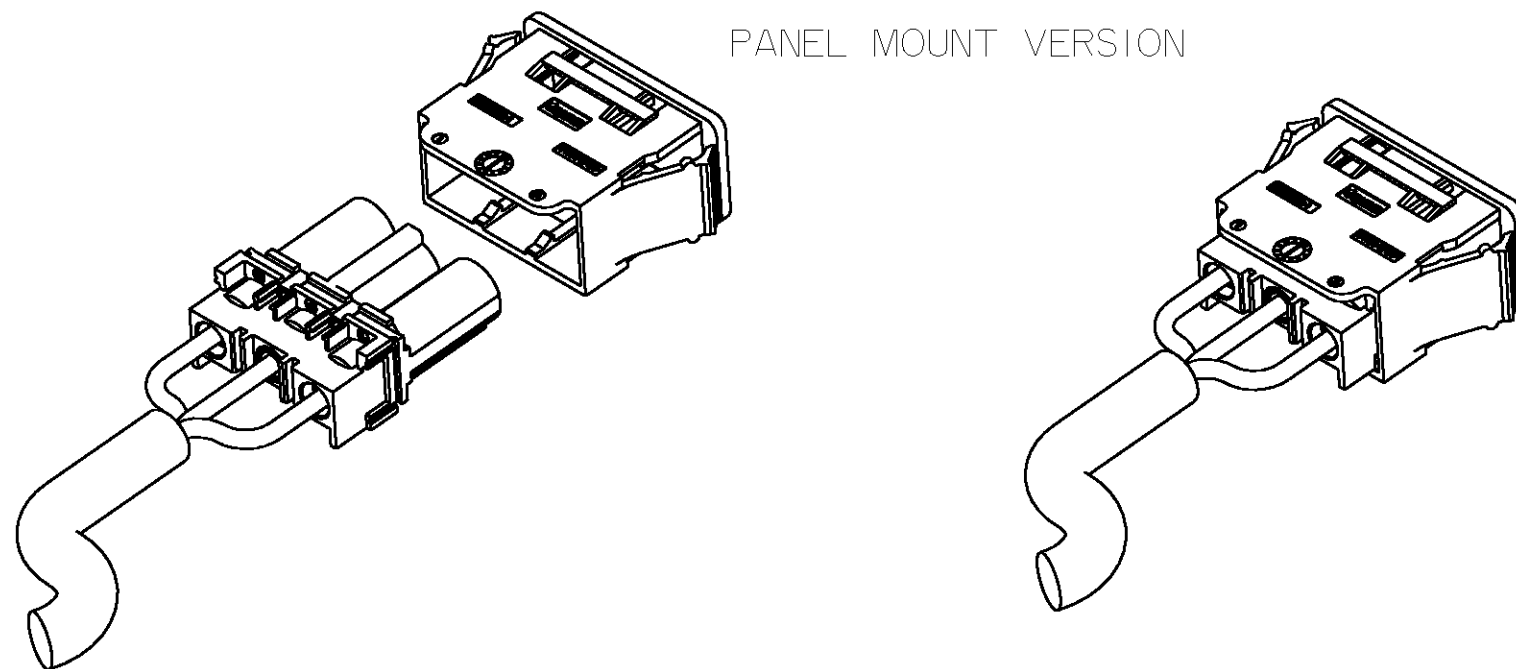

THIS DRAWING IS A CONTROLLED DOCUMENT FOR TYCO ELECTRONICS CORPORATION  
IT IS SUBJECT TO CHANGE AND THE CONTROLLING ENGINEERING ORGANIZATION  
SHOULD BE CONTACTED FOR THE LATEST REVISION.

DIMENSIONS: mm		TOLERANCES UNLESS OTHERWISE SPECIFIED:	
		0 PLC	±-
		1 PLC	±0.3
		2 PLC	±-
		3 PLC	±-
		4 PLC	±-
MATERIAL -		ANGLES	±1
		FINISH	-

DWN	U.A.I.M.E.	27APR2006
CHK	U.A.I.M.E.	27APR2006
APVD	G.TURCO	27APR2006
PRODUCT SPEC	-	
APPLICATION SPEC	-	
WEIGHT	-	
CUSTOMER DRAWING		

<b>tyco</b> <b>Electronics</b>		AMP Italia S.p.A. C.so F.lli Cervi 15 Collegno (TO)	
NAME TYCO NECTOR* 3 POS. RECPT HOUSING FOR C.O.S.I. CONTACTS			
SIZE	CAGE CODE	DRAWING NO	RESTRICTED TO
A3	00779	C=293051	-
SCALE 2:1		SHEET 2 OF 2	REV 0