



Chipsmall Limited consists of a professional team with an average of over 10 year of expertise in the distribution of electronic components. Based in Hongkong, we have already established firm and mutual-benefit business relationships with customers from,Europe,America and south Asia,supplying obsolete and hard-to-find components to meet their specific needs.

With the principle of "Quality Parts,Customers Priority,Honest Operation,and Considerate Service",our business mainly focus on the distribution of electronic components. Line cards we deal with include Microchip,ALPS,ROHM,Xilinx,Pulse,ON,Everlight and Freescale. Main products comprise IC,Modules,Potentiometer,IC Socket,Relay,Connector.Our parts cover such applications as commercial,industrial, and automotives areas.

We are looking forward to setting up business relationship with you and hope to provide you with the best service and solution. Let us make a better world for our industry!



Contact us

Tel: +86-755-8981 8866 Fax: +86-755-8427 6832

Email & Skype: info@chipsmall.com Web: www.chipsmall.com

Address: A1208, Overseas Decoration Building, #122 Zhenhua RD., Futian, Shenzhen, China



THIS DRAWING IS UNPUBLISHED. RELEASED FOR PUBLICATION 2006
 © COPYRIGHT 2006 BY TYCO ELECTRONICS CORPORATION, ALL RIGHTS RESERVED.

LOC	DIST	REVISIONS			
P	LTR	DESCRIPTION	DATE	DWN	APVD
1	-				
	0	FIRST ISSUE	11APR2006	UA	GT
	B	ECR-10-021916	25OCT2010	UA	GT

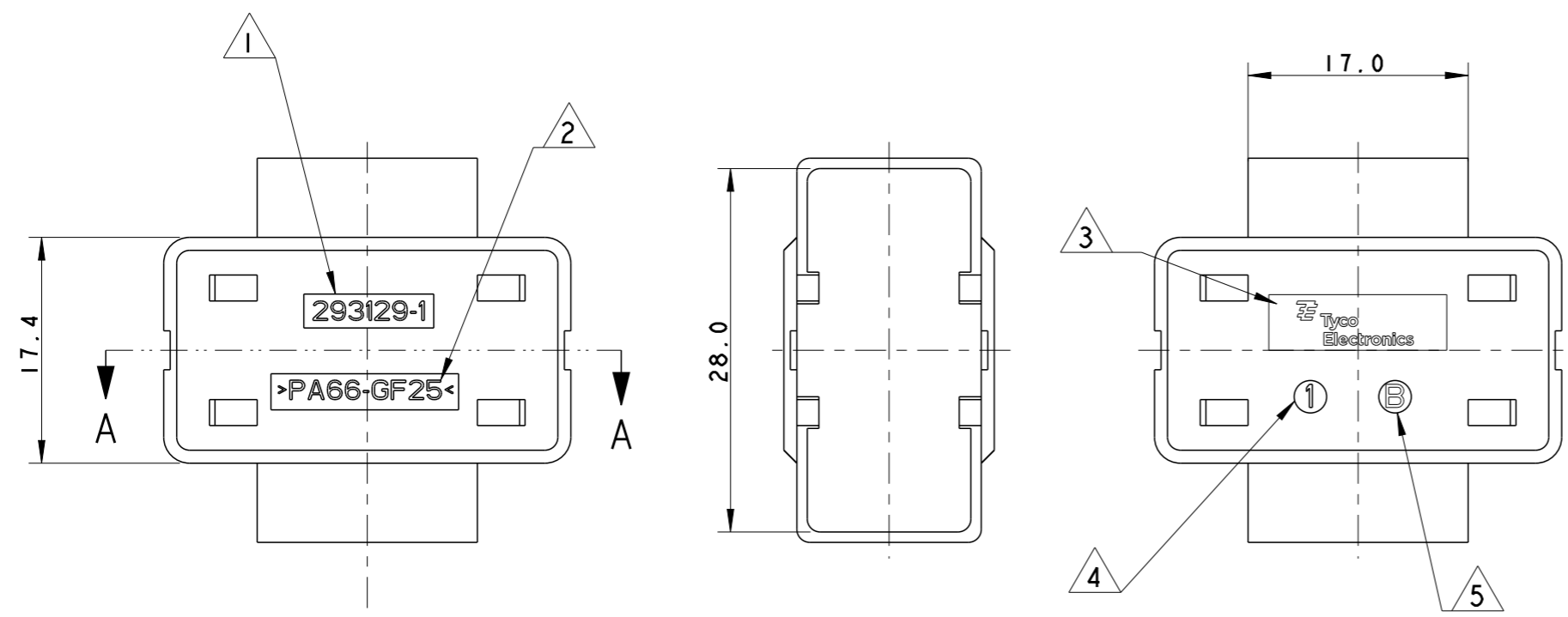

- NOTES:
- 1) TE P/N
 - 2) RAW MAT'L CODE
 - 3) TE TRADEMARK
 - 4) MOULD CAVITY IDENTIFICATION
 - 5) PART REVISION
 - 6) TO BE USED FOR INSTALLATIONS ACCORDING TO VDE 0606-200
 - 7) USED ON CONNECTORS FREE HANGING VERSION
 - 8) PACKAGED ACCORDING TO TYCO SPEC. 107-2052
 - 9) ACCORDING TO VDE 0606-200 NORM, LOCKING DEVICE MUST NOT BE EASILY REMOVABLE BY HAND; A COMMON TOOL WOULD BE NECESSARY (e.g.: SCREWDRIVER)

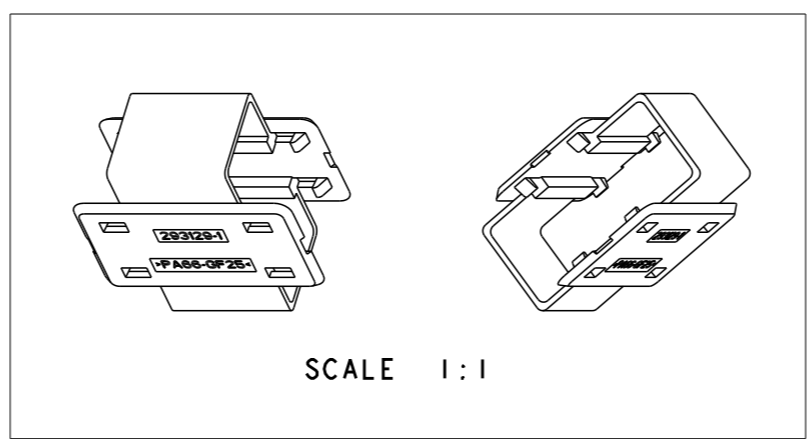
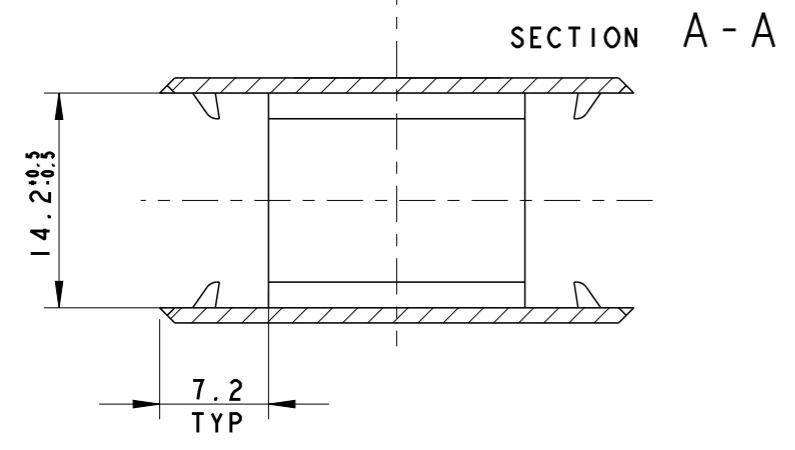

293129-2	WHITE	B
293129-1	BLACK	B
TYCO P/N	COLOUR	PART REV.

THIS DRAWING IS A CONTROLLED DOCUMENT FOR TYCO ELECTRONICS CORPORATION IT IS SUBJECT TO CHANGE AND THE CONTROLLING ENGINEERING ORGANIZATION SHOULD BE CONTACTED FOR THE LATEST REVISION.

DWN	U. AIME	11APR2006	AMP Italia S.p.A. C.so F.lli Cervi 15 Collegno (TO)
CHK	U. AIME	11APR2006	
APVD	G. TURCO	11APR2006	
PRODUCT SPEC	108-20268		NAME
APPLICATION SPEC	-		LOCKING FOR TYCO NECTOR* HERMAPHRODITE SHELL
WEIGHT	-		SIZE
CUSTOMER DRAWING	A300779		CAGE CODE
	C-293129		DRAWING NO
	SCALE	2:1	RESTRICTED TO
	SHEET	1 OF 1	REV
			B