



Chipsmall Limited consists of a professional team with an average of over 10 year of expertise in the distribution of electronic components. Based in Hongkong, we have already established firm and mutual-benefit business relationships with customers from,Europe,America and south Asia,supplying obsolete and hard-to-find components to meet their specific needs.

With the principle of “Quality Parts,Customers Priority,Honest Operation,and Considerate Service”,our business mainly focus on the distribution of electronic components. Line cards we deal with include Microchip,ALPS,ROHM,Xilinx,Pulse,ON,Everlight and Freescale. Main products comprise IC,Modules,Potentiometer,IC Socket,Relay,Connector.Our parts cover such applications as commercial,industrial, and automotives areas.

We are looking forward to setting up business relationship with you and hope to provide you with the best service and solution. Let us make a better world for our industry!



Contact us

Tel: +86-755-8981 8866 Fax: +86-755-8427 6832

Email & Skype: info@chipsmall.com Web: www.chipsmall.com

Address: A1208, Overseas Decoration Building, #122 Zhenhua RD., Futian, Shenzhen, China



MicroTouch™ CT150 Touch Monitor Dimensional Drawings



CONTENTS:

- 11-71315-225-00* – CT150 USB with no Bezel
- 11-71315-227-00* – CT150 Serial with no Bezel
- 11-71315-225-01** – CT150 USB with Slimline Bezel
- 11-71315-227-01** – CT150 Serial with Slimline Bezel
- N/A – Contour Flanged Bezel
- 11-71315-225-03** – CT150 USB with Contour Bezel
- 29369** – Contour Flanged Bezel
- N/A – CT150 with Industrial Bezel (Reference only)
- 29368** – Industrial Flanged Bezel
- 30113** – Heavy-duty Mounting Bracket
- N/A – Angle Mounting Bracket (ships with all products)

* Available only in Europe
** Available worldwide



MicroTouch
www.CT150monitor.com

UNITS INCHES [MM]		 3M TOUCH SYSTEMS METHUEN, MA USA <small>© COPYRIGHT 2003 THIS DOCUMENT IS COPYRIGHTED PROPERTY OF THE 3M COMPANY AND MAY NOT BE REPRODUCED WITHOUT 3M WRITTEN PERMISSION OR USED OR DISCLOSED FOR OTHER THAN 3M AUTHORIZED PURPOSES.</small>	REV INITIAL RELEASE PER ECO XXXXXX	XX/XX/XX	XX
TOLERANCES UNLESS OTHERWISE SPECIFIED			REV CHANGE NOTICE	DATE	DRW
.X	±0.1	TITLE			
.XX	±0.01	THIRD ANGLE PROJECTION 			
.XXX	±0.005				
ANGLES	±0.5°				
DO NOT SCALE DRAWING		DRWN	CAD FORMAT	SHEET 1 OF 1	
SCALE 1 = 1		SIZE C	DOCUMENT NO.	REV I	REV I

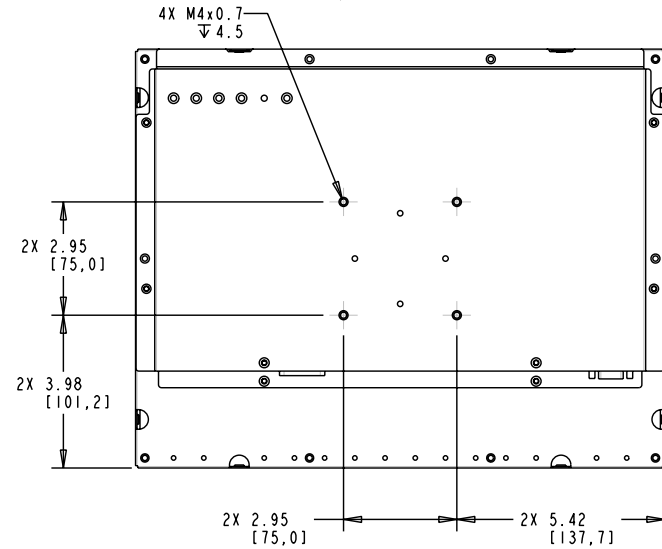
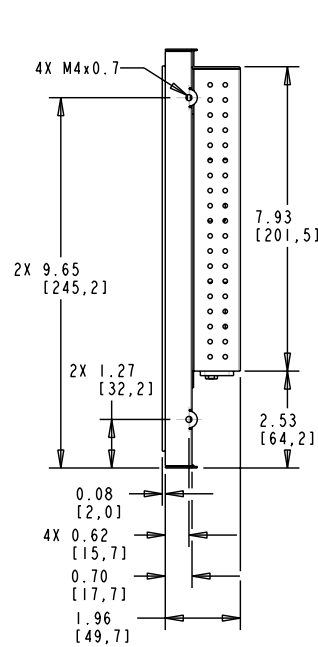
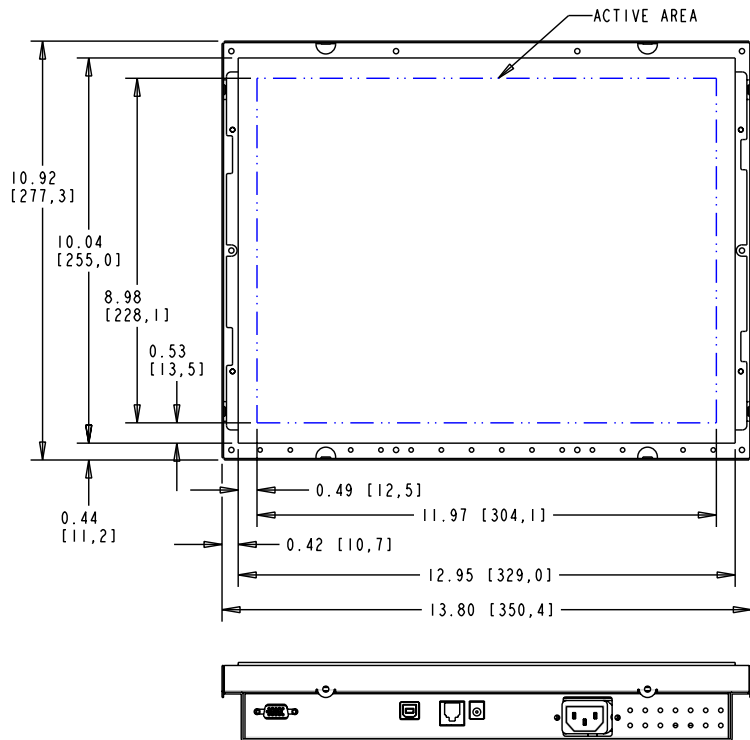
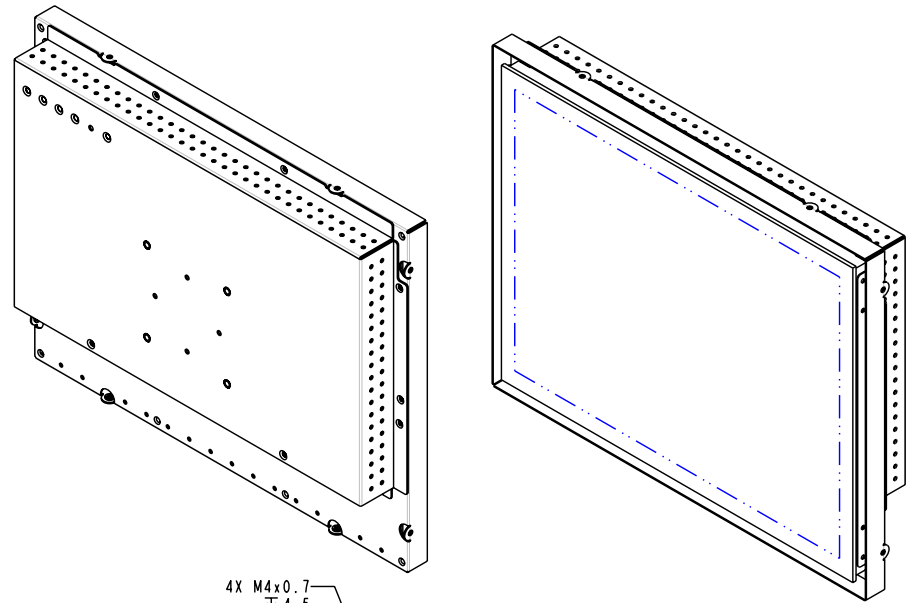
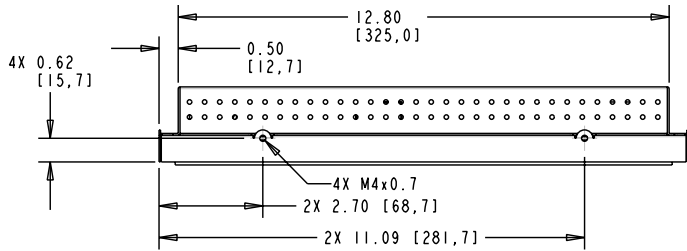

MicroTouch
www.CT150monitor.com

UNITS	INCHES [MM]
TOLERANCES UNLESS OTHERWISE SPECIFIED	
.X	±0.1
.XX	±0.01
.XXX	±0.005
ANGLES	±0.5°
THIRD ANGLE PROJECTION	
DO NOT SCALE DRAWING	
SCALE	1 = 1

3M 3M TOUCH SYSTEMS
METHUEN, MA
USA
© COPYRIGHT 2003
THIS DOCUMENT IS COPYRIGHTED PROPERTY OF THE 3M COMPANY AND MAY NOT BE REPRODUCED WITHOUT 3M WRITTEN PERMISSION OR USED OR DISCLOSED FOR OTHER THAN 3M AUTHORIZED PURPOSES.

REV	INITIAL RELEASE PER ECO XXXXXX	XX/XX/XX	XX
REV	CHANGE NOTICE	DATE	DWG
TITLE			
CT150 USB TOUCH MONITOR WITHOUT BEZEL			
CAD FORMAT	SHEET 1 OF 1		
SIZE	DOCUMENT NO.	REV	
C	11-71315-225-00	REV I	

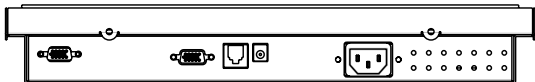
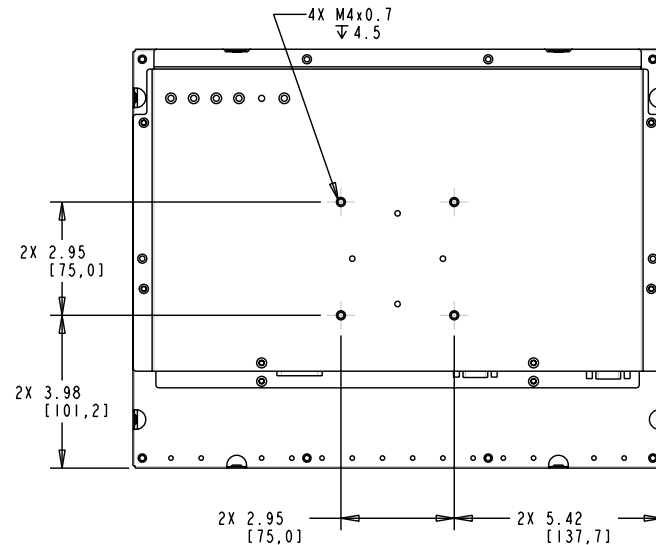
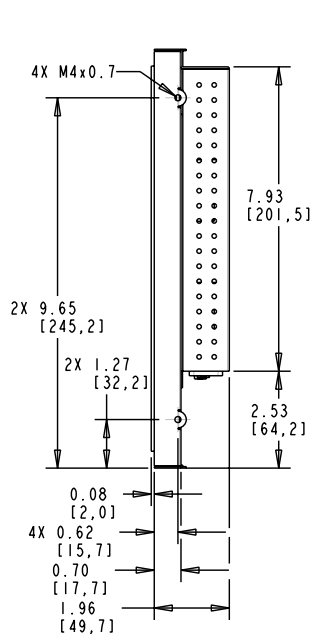
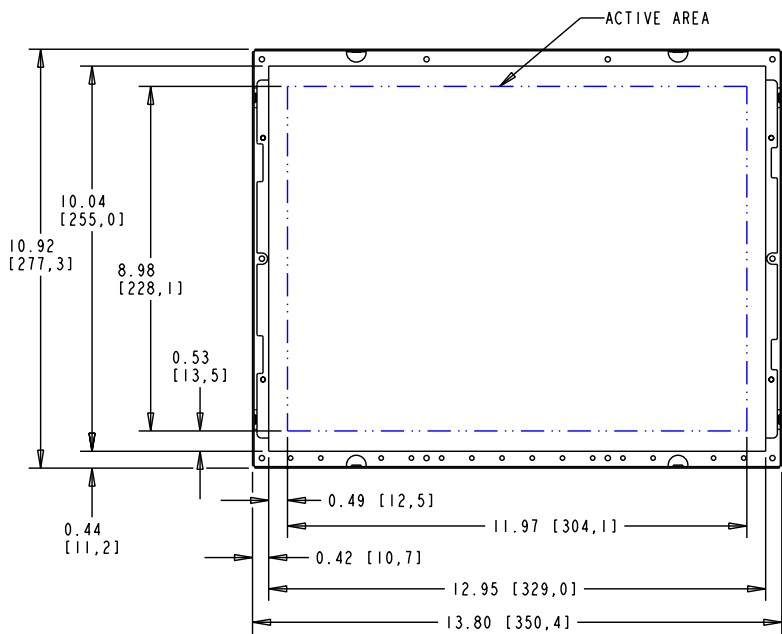
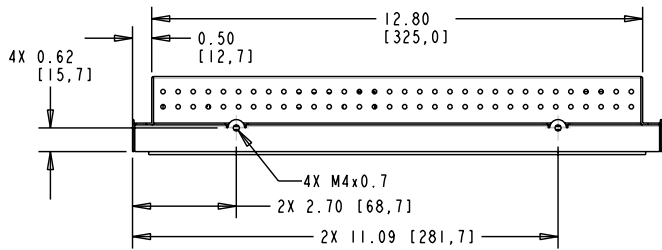
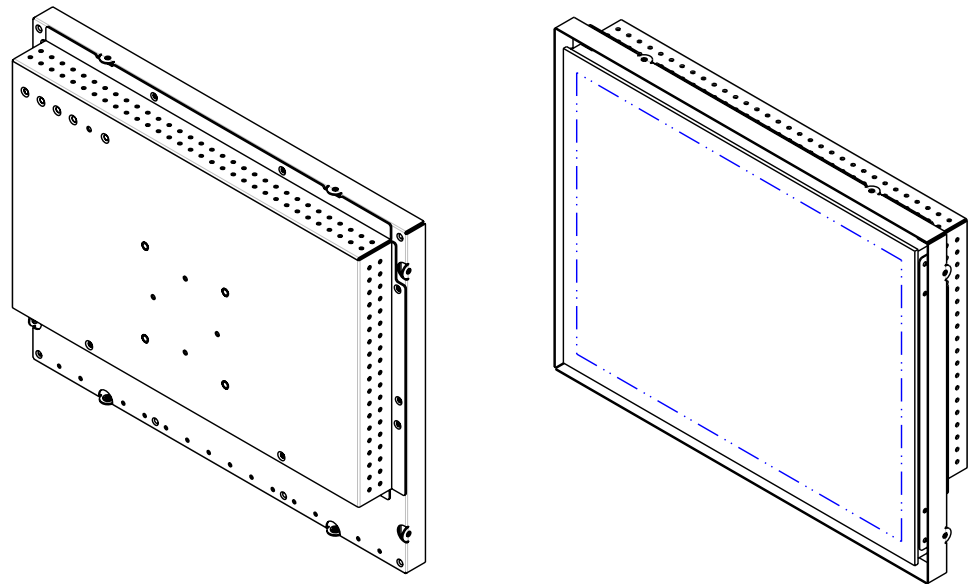

MicroTouch
www.CT150monitor.com

UNITS	INCHES [MM]	3M TOUCH SYSTEMS METHUEN, MA USA <small>© COPYRIGHT 2003 THIS DOCUMENT IS COPYRIGHTED PROPERTY OF THE 3M COMPANY AND MAY NOT BE REPRODUCED WITHOUT 3M WRITTEN PERMISSION OR USED OR DISCLOSED FOR OTHER THAN 3M AUTHORIZED PURPOSES.</small>
TOLERANCES UNLESS OTHERWISE SPECIFIED	.X ±0.1 .XX ±0.01 .XXX ±0.005 ANGLES ±0.5°	
THIRD ANGLE PROJECTION		
DO NOT SCALE DRAWING	SCALE 1 = 1	

REV	INITIAL RELEASE PER ECO XXXXXX	XX/XX/XX	XX
REV	CHANGE NOTICE	DATE	DWG
TITLE			
CT150 SERIAL TOUCH MONITOR WITHOUT BEZEL			
CAD FORMAT	SHEET 1 OF 1		REV
SIZE	DOCUMENT NO.	11-71315-227-00	REV I

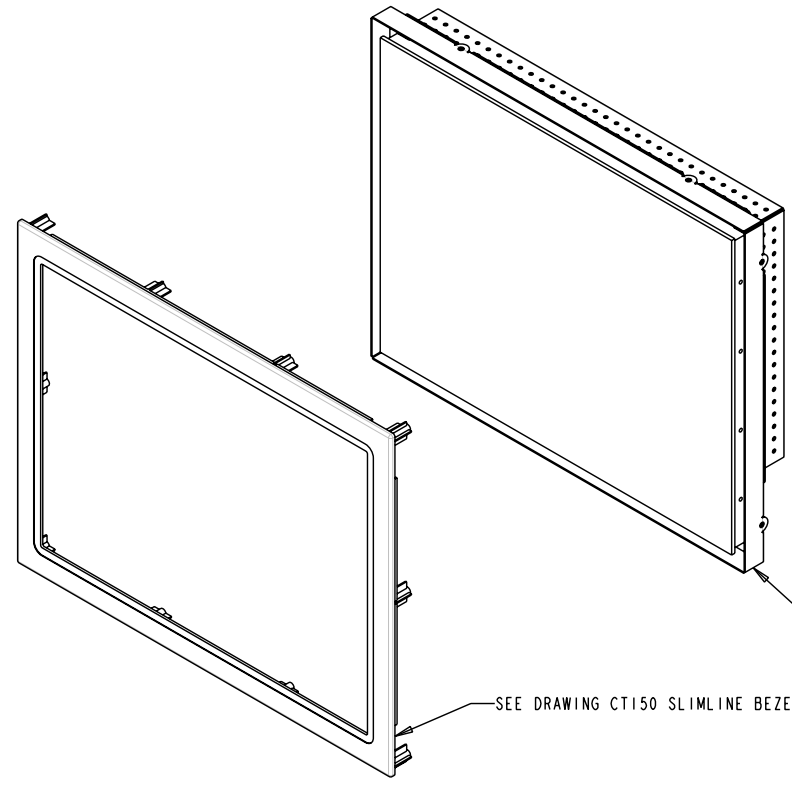
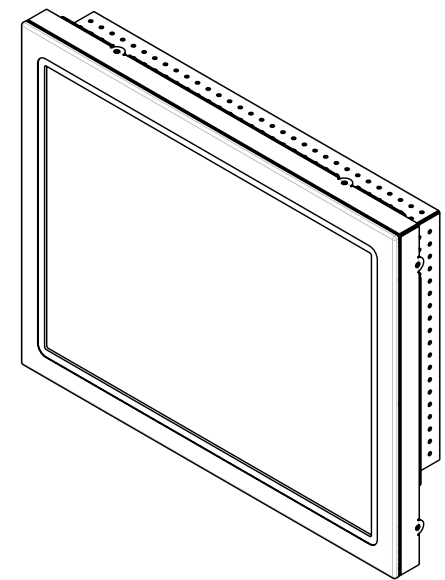

SEE DRAWING 11-71315-225-00 CT150 USB

SEE DRAWING CT150 SLIMLINE BEZEL

MicroTouch
www.CT150monitor.com

UNITS	INCHES [MM]
TOLERANCES UNLESS OTHERWISE SPECIFIED	
.X	± 0.1
.XX	± 0.01
.XXX	± 0.005
ANGLES	± 0.5°
THIRD ANGLE PROJECTION	
DO NOT SCALE DRAWING	
SCALE	1 = 1

3M 3M TOUCH SYSTEMS
METHUEN, MA
USA
© COPYRIGHT 2003
THIS DOCUMENT IS COPYRIGHTED PROPERTY OF THE 3M COMPANY AND MAY NOT BE REPRODUCED WITHOUT 3M WRITTEN PERMISSION OR USED OR DISCLOSED FOR OTHER THAN 3M AUTHORIZED PURPOSES.

REV	INITIAL RELEASE PER ECO XXXXXX	XX/XX/XX	XX
REV	CHANGE NOTICE	DATE	DWG
TITLE			
CT150 USB TOUCH MONITOR SLIMLINE BEZEL			
CAD FORMAT		SHEET 1 OF 1	
SIZE	DOCUMENT NO.	REV	
C	11-71315-225-01	REV I	

4

3

2

1

D

D

C

C

B

B

A

A

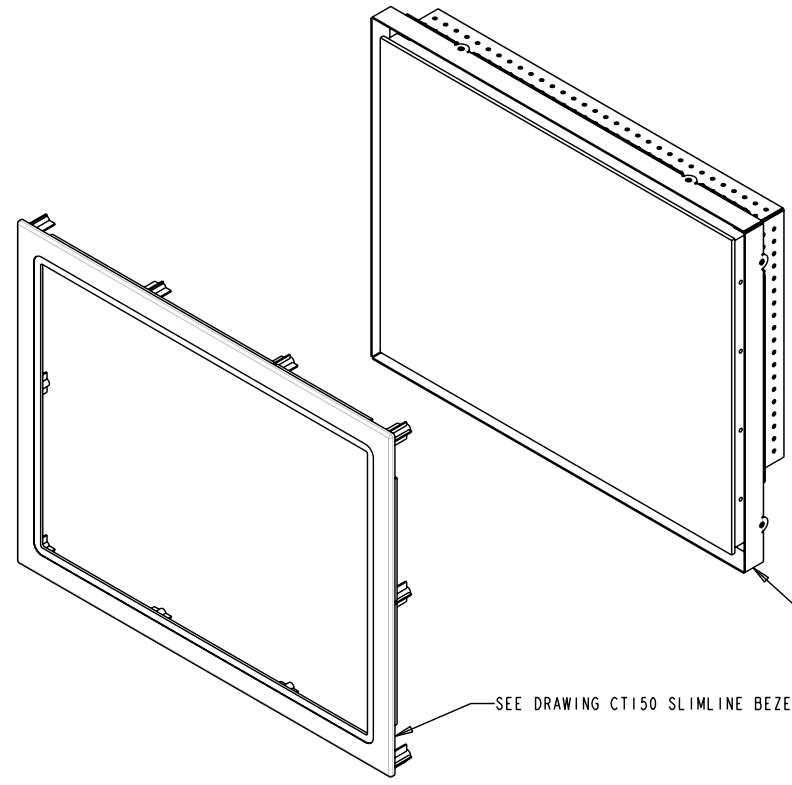
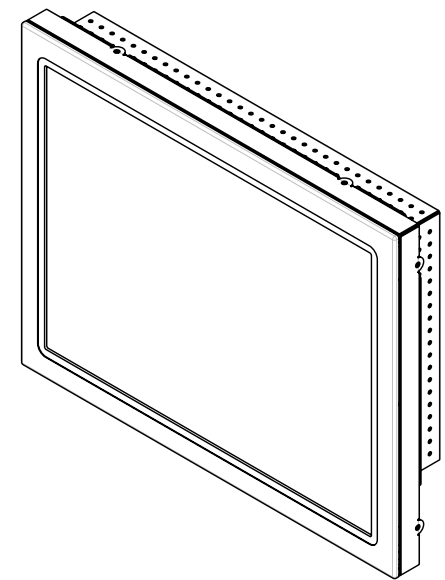

SEE DRAWING 11-71315-227-00 CT150 SERIAL

SEE DRAWING CT150 SLIMLINE BEZEL

MicroTouch
www.CT150monitor.com

UNITS	INCHES [MM]
TOLERANCES UNLESS OTHERWISE SPECIFIED	
.X	± 0.1
.XX	± 0.01
.XXX	± 0.005
ANGLES	± 0.5°
THIRD ANGLE PROJECTION	
DO NOT SCALE DRAWING	
SCALE	1 = 1

3M 3M TOUCH SYSTEMS
METHUEN, MA
USA
© COPYRIGHT 2003
THIS DOCUMENT IS COPYRIGHTED PROPERTY OF THE 3M COMPANY AND MAY NOT BE REPRODUCED WITHOUT 3M WRITTEN PERMISSION OR USED OR DISCLOSED FOR OTHER THAN 3M AUTHORIZED PURPOSES.

REV	INITIAL RELEASE PER ECO XXXXXX	XX/XX/XX	XX
REV	CHANGE NOTICE	DATE	DWG
TITLE			
CT150 SERIAL TOUCH MONITOR SLIMLINE BEZEL			
CAD FORMAT		SHEET 1 OF 1	
SIZE	DOCUMENT NO.	REV	REV
C	11-71315-227-01	I	I

4

3

2

1

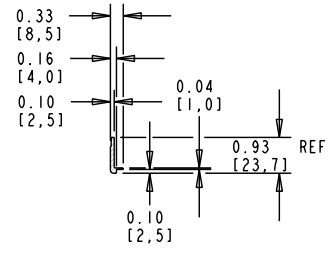
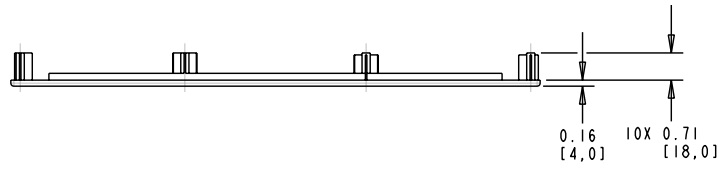

SECTION B-B

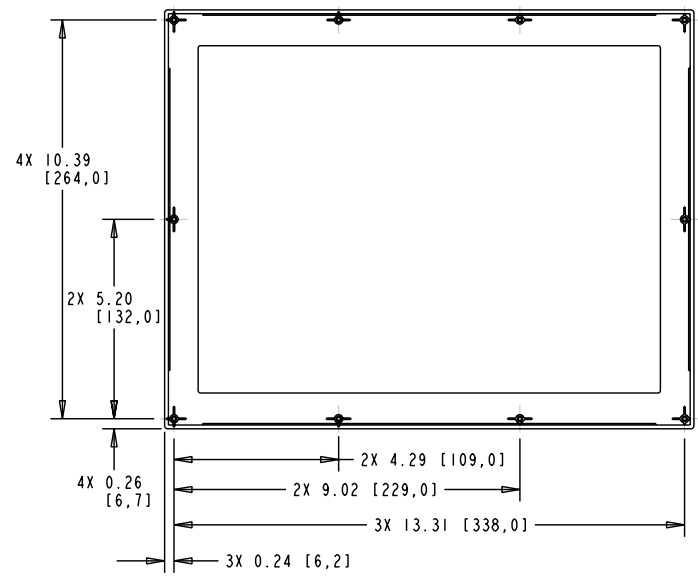
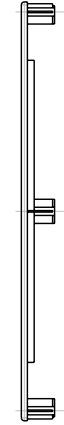
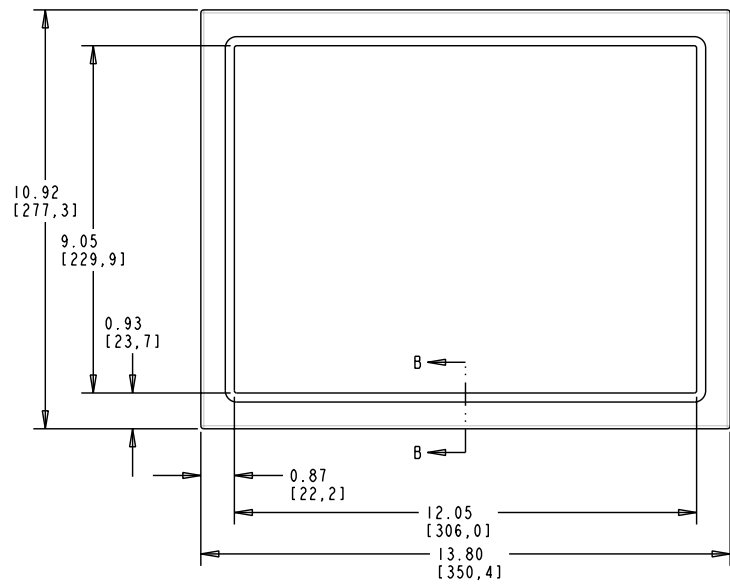
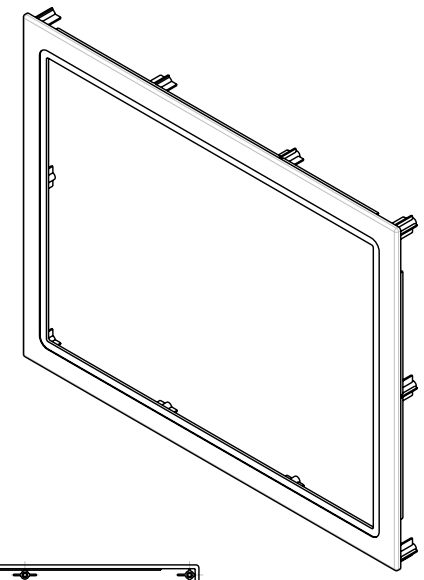

MicroTouch
www.CT150monitor.com

UNITS	INCHES [MM]
TOLERANCES UNLESS OTHERWISE SPECIFIED	
.X	±0.1
.XX	±0.01
.XXX	±0.005
ANGLES	±0.5°
THIRD ANGLE PROJECTION	
DO NOT SCALE DRAWING	
SCALE	1 = 1

3M 3M TOUCH SYSTEMS
METHUEN, MA
USA
© COPYRIGHT 2003
THIS DOCUMENT IS COPYRIGHTED PROPERTY OF THE 3M COMPANY AND MAY NOT BE REPRODUCED WITHOUT 3M WRITTEN PERMISSION OR USED OR DISCLOSED FOR OTHER THAN 3M AUTHORIZED PURPOSES.

REV	INITIAL RELEASE PER ECO XXXXXX	XX/XX/XX	XX
REV	CHANGE NOTICE	DATE	DWG
TITLE			
CT150 SLIMLINE BEZEL			
CAD FORMAT	SHEET		1 OF 1
SIZE	DOCUMENT NO.	REV	REV 1

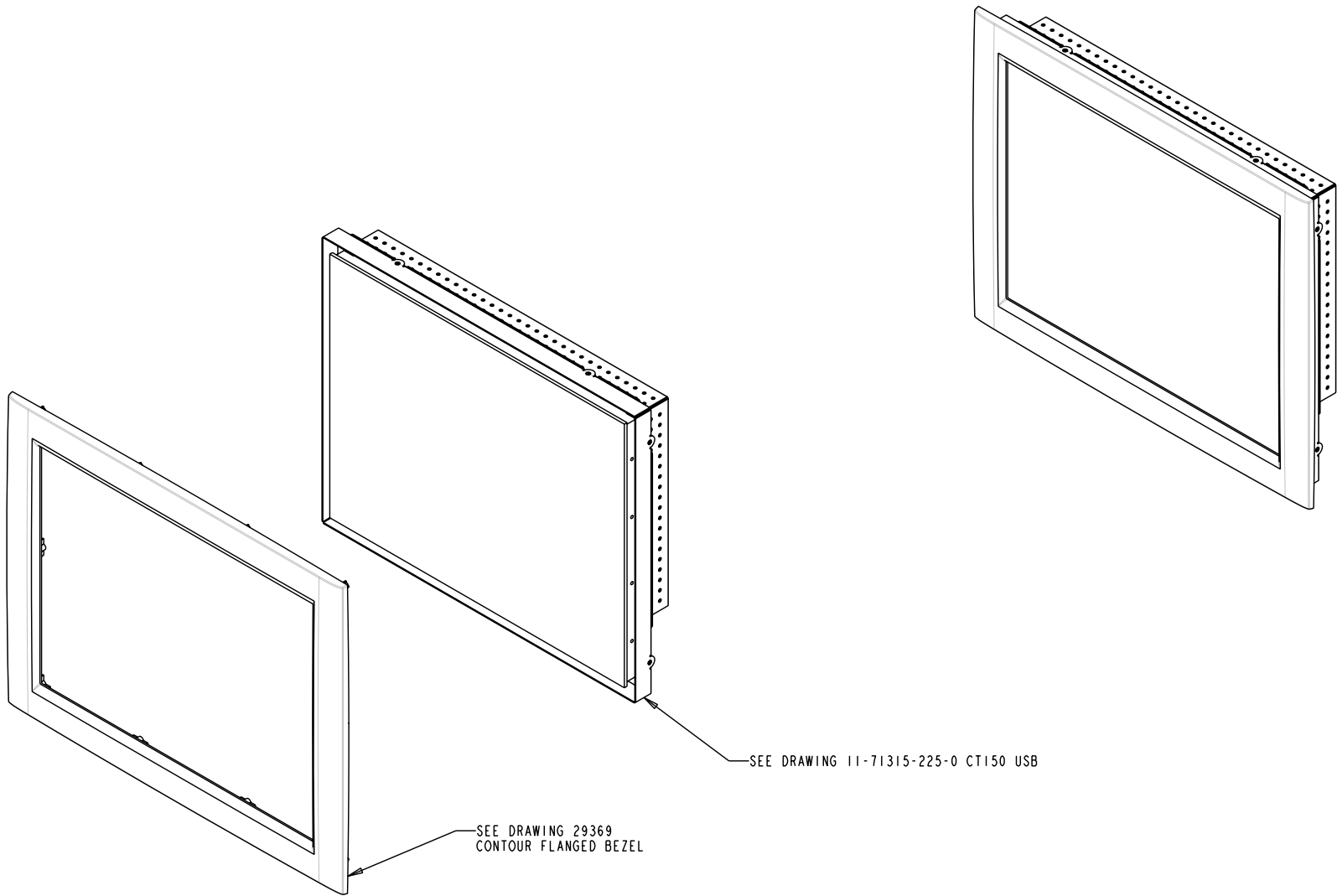

SEE DRAWING 11-71315-225-0 CT150 USB

SEE DRAWING 29369
CONTOUR FLANGED BEZEL

MicroTouch
www.CT150monitor.com

UNITS	INCHES [MM]
TOLERANCES UNLESS OTHERWISE SPECIFIED	
.X	±0.1
.XX	±0.01
.XXX	±0.005
ANGLES	±0.5°
THIRD ANGLE PROJECTION	
DO NOT SCALE DRAWING	
SCALE	1 = 1

3M 3M TOUCH SYSTEMS
METHUEN, MA
USA
© COPYRIGHT 2003
THIS DOCUMENT IS COPYRIGHTED PROPERTY OF
THE 3M COMPANY AND MAY NOT BE REPRODUCED
WITHOUT 3M WRITTEN PERMISSION OR USED OR
DISCLOSED FOR OTHER THAN 3M AUTHORIZED
PURPOSES.

REV	INITIAL RELEASE PER ECO XXXXXX	XX/XX/XX	XX
REV	CHANGE NOTICE	DATE	DWG
TITLE			
CT150 USB TOUCH MONITOR CONTOUR FLANGED BEZEL			
CAD FORMAT		SHEET 1 OF 1	
SIZE	DOCUMENT NO.	REV	
C	1-71315-225-03	REV I	

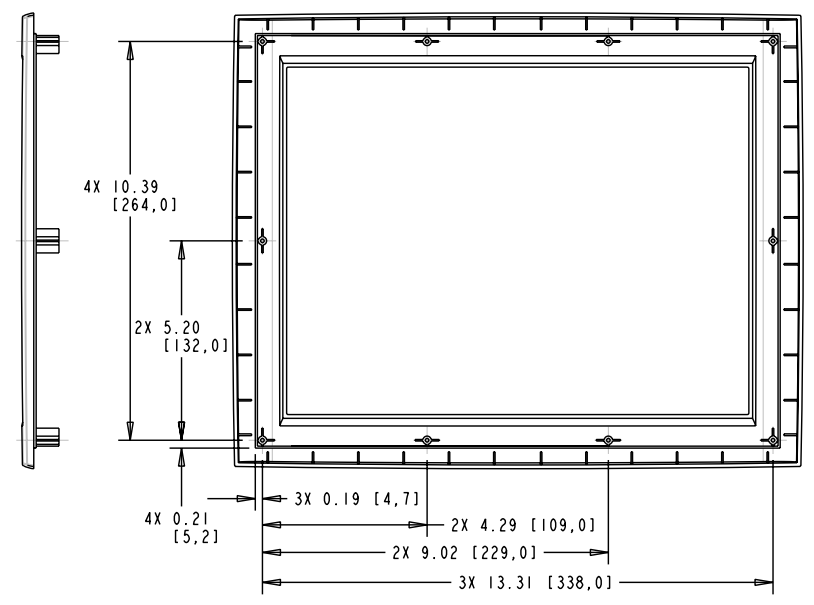
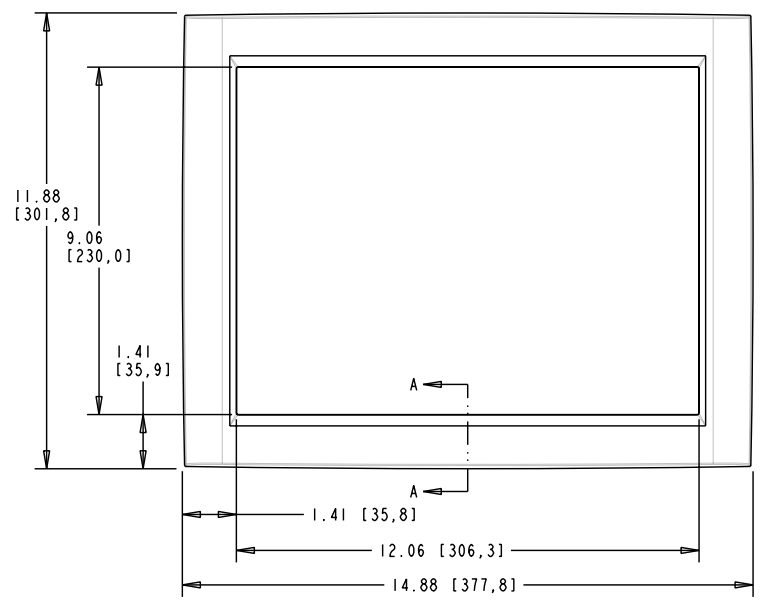
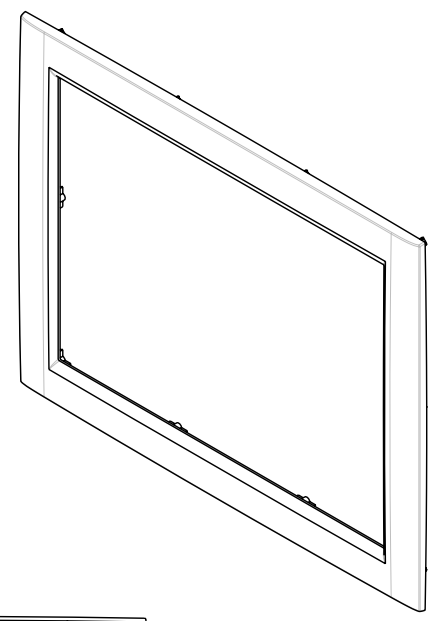
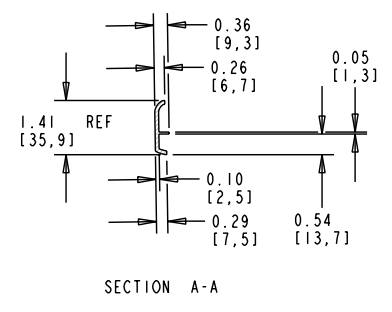
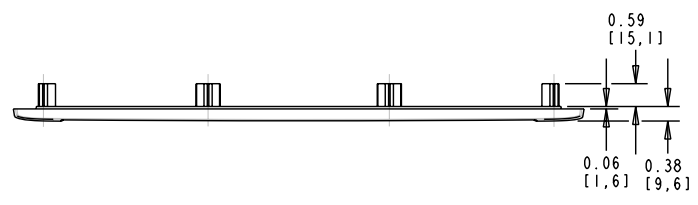

MicroTouch
www.CT150monitor.com

UNITS	INCHES [MM]
TOLERANCES UNLESS OTHERWISE SPECIFIED	
.X	± 0.1
.XX	± 0.01
.XXX	± 0.005
ANGLES	± 0.5°
THIRD ANGLE PROJECTION	
DO NOT SCALE DRAWING	
SCALE	1 = 1

3M 3M TOUCH SYSTEMS
METHUEN, MA
USA
© COPYRIGHT 2003
THIS DOCUMENT IS COPYRIGHTED PROPERTY OF THE 3M COMPANY AND MAY NOT BE REPRODUCED WITHOUT 3M WRITTEN PERMISSION OR USED OR DISCLOSED FOR OTHER THAN 3M AUTHORIZED PURPOSES.

REV	INITIAL RELEASE PER ECO XXXXXX	XX/XX/XX	XX
REV	CHANGE NOTICE	DATE	DWG
TITLE			
CT150 CONTOURED FLANGED BEZEL			
CAD FORMAT	SHEET		1 OF 1
SIZE	DOCUMENT NO.	REV	
C	29369	REV I	

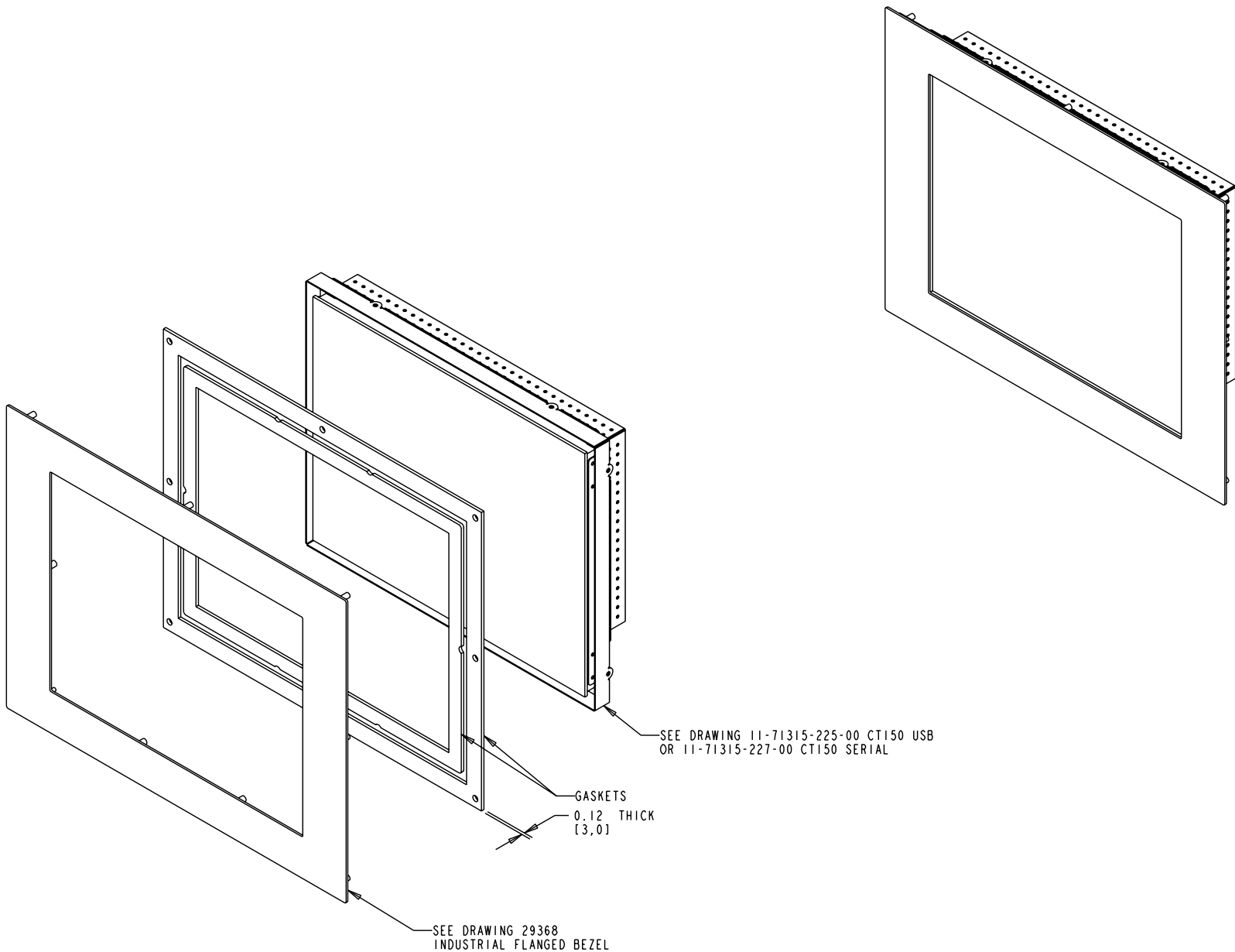

MicroTouch
www.CT150monitor.com

UNITS	INCHES [MM]
TOLERANCES UNLESS OTHERWISE SPECIFIED	
.X	±0.1
.XX	±0.01
.XXX	±0.005
ANGLES	±0.5°
THIRD ANGLE PROJECTION	
DO NOT SCALE DRAWING	
SCALE	1 = 1

3M 3M TOUCH SYSTEMS
METHUEN, MA
USA

© COPYRIGHT 2003
THIS DOCUMENT IS COPYRIGHTED PROPERTY OF THE 3M COMPANY AND MAY NOT BE REPRODUCED WITHOUT 3M WRITTEN PERMISSION OR USED OR DISCLOSED FOR OTHER THAN 3M AUTHORIZED PURPOSES.

REV	INITIAL RELEASE PER ECO XXXXXX	XX/XX/XX	XX
REV	CHANGE NOTICE	DATE	DRW
TITLE			
CT150 TOUCH MONITOR INDUSTRIAL BEZEL			
CAD FORMAT	SHEET		1 OF 1
SIZE	DOCUMENT NO.	REV	REV 1

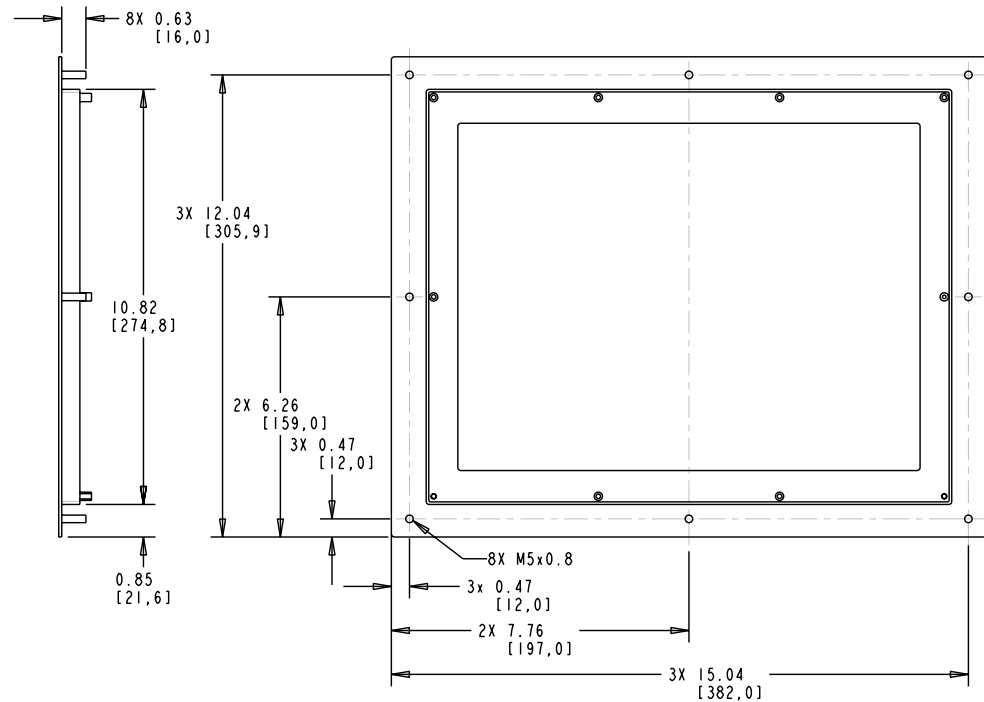
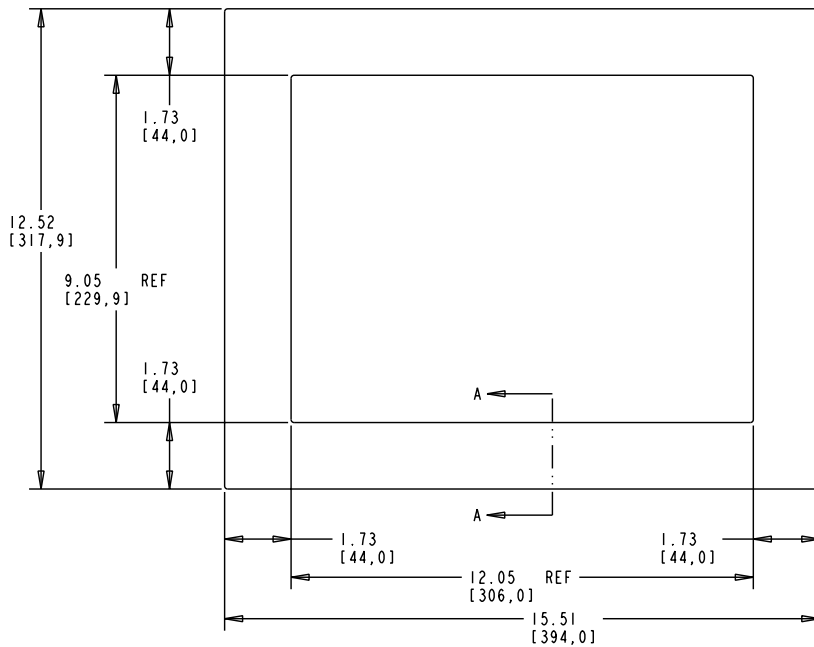
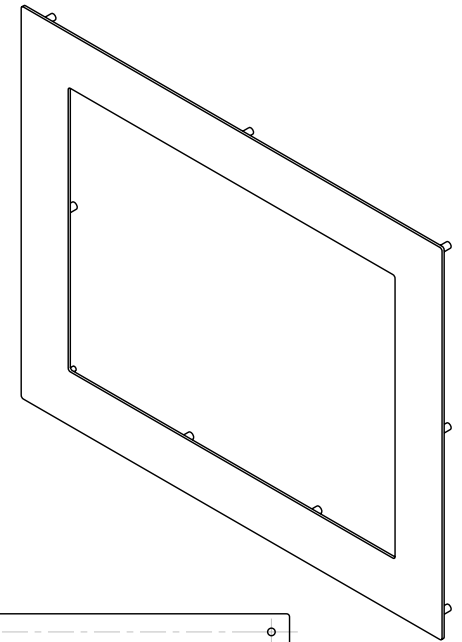
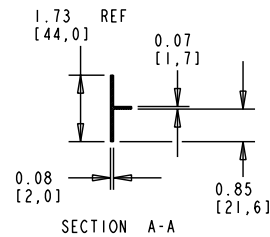
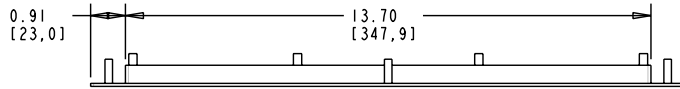

MicroTouch
www.CT150monitor.com

UNITS	INCHES [MM]
TOLERANCES UNLESS OTHERWISE SPECIFIED	
.X	±0.1
.XX	±0.01
.XXX	±0.005
ANGLES	±0.5°
THIRD ANGLE PROJECTION	
DO NOT SCALE DRAWING	
SCALE	1 = 1

3M 3M TOUCH SYSTEMS
METHUEN, MA
USA
© COPYRIGHT 2003
THIS DOCUMENT IS COPYRIGHTED PROPERTY OF THE 3M COMPANY AND MAY NOT BE REPRODUCED WITHOUT 3M WRITTEN PERMISSION OR USED OR DISCLOSED FOR OTHER THAN 3M AUTHORIZED PURPOSES.

REV	INITIAL RELEASE PER ECO XXXXXX	XX/XX/XX	XX
REV	CHANGE NOTICE	DATE	DWG
TITLE			
CT150 INDUSTRIAL FLANGED BEZEL			
CAD FORMAT	SHEET 1 OF 1		
SIZE	DOCUMENT NO.	REV	
C	29368	REV I	

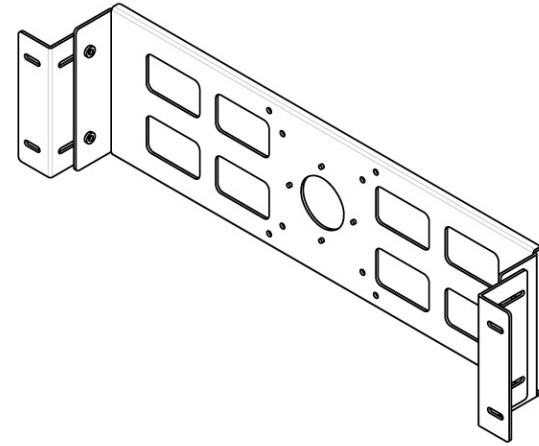
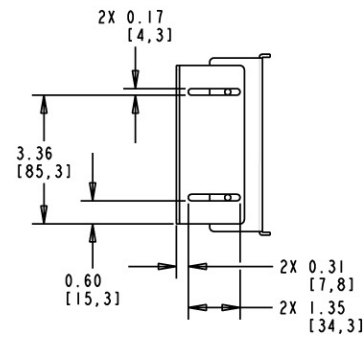
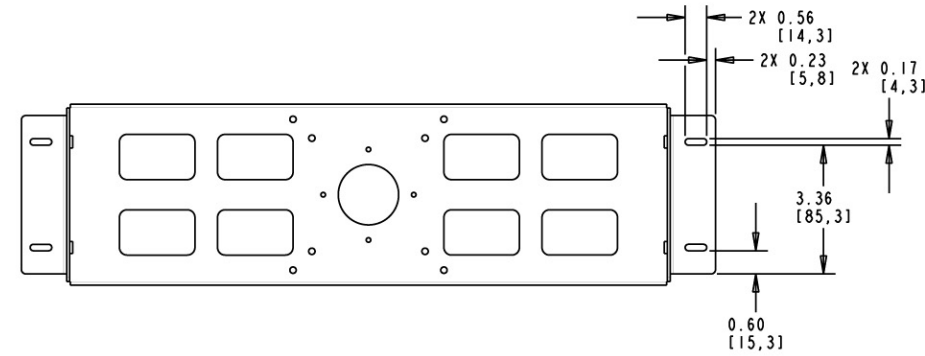
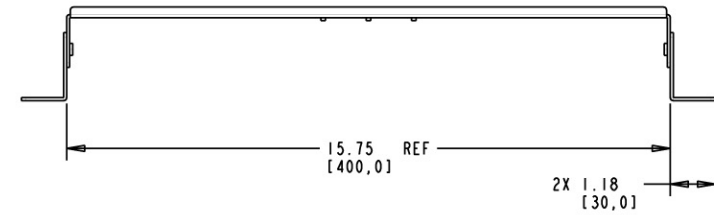

MicroTouch
www.CT150monitor.com

UNITS INCHES [MM]		3M 3M TOUCH SYSTEMS METHUEN, MA USA <small>© COPYRIGHT 2003 THIS DOCUMENT IS COPYRIGHTED PROPERTY OF THE 3M COMPANY AND MAY NOT BE REPRODUCED WITHOUT 3M WRITTEN PERMISSION OR USED OR DISCLOSED FOR OTHER THAN 3M AUTHORIZED PURPOSES.</small>	REV INITIAL RELEASE PER ECO XXXXXX		XX/XX/XX	
TOLERANCES UNLESS OTHERWISE SPECIFIED			REV CHANGE NOTICE		DATE	DWG
.X ±0.1			TITLE			
.XX ±0.01			HEAVY-DUTY MOUNTING BRACKET			
.XXX ±0.005						
ANGLES ±0.5°		THIRD ANGLE PROJECTION		CAD FORMAT		
DO NOT SCALE DRAWING		DRAWN		SHEET 1 OF 1		
SCALE 1 = 1		SIZE C		DOCUMENT NO. 30113		
				REV I		

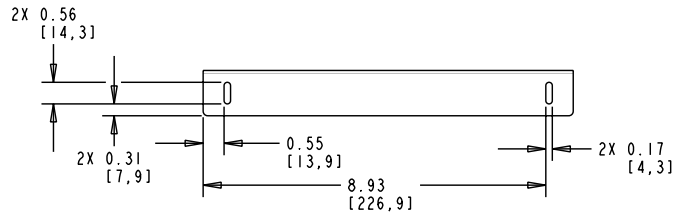
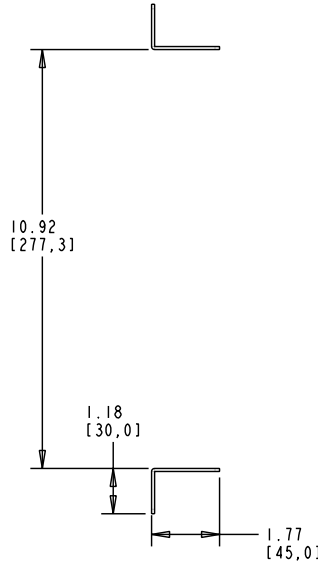
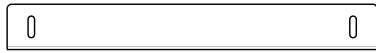
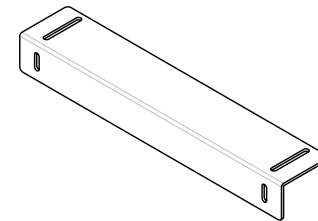
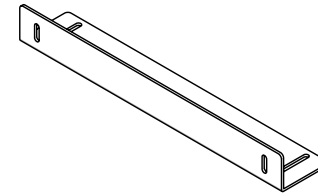
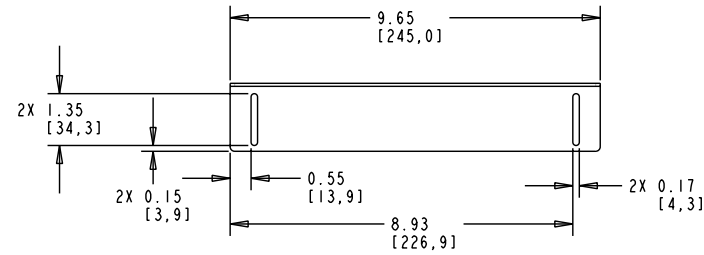

MicroTouch
www.CT150monitor.com

UNITS	INCHES [MM]
TOLERANCES UNLESS OTHERWISE SPECIFIED	
.X	±0.1
.XX	±0.01
.XXX	±0.005
ANGLES	±0.5°
THIRD ANGLE PROJECTION	
DO NOT SCALE DRAWING	
SCALE	1 = 1

3M 3M TOUCH SYSTEMS
METHUEN, MA
USA
© COPYRIGHT 2003
THIS DOCUMENT IS COPYRIGHTED PROPERTY OF THE 3M COMPANY AND MAY NOT BE REPRODUCED WITHOUT 3M WRITTEN PERMISSION OR USED OR DISCLOSED FOR OTHER THAN 3M AUTHORIZED PURPOSES.

REV	INITIAL RELEASE PER ECO XXXXXX	XX/XX/XX	XX
REV	CHANGE NOTICE	DATE	DWG
TITLE			
MOUNTING BRACKET			
CAD FORMAT		SHEET 1 OF 1	
SIZE	DOCUMENT NO.	REV	REV 1
C			