



Chipsmall Limited consists of a professional team with an average of over 10 year of expertise in the distribution of electronic components. Based in Hongkong, we have already established firm and mutual-benefit business relationships with customers from,Europe,America and south Asia,supplying obsolete and hard-to-find components to meet their specific needs.

With the principle of “Quality Parts,Customers Priority,Honest Operation,and Considerate Service”,our business mainly focus on the distribution of electronic components. Line cards we deal with include Microchip,ALPS,ROHM,Xilinx,Pulse,ON,Everlight and Freescale. Main products comprise IC,Modules,Potentiometer,IC Socket,Relay,Connector.Our parts cover such applications as commercial,industrial, and automotives areas.

We are looking forward to setting up business relationship with you and hope to provide you with the best service and solution. Let us make a better world for our industry!



## Contact us

Tel: +86-755-8981 8866 Fax: +86-755-8427 6832

Email & Skype: info@chipsmall.com Web: www.chipsmall.com

Address: A1208, Overseas Decoration Building, #122 Zhenhua RD., Futian, Shenzhen, China



# ELR W 3/9-400/FLK/PLC-MS 9

# ELR W 3/9-500/FLK/PLC-MS 9

## Electronic Reversing-Load Relay for 3-Phase Networks With Flat-Ribbon Cable Connector and Motor Protection Relay



Data Sheet

01/2005

## Features

### Electronic Reversing-Load Relay

ELR W 3/9... electronic reversing-load relays are the practical and user-friendly further development of electronic load relays for 3-phase networks.

These components feature high switching frequencies, virtually unlimited service life, no spark interference, and completely silent switching at zero voltage crossing. The compact, DIN rail-mountable modules meet all the requirements of an electronic reversing contactor circuit that has been designed specifically for industrial applications. Both the interlocking of control inputs and the complete wiring of the load contacts are incorporated in the device. Costly locking switches and contact wiring are thus a thing of the past.

Cabling has been reduced to an absolute minimum. Only the following must be applied:

- Control voltage, supply voltage input and output
- 3-phase load

The status is clearly indicated by separate LEDs for "right rotation", "left rotation", "operating voltage" or "impermissible control".

A short circuit between two phases at the moment of switching is prevented by the integrated delay between the control pulse and the load control.

RCV protective circuits on the output side reduce voltage peaks that occur in the load circuit to a safe level and prevent damage to the output electronics.

### Version With Flat-Ribbon Cable Connector and Motor Protection Relay

ELR W 3/9-.../FLK/PLC-MS 9 are also equipped with a motor protection relay (MS 9). The nominal current of the MS 9 can be preselected linearly in the range from 6 A - 9 A.

If the nominal current is exceeded due to overload or phase failure, the MS 9 disconnects the electronic load relay via alarm contacts. The error is indicated via an LED and also provided as a 24 V signal.

In automatic mode, the ELR is automatically reactivated once the integrated bimetals have cooled down. In manual mode, a reset must be carried out manually.

An integrated test function enables the thermal trigger mechanism to be simulated and thus permits the wiring to be checked before startup.



In accordance with DIN VDE 0110 and DIN VDE 0636, a conductor cross section of 1.5 mm<sup>2</sup> (16 AWG), which must be fitted with one fuse each (10 A slow-blow as mains protection), is required to connect the electronic load relay to the 3-phase network.

## Technical Data

Input Data (Input)	
Operating voltage	24 V DC +25%; -20% <sup>1</sup>
Maximum current consumption	40 mA
Control voltage right/left	24 V DC +25%; -20% <sup>1</sup>
Input current right/left	6 mA, approximately
Right rotation/left rotation switchover time (switch-on time)	20 ms
Input wiring	LED, diode for protection against polarity reversal, surge protection

<sup>1</sup> The operating voltage and control voltage inputs must be operated with power supply modules according to DIN 19240 (maximum 5% residual ripple). To prevent the inductive or capacitive coupling of disturbing pulses in long control cables, we recommend the use of shielded cables.

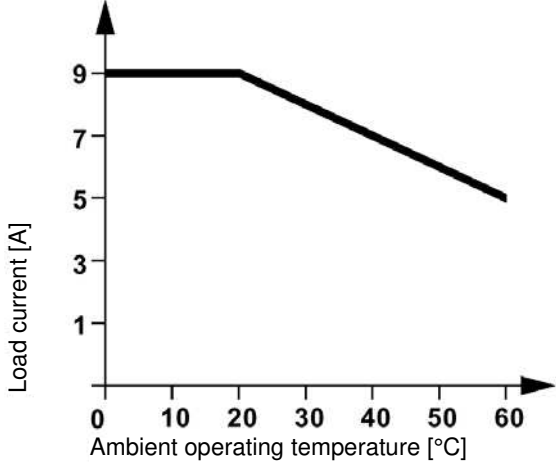
Output Data (Output)	ELR W 3/9-400/FLK/PLC-MS 9	ELR W 3/9-500/FLK/PLC-MS 9
Operating voltage (conductor voltage) 50 Hz/60 Hz	400 V AC	500 V AC
Operating voltage range	110 V AC - 440 V AC	110 V AC - 550 V AC
Reverse voltage	1000 V	1200 V
Maximum continuous load current	3 x 9 A	
Load current depending on the ambient operating temperature Operating time: 100% operating factor	 <p>The graph plots Load current [A] on the y-axis (0 to 9) against Ambient operating temperature [°C] on the x-axis (0 to 60). A horizontal line is drawn at 9 A from 0°C to 20°C. From 20°C to 60°C, the current decreases linearly, reaching 5 A at 60°C.</p>	
	<p>Figure 1 Load current depending on the ambient operating temperature</p>	

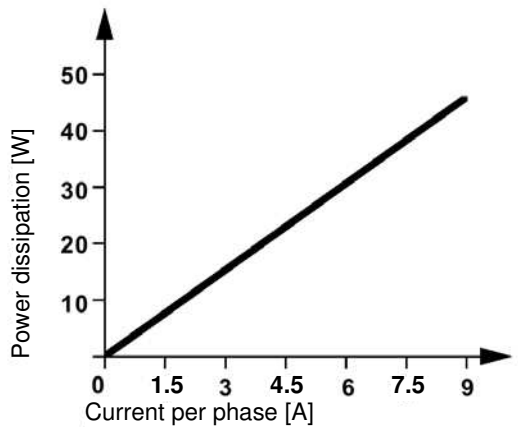
Output Data (Output) (Continued)	ELR W 3/9-400/FLK/PLC-MS 9	ELR W 3/9-500/FLK/PLC-MS 9
Power dissipation depending on the load current Operating time: 100% operating factor	 <p>Figure 2 Power dissipation depending on the load current</p>	
Surge current	230 A (t = 10 ms)	
Minimum load current	150 mA	
Residual voltage at $I_N$	1.7 V, typical	
Residual current in the OFF state	6 mA, typical	
Reversing frequency right rotation/left rotation ( $\cos \varphi = 0.5$ )	10 Hz, maximum	
Output wiring	RCV circuit, red LED (error message)	
Motor protection relay	Can be set from 6 A to 9 A (additional ranges available on request)	

General Data	
Housing dimensions (length x width x height)	142 mm x 62 mm x 115 mm (5.591 x 2.441 x 4.528 in.)
Insulating housing version	Polycarbonate (PC), color: green
Test voltage I/O	2.5 kV <sub>rms</sub>
Ambient operating temperature range	-20°C to +60°C (-4°F to +140°F)
Standards/specifications	EN 61000-4-4/DIN EN 61000-4-4/VDE 0847-4-4; EN 61000-4-5/DIN EN 61000-4-5/VDE 0847-4-5; IEC 60664/IEC 60664 A/DIN VDE 0110, basic insulation
Degree of protection according to IEC 60529/EN 60529/DIN VDE 0470-1	IP20
Mounting position	Vertical (DIN rail horizontal)
Mounting	Can be mounted with spacing $\geq 20$ mm (0.787 in.)



### Connection Data

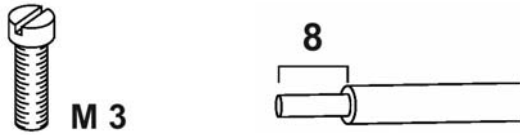
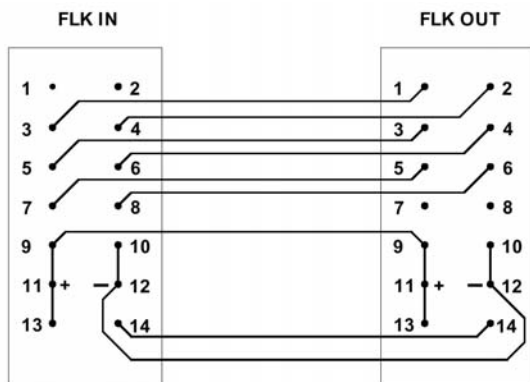

Figure 3 Connection data

The following cable cross sections can be connected:

Solid [mm <sup>2</sup> ]	Stranded [mm <sup>2</sup> ]	AWG	Stripping Length L [mm]
0.2 - 6	0.2 - 4	25 - 10	8 mm (0.31 in.)

### Pin Assignment of the Flat-Ribbon Cable Connector



For the ELR W 3/9-400/FLK/PLC-MS 9 module, no additional devices may be connected to the unused "operating voltage" (24 V/0 V) connections.

The supply voltage, which is connected via the flat-ribbon cable, is suitable for a maximum total current of 2 A.

Figure 4 Pin assignment

- Pin 1: "RIGHT" control
- Pin 2: "LEFT" control
- Pin 9/11/13: +24 V
- Pin 10/12: -GND
- Pin 14: Overload alarm (for ELR W 3/9-400/FLK/PLC-MS 9)

### Block Diagram

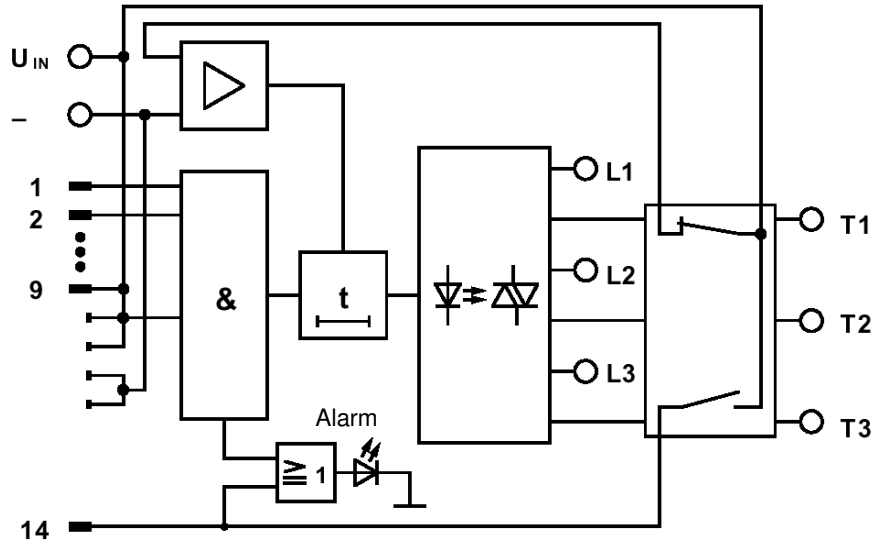

Figure 5 Block diagram

## Ordering Data

Description	Order Designation	Order No.
Electronic reversing-load relay for directly controlling devices in a 3-phase network, with LED, protective circuit, flat-ribbon cable connector, and motor protection relay.	ELR W 3/9-400/FLK/PLC-MS 9	29 64 20 9
	ELR W 3/9-500/FLK/PLC-MS 9	29 64 75 9
Motor protection relay	MS 9	29 41 89 5
For a suitable 14-pos. cable (FLK 14/ EZ-DR/... KONFEK), see INTERFACE catalog.		
For marking systems and assembly material, see CLIPLINE catalog.		



Make sure you always use the latest documentation.  
It can be downloaded from [www.download.phoenixcontact.com](http://www.download.phoenixcontact.com).

PHOENIX CONTACT GmbH & Co. KG  
Flachmarktstr. 8  
32825 Blomberg  
Germany



+49 - 52 35 - 30 0



+49 - 52 35 - 34 12 00



[www.phoenixcontact.com](http://www.phoenixcontact.com)



Worldwide Locations:

[www.phoenixcontact.com/salesnetwork](http://www.phoenixcontact.com/salesnetwork)