



Chipsmall Limited consists of a professional team with an average of over 10 year of expertise in the distribution of electronic components. Based in Hongkong, we have already established firm and mutual-benefit business relationships with customers from,Europe,America and south Asia,supplying obsolete and hard-to-find components to meet their specific needs.

With the principle of “Quality Parts,Customers Priority,Honest Operation,and Considerate Service”,our business mainly focus on the distribution of electronic components. Line cards we deal with include Microchip,ALPS,ROHM,Xilinx,Pulse,ON,Everlight and Freescale. Main products comprise IC,Modules,Potentiometer,IC Socket,Relay,Connector.Our parts cover such applications as commercial,industrial, and automotives areas.

We are looking forward to setting up business relationship with you and hope to provide you with the best service and solution. Let us make a better world for our industry!



Contact us

Tel: +86-755-8981 8866 Fax: +86-755-8427 6832

Email & Skype: info@chipsmall.com Web: www.chipsmall.com

Address: A1208, Overseas Decoration Building, #122 Zhenhua RD., Futian, Shenzhen, China



Electronic housing - CM 50-LG/H 12,5/BO BK - 2943592

Please be informed that the data shown in this PDF Document is generated from our Online Catalog. Please find the complete data in the user's documentation. Our General Terms of Use for Downloads are valid (<http://phoenixcontact.com/download>)



Complete housing, length: 102 mm, with vents, Cross connection: without bus connector, color: black, width: 50 mm, height: 115.5 mm, number of positions cross connector: not relevant

Why buy this product

- ✓ Rugged housing technology
- ✓ Flexible accommodation of different connection elements (from high-position connectors to electronic PCBs)
- ✓ Easy snap-on mounting on symmetrical DIN rails according to EN 60715
- ✓ Shock and contamination-proof accommodation of electronic components

Key Commercial Data

Packing unit	5 STK
GTIN	 4 017918 081195
GTIN	4017918081195

Technical data

General

Housing type	Complete housing
Housing material	Polycarbonate fiber reinforced
Color (RAL)	black (9005)

Ambient conditions

Ambient temperature (operation)	-40 °C ... 105 °C (depending on power dissipation)
---------------------------------	--

Dimensions

Length	102 mm
Constructional height	115.5 mm
Width	50 mm
Depth	102 mm

Technical data

Electronic housing - CM 50-LG/H 12,5/BO BK - 2943592

Technical data

Technical data

Power dissipation without gap	25 W
Power dissipation with 20 mm gap	38.3 W

Standards and Regulations

Flammability rating according to UL 94	V0
--	----

Environmental Product Compliance

China RoHS	Environmentally friendly use period: unlimited = EFUP-e
	No hazardous substances above threshold values

Drawings

Dimensional drawing

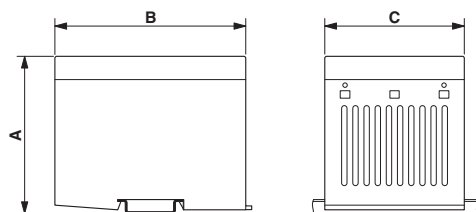

Dimension A: 115.5 mm; dimension B: 102 mm; dimension C: 50 mm

Dimensional drawing

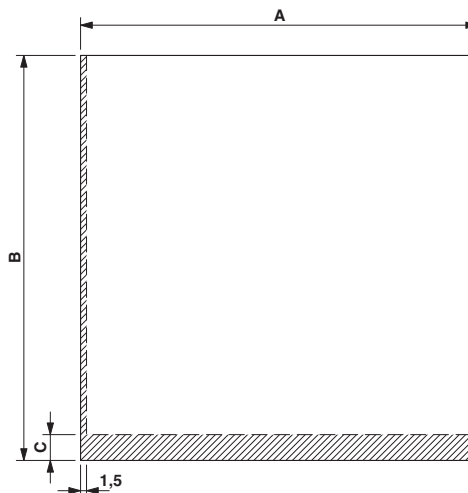

PCB 1, 7: Dimension A: 47.5 mm; B: 102.0 mm; C: 6.5 mm
 PCB 8, 13: Dimension A: 100.0 mm; B: 102.0 mm; C: 6.5 mm
 PCB 10: Dimension A: 100.0 mm; B: 92.3 mm; C: 0 mm

Electronic housing - CM 50-LG/H 12,5/BO BK - 2943592

Schematic diagram

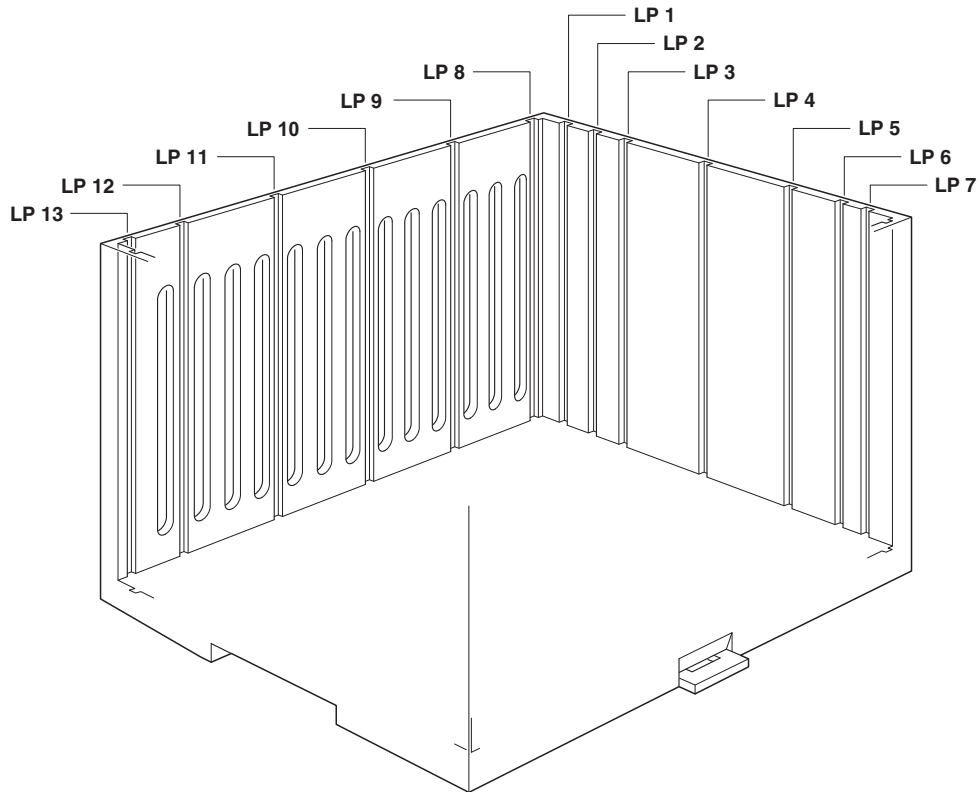

Phoenix Contact 2018 © - all rights reserved
<http://www.phoenixcontact.com>

PHOENIX CONTACT GmbH & Co. KG
Flachsmarktstr. 8
32825 Blomberg
Germany
Tel. +49 5235 300
Fax +49 5235 3 41200
<http://www.phoenixcontact.com>