



Chipsmall Limited consists of a professional team with an average of over 10 year of expertise in the distribution of electronic components. Based in Hongkong, we have already established firm and mutual-benefit business relationships with customers from,Europe,America and south Asia,supplying obsolete and hard-to-find components to meet their specific needs.

With the principle of “Quality Parts,Customers Priority,Honest Operation,and Considerate Service”,our business mainly focus on the distribution of electronic components. Line cards we deal with include Microchip,ALPS,ROHM,Xilinx,Pulse,ON,Everlight and Freescale. Main products comprise IC,Modules,Potentiometer,IC Socket,Relay,Connector.Our parts cover such applications as commercial,industrial, and automotives areas.

We are looking forward to setting up business relationship with you and hope to provide you with the best service and solution. Let us make a better world for our industry!



Contact us

Tel: +86-755-8981 8866 Fax: +86-755-8427 6832

Email & Skype: info@chipsmall.com Web: www.chipsmall.com

Address: A1208, Overseas Decoration Building, #122 Zhenhua RD., Futian, Shenzhen, China



Electronic housing - UMK- SE 11,25 - 2970002

Please be informed that the data shown in this PDF Document is generated from our Online Catalog. Please find the complete data in the user's documentation. Our General Terms of Use for Downloads are valid (<http://download.phoenixcontact.com>)

Universal module, comprising: Side element, 11.25 mm wide, with marker groove



The illustration shows a combination of versions UMK SE 11,25, UMK BE 11,25, - 22,5, -45 and UMK-FE

Why buy this product

- The modules can be marked using the marking grooves in the lateral element as well as with the Phoenix Contact PMB module marker, which is snapped into a bore hole (4 mm Ø) in the PCB
- Wide range of options for external conductor connection
- Fast assembly thanks to the plug-in module principle. The tight engagement of the individual elements ensures that they are securely connected.
- Due to the universal foot, the modules can be snapped onto standard EN DIN rails
- The mounting flange supports direct wall mounting



Key commercial data

| | |
|------------------------|---|
| Packing unit | 1 |
| Minimum order quantity | 10 |
| Catalog page | Page 648 (CC-2011) |
| GTIN |  4 017918 087531 |
| Custom tariff number | 85389099 |
| Country of origin | POLAND |

Technical data

General

| | |
|------------------|------------|
| Housing type | Side cover |
| Housing material | Polyamide |
| Color | green |

Technical data

| | |
|---|----|
| Inflammability class according to UL 94 | V2 |
|---|----|

Electronic housing - UMK- SE 11,25 - 2970002

Classifications

eclass

| | |
|------------|----------|
| eCl@ss 4.0 | 27180401 |
| eCl@ss 4.1 | 27180401 |
| eCl@ss 5.0 | 27180506 |
| eCl@ss 5.1 | 27180506 |
| eCl@ss 6.0 | 27180802 |
| eCl@ss 7.0 | 27182701 |

etim

| | |
|----------|----------|
| ETIM 2.0 | EC001031 |
| ETIM 3.0 | EC001031 |
| ETIM 4.0 | EC001031 |
| ETIM 5.0 | EC002779 |

unspsc

| | |
|---------------|----------|
| UNSPSC 6.01 | 31261501 |
| UNSPSC 7.0901 | 31261501 |
| UNSPSC 11 | 31261501 |
| UNSPSC 12.01 | 31261501 |
| UNSPSC 13.2 | 31261501 |

Approvals

Approvals

Approvals

UL Recognized

Ex Approvals

Approvals submitted

Approval details

| |
|---|
| UL Recognized  |
|---|

Drawings

Electronic housing - UMK- SE 11,25 - 2970002

Dimensioned drawing

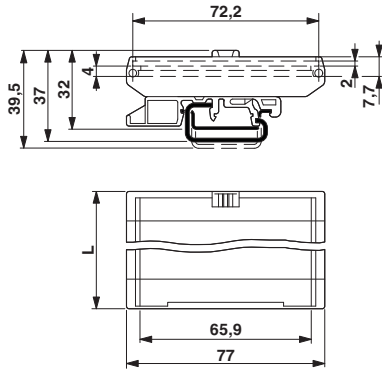

© Phoenix Contact 2012 - all rights reserved
<http://www.phoenixcontact.com>