



Chipsmall Limited consists of a professional team with an average of over 10 year of expertise in the distribution of electronic components. Based in Hongkong, we have already established firm and mutual-benefit business relationships with customers from,Europe,America and south Asia,supplying obsolete and hard-to-find components to meet their specific needs.

With the principle of “Quality Parts,Customers Priority,Honest Operation,and Considerate Service”,our business mainly focus on the distribution of electronic components. Line cards we deal with include Microchip,ALPS,ROHM,Xilinx,Pulse,ON,Everlight and Freescale. Main products comprise IC,Modules,Potentiometer,IC Socket,Relay,Connector.Our parts cover such applications as commercial,industrial, and automotives areas.

We are looking forward to setting up business relationship with you and hope to provide you with the best service and solution. Let us make a better world for our industry!



Contact us

Tel: +86-755-8981 8866 Fax: +86-755-8427 6832

Email & Skype: info@chipsmall.com Web: www.chipsmall.com

Address: A1208, Overseas Decoration Building, #122 Zhenhua RD., Futian, Shenzhen, China



Electronic housing - UMK- BE 11,25 - 2971535

Please be informed that the data shown in this PDF Document is generated from our Online Catalog. Please find the complete data in the user's documentation. Our General Terms of Use for Downloads are valid (<http://download.phoenixcontact.com>)

Electronic board base, plug-in module base element



Why buy this product

- The modules can be marked using the marking grooves in the lateral element as well as with the Phoenix Contact PMB module marker, which is snapped into a bore hole (4 mm Ø) in the PCB
- Fast assembly thanks to the plug-in module principle. The tight engagement of the individual elements ensures that they are securely connected.
- Wide range of options for external conductor connection
- The mounting flange supports direct wall mounting
- Due to the universal foot, the modules can be snapped onto standard EN DIN rails



Key commercial data

Packing unit	1
Minimum order quantity	10
Catalog page	Page 648 (CC-2011)
GTIN	 4 017918 088392
Custom tariff number	85472000
Country of origin	POLAND

Technical data

General

Housing type	Panel mounting base
Housing material	Polyamide
Color	green

Dimensions / positions

Length	77 mm
Width	11.25 mm

Technical data

Ambient temperature (operation)	-40 °C ... 105 °C
---------------------------------	-------------------

Electronic housing - UMK- BE 11,25 - 2971535

Technical data

Technical data

Inflammability class according to UL 94	V2
---	----

Classifications

eclass

eCl@ss 4.0	27180401
eCl@ss 4.1	27180401
eCl@ss 5.0	27180506
eCl@ss 5.1	27180506
eCl@ss 6.0	27180802
eCl@ss 7.0	27182701

etim

ETIM 2.0	EC001031
ETIM 3.0	EC001031
ETIM 4.0	EC001031
ETIM 5.0	EC000721

unspsc

UNSPSC 6.01	31261501
UNSPSC 7.0901	31261501
UNSPSC 11	31261501
UNSPSC 12.01	31261501
UNSPSC 13.2	31261501

Approvals

Approvals

Approvals

UL Recognized

Ex Approvals

Approvals submitted

Approval details

UL Recognized

Electronic housing - UMK- BE 11,25 - 2971535

Accessories

Accessories

Assembly

Mounting flange - UMK-BF - 2976077



Mounting flange, for mounting directly on the wall

Electronic housing - UMK-BE 45 - 2970015



Electronic board base, plug-in module base element

Electronic housing - UMK-BE 22,5 - 2970028



Electronic board base, plug-in module base element

Foot element - UMK-FE - 2970031



Foot element, for mounting on DIN rail NS 32 or DIN rail NS 35/7.5, can be inserted between base and side element

Drawings

Electronic housing - UMK- BE 11,25 - 2971535

Dimensioned drawing

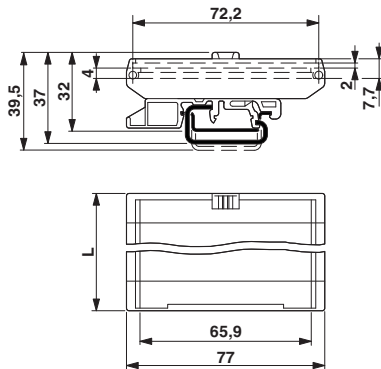

© Phoenix Contact 2012 - all rights reserved
<http://www.phoenixcontact.com>