



Chipsmall Limited consists of a professional team with an average of over 10 year of expertise in the distribution of electronic components. Based in Hongkong, we have already established firm and mutual-benefit business relationships with customers from,Europe,America and south Asia,supplying obsolete and hard-to-find components to meet their specific needs.

With the principle of “Quality Parts,Customers Priority,Honest Operation,and Considerate Service”,our business mainly focus on the distribution of electronic components. Line cards we deal with include Microchip,ALPS,ROHM,Xilinx,Pulse,ON,Everlight and Freescale. Main products comprise IC,Modules,Potentiometer,IC Socket,Relay,Connector.Our parts cover such applications as commercial,industrial, and automotives areas.

We are looking forward to setting up business relationship with you and hope to provide you with the best service and solution. Let us make a better world for our industry!



Contact us

Tel: +86-755-8981 8866 Fax: +86-755-8427 6832

Email & Skype: info@chipsmall.com Web: www.chipsmall.com

Address: A1208, Overseas Decoration Building, #122 Zhenhua RD., Futian, Shenzhen, China



PSR-...-24UC/URM/5X1/1X2

PL
EN ISO 13849

SIL
IEC 61508



Safe coupling relay

Data sheet
107846_en_01

© PHOENIX CONTACT 2018-04-03

1 Description

Intended Use

The safe coupling relay is used for power adaptation and electrical isolation in high and low-demand applications. The device couples digital signals from failsafe controllers. Alternatively, when used in combination with a suitable basic device the device provides additional output contacts. The coupling relay safely interrupts circuits.

Possible signal generators

- Failsafe controllers
- Safety relays

Contact type

- 5 undelayed enabling current paths
- 1 undelayed confirmation current path

The enabling current paths drop out without delay according to stop category 0 (EN 60204-1).

Control

- Single or two channel
- Automatic start

Achievable safety integrity

- Suitable up to category 1, PL c (EN ISO 13849-1), SILCL 1 (EN 62061), SIL 1 (IEC 61508)

Additional features

- Safe readback due to force-guided signal contact in accordance with EN 50205
- Easy proof test according to IEC 61508 due to forcibly guided signal contact
- Option of screw or spring-cage terminal blocks for plug-in
- 22.5 mm housing width

Approvals



WARNING: Risk of electric shock

Observe the safety regulations and installation notes in the corresponding section.



Make sure you always use the latest documentation.

It can be downloaded from the product at phoenixcontact.net/products.



This document is valid for the products listed in the "Ordering data".

This document meets the same requirements as the original operating instructions with respect to the contents.

2	Table of contents	
1	Description	1
2	Table of contents	2
3	Ordering data	3
4	Technical data	3
5	Notes regarding documentation	7
6	Safety regulations and installation notes.....	8
7	Function description	10
8	Function and time diagrams	10
9	Basic circuit diagram	11
10	Load curve.....	11
11	Operating and indication elements	12
12	Mounting and removing	13
13	Wiring	13
14	Startup.....	14
15	Calculating the power dissipation	14
16	Proof test	14
17	Application examples	15
18	Attachment	17

3 Ordering data

Description	Type	Order No.	Pcs./Pkt.
Safe coupling relay with force-guided contacts, 5 N/O contacts, 1 N/C contact, plug-in screw terminal block, width: 22.5 mm	PSR-SCP- 24UC/URM/5X1/1X2	2981952	1
Safe coupling relay with force-guided contacts, 5 N/O contacts, 1 N/C contact, plug-in spring-cage terminal block, width: 22.5 mm	PSR-SPP- 24UC/URM/5X1/1X2	2981965	1

4 Technical data

Hardware/firmware version	
HW/FW	≥ 04/--
The technical data and safety characteristics are valid as of the specified HW/FW version.	
Input data	
Rated control circuit supply voltage U_S	24 V AC/DC -15 % / +10 %
Rated control supply current I_S	typ. 47 mA
Inrush current	typ. 350 mA DC ($\Delta t < 1 \mu s$ at U_S) typ. 350 mA AC ($\Delta t = 2$ ms at U_S)
Power consumption at U_S	typ. 1.2 W
Typical starting time with U_S	typ. 20 ms (when controlled via A1)
Typical release time with U_S	typ. 20 ms (when controlled via A1)
Recovery time	< 500 ms
Maximum switching frequency	0.5 Hz
Operating voltage display	1 x green LED
Protective circuit	Surge protection Varistor
Output data	
Contact type	5 enabling current paths 1 confirmation current path
Contact material	AgSnO ₂
Minimum switching voltage	5 V AC/DC
Maximum switching voltage	230 V AC/DC (Observe the load curve)
Limiting continuous current	6 A (N/O contact) 6 A (N/C contact)
Maximum inrush current	6 A
Inrush current, minimum	10 mA
Sq. Total current $I_{TH}^2 = I_1^2 + I_2^2 + \dots + I_N^2$	72 A ²

Output data

Interrupting rating (ohmic load) max.	144 W (N/O contact, 24 V DC, $\tau = 0$ ms) 288 W (N/O contact, 48 V DC, $\tau = 0$ ms) 240 W (N/O contact, 60 V DC, $\tau = 0$ ms) 110 W (N/O contact, 110 V DC, $\tau = 0$ ms) 88 W (N/O contact, 220 V DC, $\tau = 0$ ms) 1380 VA (N/O contact, 230 V AC, $\tau = 0$ ms)
Maximum interrupting rating (inductive load)	42 W (N/O contact, 24 V DC, $\tau = 40$ ms) 42 W (N/O contact, 48 V DC, $\tau = 40$ ms) 42 W (N/O contact, 60 V DC, $\tau = 40$ ms) 42 W (N/O contact, 110 V DC, $\tau = 40$ ms) 42 W (N/O contact, 220 V DC, $\tau = 40$ ms)
Switching capacity	min. 50 mW
Mechanical service life	10×10^6 cycles
Switching capacity (360/h cycles)	4 A (24 V (DC13)) 4 A (250 V (AC15))
Switching capacity according to IEC 60947-5-1	3 A (24 V (DC13)) 3 A (250 V (AC15))
Output fuse	10 A gL/gG (N/O contact) 4 A gL/gG (N/O contact, for low-demand applications) 6 A gL/gG (N/C contact)

General data

Relay type	Electromechanical relay with forcibly guided contacts in accordance with EN 50205
Nominal operating mode	100% operating factor
Degree of protection	IP20
Min. degree of protection of inst. location	IP54
Mounting type	DIN rail mounting
Mounting position	vertical or horizontal
Weight	177.2 g
Type of housing	PBT yellow
Air clearances and creepage distances between the power circuits	DIN EN 50178
Rated insulation voltage	250 V
Rated surge voltage/insulation	4 kV / basic isolation (safe isolation, reinforced isolation and 6 kV between A1/A2, 53/54, 71/72 and 13/14, 23/24, 33/34, 43/44.) See "Insulation coordination"
Degree of pollution	2
Overvoltage category	III
Maximum power dissipation for nominal condition	37.36 W (at $U_B = 26.4$ V DC, $I_L^2 = 72$ A ²)
Note on power dissipation	See "Calculating the power dissipation"

Dimensions		
	Screw connection	Spring-cage connection
W x H x D	22.5 x 114.5 x 99 mm	22.5 x 114.5 x 112 mm
Connection data		
	Screw connection	Spring-cage connection
Conductor cross section, solid	0.2 mm ² ... 2.5 mm ²	0.2 mm ² ... 1.5 mm ²
Conductor cross section, flexible	0.2 mm ² ... 2.5 mm ²	0.2 mm ² ... 1.5 mm ²
Conductor cross section AWG/kcmil	24 ... 12	24 ... 16
Stripping length	7 mm	8 mm
Screw thread	M3	
Ambient conditions		
Ambient temperature (operation)	-20 °C ... 55 °C	
Ambient temperature (storage/transport)	-40 °C ... 70 °C	
Max. permissible relative humidity (operation)	75 % (on average, 85% infrequently, non-condensing)	
Max. permissible humidity (storage/transport)	75 % (on average, 85% infrequently, non-condensing)	
Maximum altitude	max. 2000 m (Above sea level)	
Information on operating height	See the "Using PSR devices at altitudes greater than 2000 m above sea level" section	
Shock	15g (In the event of stress caused by shock, contact reactions are possible for up to 2 ms.)	
Vibration (operation)	10 Hz ... 150 Hz, 2g (In the event of stress caused by vibration, contact reactions are possible for up to 1 ms.)	
Conformance/Approvals		
Conformance	CE-compliant	
The full EC Declaration of Conformity can be downloaded for the product at phoenixcontact.net/products .		
Approvals		
Safety data		
Stop category according to IEC 60204	0	

Safety parameters for IEC 61508 - High demand

Equipment type	Type A
HFT	0
SIL	1
PFH _D	1.00 x 10 ⁻⁷ (3 A AC15; 8760 switching cycles/year; 5 % of the total SIL) 1.35 x 10 ⁻⁷ (3 A DC13; 8760 switching cycles/year; 5 % of the total SIL) 1.56 x 10 ⁻⁷ (6 A AC1; 8760 switching cycles/year; 5% of the total SIL)
Demand rate	< 12 Months
Proof test interval	240 Months
Duration of use	240 Months

Safety parameters for IEC 61508 - Low demand

Equipment type	Type A
HFT	0
SIL	1
PFD _{avg}	4.05 x 10 ⁻³
Proof test interval	56 Months
Duration of use	240 Months

Safety characteristic data according to EN ISO 13849

Category	1
Performance level	c
Duration of use	240 Months

Safety parameters for EN 62061

SILCL	1
-------	---

5 Notes regarding documentation

5.1 Explanation of symbols used and signal words



This is the safety alert symbol. It is used to alert you to potential personal injury hazards. Obey all safety measures that follow this symbol to avoid possible injury or death.

There are three different categories of personal injury that are indicated with a signal word.

- DANGER** This indicates a hazardous situation which, if not avoided, will result in death or serious injury.
- WARNING** This indicates a hazardous situation which, if not avoided, could result in death or serious injury.
- CAUTION** This indicates a hazardous situation which, if not avoided, could result in minor or moderate injury.



This symbol together with the signal word **NOTE** and the accompanying text alert the reader to a situation which may cause damage or malfunction to the device, hardware/software, or surrounding property.



This symbol and the accompanying text provide the reader with additional information or refer to detailed sources of information.

5.2 Validity

This data sheet is valid for the described product(s) from the hardware/firmware version specified in the technical data.

5.3 Target group

This data sheet is therefore aimed at:

- Qualified personnel who plan and design safety equipment for machines and systems and are familiar with regulations governing occupational safety and accident prevention.
- Qualified personnel who install and operate safety equipment in machines and systems.

Qualified personnel:

Qualified personnel are people who, because of their education, experience, and instruction and their knowledge of relevant standards, regulations, accident prevention, and service conditions, have been authorized by those responsible for the safety of the system to carry out any required operations and who are able to recognize and avoid any possible dangers.

Requirements:

Knowledge of the following topics is required:

- Handling safety components
- Valid EMC regulations
- Valid regulations governing occupational safety and accident prevention

6 Safety regulations and installation notes



WARNING: Death, serious personal injury or damage to equipment

Depending on the application, incorrect handling of the device may pose serious risks for the user or cause damage to equipment.

- Observe all the safety notes and warning instructions provided in this chapter and elsewhere in this document.

General

- Observe the safety regulations of electrical engineering and industrial safety and liability associations.

Disregarding these safety regulations may result in death, serious personal injury or damage to equipment.

Direct/indirect contact

- Protection against direct and indirect contact according to VDE 0100 Part 410 must be ensured for all components connected to the system.

In the event of an error, parasitic voltages must not occur (single-fault tolerance).

Power supply units for 24 V supply

- Only use power supply units with safe isolation and SELV/PELV according to EN 50178/VDE 0160.
- Protect the 24 V area with a suitable external fuse.
- Make sure that the power supply unit is able to supply **four times** the nominal current of the external fuse, to ensure that it trips in the event of an error.
- Make sure that the output voltage of the voltage supply does not exceed 32 V even in the event of error.

Startup, mounting, and modifications

Startup, mounting, modifications, and upgrades may only be carried out by an electrically skilled person.

- Before working on the device, disconnect the power.
- Carry out wiring according to the application. Refer to the "Application examples" section for this.

Reliable operation is only ensured if the device is installed in housing protected from dust and humidity.

- Install the device in housing protected from dust and humidity (min. IP54).

In operation

During operation, parts of electrical switching devices carry hazardous voltages.

- Protective covers must not be removed when operating electrical switching devices.

For emergency stop applications, automatic startup of the machine can pose serious risks for the user.

- The machine must be prevented from restarting automatically by a higher-level controller.

Inductive loads can lead to welded relay contacts.

- Connect a suitable and effective protective circuit to inductive loads.
- Implement the protective circuit parallel to the load and not parallel to the switch contact.

Magnetic fields can influence the device. The magnetic field strength of the environment must not exceed 30 A/m.

- Do not use the device in the vicinity of strong magnetic fields (e.g., caused by transformers or magnetic iron).

Noise emission may occur when operating relay modules. Wireless reception may be disrupted in residential areas.

The device is a Class A product.

- Observe the requirements for noise emission for electrical and electronic equipment (EN 61000-6-4).
- Implement appropriate precautions against noise emission.

Faulty devices

The devices may be damaged following an error. Correct operation can no longer be ensured.

- In the event of an error, replace the device.

Only the manufacturer or their authorized representative may perform the following activities. Otherwise the warranty is invalidated.

- Repairs to the device
- Opening the housing

Taking out of service and disposal

- Dispose of the device in accordance with environmental regulations.
- Make sure that the device can never be reused.

6.1 Safety of machines or systems

Draw up and implement a safety concept

The machine or system manufacturer and the operator are responsible for the safety of the machine or system and the application in which the machine or system is used. In order to use the device described in this document, you must have drawn up an appropriate safety concept for your machine or system. This includes a risk assessment in accordance with the directives and standards specified in the EC Declaration of Conformity, as well as other standards.



The EC Declaration of Conformity can be downloaded for the product at phoenixcontact.net/products.

Risk assessment, validation and function test

- Before using the device, perform a risk assessment on the machine or system.
- Validate your entire safety system.
- Carry out a new validation every time you make a safety-related modification.
- Perform a function test on a regular basis.

Achievable safety integrity

Functional safety is guaranteed for the device as a single component. However, this does not guarantee functional safety for the entire machine or system. In order to achieve the desired safety level for the entire machine or system, define the safety requirements for the machine or system as well as how to implement them from both a technological and organizational perspective.

7 Function description

7.1 One or two-channel activation

The external enable signal of the failsafe controller or basic device is switched at A1.

The external enable signal can also be switched at A2 as an option.

7.2 Automatic start

The device starts automatically once it has received the external enable signal.

7.3 Safe shutdown

Once the external enable signal has been deactivated, the enabling current paths open and the contacts enter the safe state.

When the enabling current paths are open, the device is in the safe state.

The confirmation current path closes.

7.4 Diagnostics / proof test

The confirmation current path transmits safety-related status information.

Due to the forced guidance of the contacts, the confirmation current path closes when the enabling current paths open.

If required by the application, trace the confirmation current path back to the basic device.

The repeat testing required by standards can be carried out in two ways:

1. Continuity test for the confirmation current path
2. Evaluation of the failsafe controller via readback of the confirmation current path



See "Proof test".
See section "Feedback circuit connection versions".

If several devices are used, the N/C contacts of the confirmation current paths can be connected in series.

8 Function and time diagrams

8.1 Time diagram for automatic start

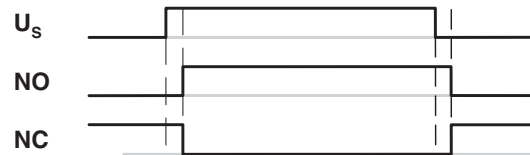

Figure 1 Time diagram for automatic start

Key:

U_s	Control/enable signal	A1/A2
NO	Undelayed enabling current paths	13/14 ... 53/54
NC	Confirmation current path, undelayed	71/72

9 Basic circuit diagram

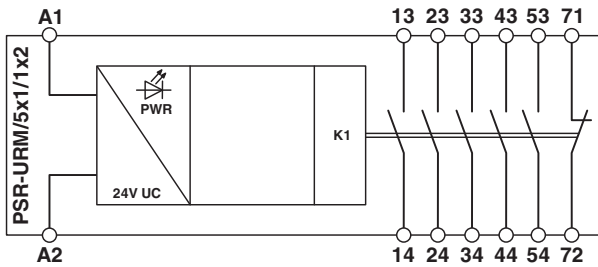

Figure 2 Block diagram

Key:

- A1** 24 V AC/DC control
- A2** 0 V control
- 13/14 ... 53/54** Undelayed enabling current paths
- 71/72** Confirmation current path, undelayed

9.1 Insulation coordination

	A1/ A2	13/14	23/24	33/34	43/44	53/54	71/72
A1/ A2	-	6 kV ST	6 kV ST	6 kV ST	6 kV ST	4 kV BI	4 kV BI
13/14	-	-	4 kV BI	4 kV BI	4 kV BI	6 kV ST	6 kV ST
23/24	-	-	-	4 kV BI	4 kV BI	6 kV ST	6 kV ST
33/34	-	-	-	-	4 kV BI	6 kV ST	6 kV ST
43/44	-	-	-	-	-	6 kV ST	6 kV ST
53/54	-	-	-	-	-	-	4 kV BI
71/72	-	-	-	-	-	-	-

Key:

- BI** Basic insulation
- ST** Safe isolation



Basic insulation

(rated surge voltage of 4 kV)

A mixture of SELV and PELV is strictly prohibited. Only switch 230 V AC at one of the enable contacts if the adjacent contact carries the same potential.

Safe isolation/reinforced insulation

(rated surge voltage of 6 kV)

Reinforced insulation (e.g., thanks to greater air clearances and creepage distances between conductive paths) is designed for one overvoltage category higher than basic insulation. This means that SELV circuits of $U \leq 25$ V AC or $U \leq 60$ V DC and circuits with higher voltages can be mixed.

10 Load curve

10.1 Ohmic load

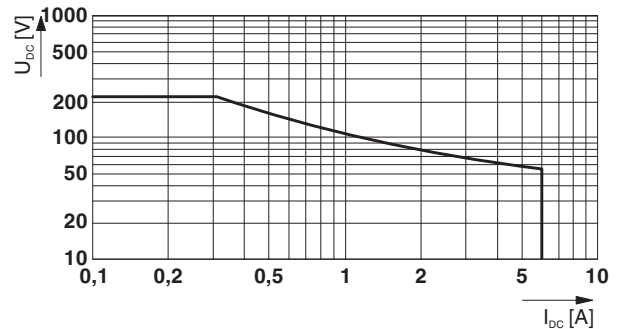

Figure 3 Relay load curve - ohmic load

11 Operating and indication elements

11.1 Connection versions

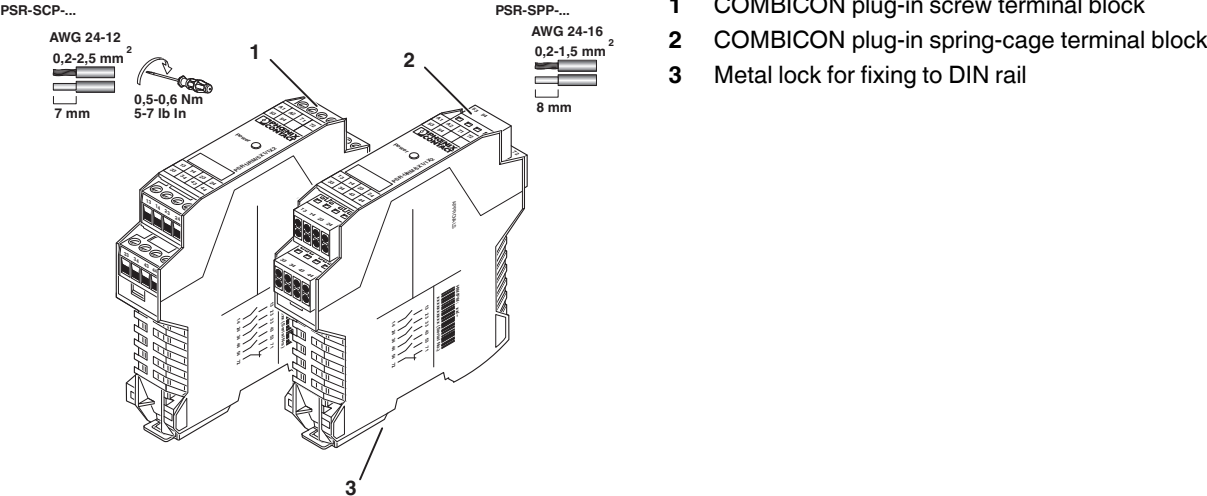
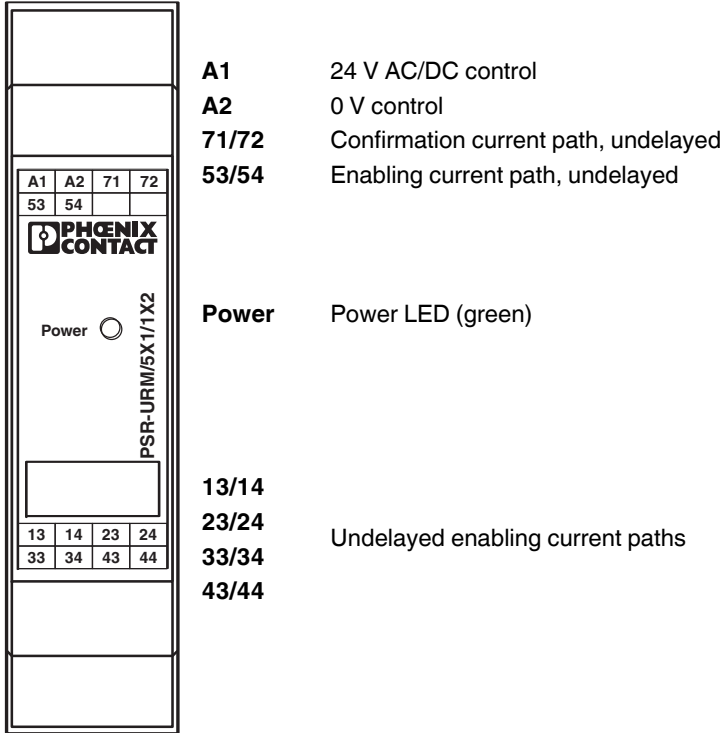

Figure 4 Connection versions

11.2 Connection assignment



- A1** 24 V AC/DC control
- A2** 0 V control
- 71/72** Confirmation current path, undelayed
- 53/54** Enabling current path, undelayed
- Power** Power LED (green)
- 13/14**
- 23/24** Undelayed enabling current paths
- 33/34**
- 43/44**

12 Mounting and removing

- Mount the device on a 35 mm DIN rail according to EN 60715.
- To remove the device, use a screwdriver to release the snap-on foot.

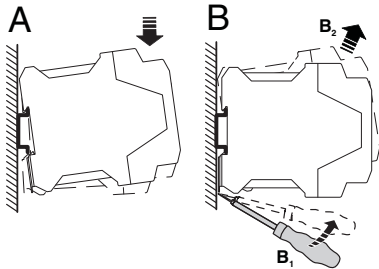

Figure 5 Mounting and removing

13 Wiring

- Connect the cables to the connection terminal blocks using a screwdriver.

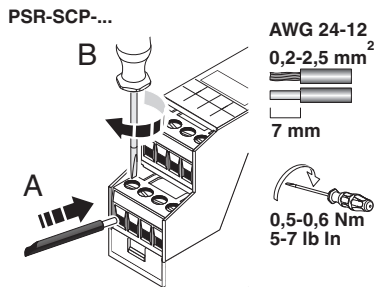

Figure 6 Connecting the cables for PSR-SCP-... (Screw terminal block)

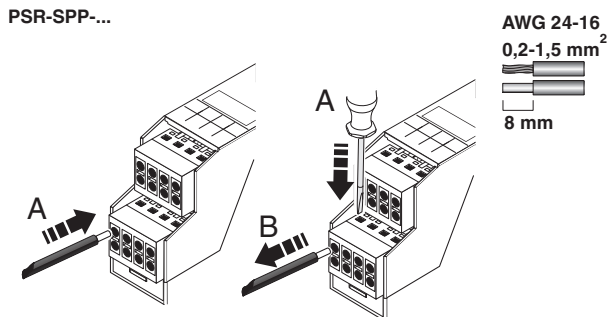

Figure 7 Connecting the cables for PSR-SPP-... (Spring-cage terminal block)



It is recommended that ferrules are used to connect stranded cables.



For compliance with UL approval, use copper wire that is approved for > 75°C.

13.1 Signal generator connection versions

- Connect suitable signal generators to A1/A2.

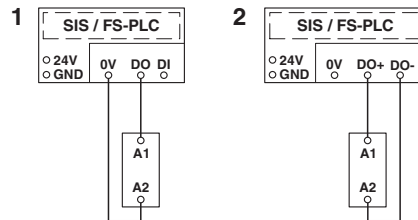

Figure 8 Signal generator connection versions

- 1 Single-channel control via failsafe controller
- 2 Two-channel control via failsafe controller

13.2 Feedback circuit connection versions

To carry out the optional diagnostic function via the confirmation current path, proceed as follows:

- Read the confirmation current path back to one of the digital inputs of the failsafe controller.
- Place the relevant N/C contacts in the confirmation current path to the digital input of the failsafe controller to monitor external contactors or extension devices with force-guided contacts.

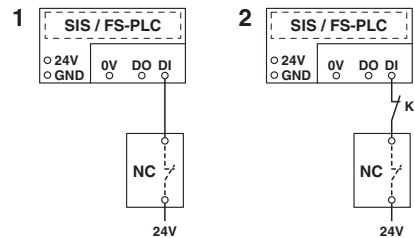

Figure 9 Feedback circuit connection versions

- 1 Confirmation current path without monitored contact extension
- 2 Confirmation current path with monitored contact extension

NC Confirmation current path 71/72

14 Startup

- Provide the external enable signal (24 V AC/DC) of the failsafe controller or the basic device at terminal block A1.

PWR LED lights up.

Enabling current paths 13/14 ... 53/54 close.

Confirmation current path 71/72 opens.

15 Calculating the power dissipation



The total power dissipation of the safety relay is based on the input power dissipation and the contact power dissipation for the same and for different load currents.

Input power dissipation

$$P_{\text{Input}} = U_B^2 / (U_S / I_S)$$

Contact power dissipation

With the same load currents:

$$P_{\text{Contact}} = n \cdot I_L^2 \cdot 100 \text{ m}\Omega$$

With different load currents:

$$P_{\text{Contact}} = (I_{L1}^2 + I_{L2}^2 + \dots + I_{Ln}^2) \cdot 100 \text{ m}\Omega$$

Total power dissipation

$$P_{\text{Total}} = P_{\text{Input}} + P_{\text{Contact}}$$

therefore

$$P_{\text{Total}} = U_B^2 / (U_S / I_S) + n \cdot I_L^2 \cdot 100 \text{ m}\Omega$$

or

$$P_{\text{Total}} = U_B^2 / (U_S / I_S) + (I_{L1}^2 + I_{L2}^2 + \dots + I_{Ln}^2) \cdot 100 \text{ m}\Omega$$

Key:

- P** Power dissipation in mW
- U_B** Applied operating voltage
- U_S** Rated control circuit supply voltage
- I_S** Rated control supply current
- n** Number of enabling current paths used
- I_L** Contact load current

16 Proof test

To verify the device function, proceed according to one of the following diagnostic options.



WARNING: Loss of functional safety due to malfunction.

If the proof test contains errors, the device no longer functions correctly.

- Replace the device.

16.1 Continuity test on confirmation current path

1. Deactivate A1.
2. Perform a continuity test for the confirmation current path.

Expectation: Continuity can be measured.

16.2 Evaluation of the failsafe controller via readback of the confirmation current path

1. Deactivate A1.
2. Read the confirmation current path back into one of the digital inputs of the failsafe controller.

Expectation: The failsafe controller receives a 24 V signal via the confirmation current path.

17 Application examples

17.1 High-demand application with failsafe controller

- Single-channel control
- Integration of the confirmation current path in the safe controller
- It is assumed that errors in the cable installation have been eliminated
- Suitable up to category 1, PL c (EN ISO 13849-1), SILCL 1 (EN 62061), SIL 1 (IEC 61508)



WARNING: Loss of functional safety!

The switch-on pulses sent by the controller (light test) can lead to brief, unwanted activation of the safety relay.

- Deactivate the light pulses/light tests.



WARNING: Loss of functional safety due to infiltration of process safety time!

If the evaluation of the confirmation current path is not performed in high-demand applications within the process safety time, this may lead to a loss of functional safety.

- Ensure that the evaluation of the confirmation current path is performed in high-demand applications within the process safety time.



Cross-circuits in the cable installation can be ruled out in the same electrical installation space or through mechanically protected cable installation.

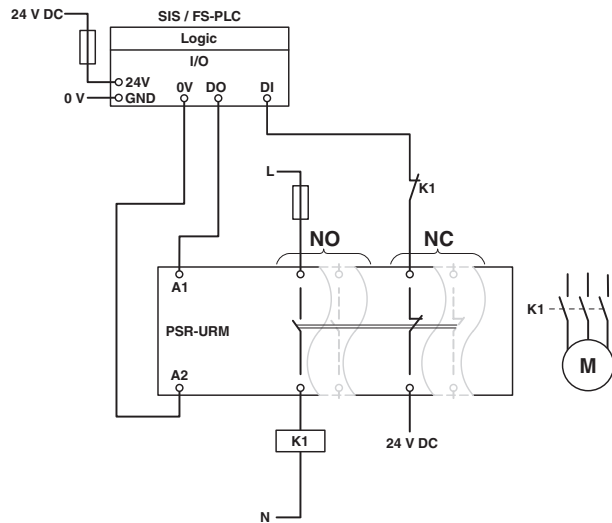

Figure 10 High-demand application with failsafe controller

Key:

SIS / FS-PLC	Safety Instrumented System / failsafe controller	
DI	Digital input	
DO	Digital output	
NO	Enabling current paths	13/14 ... 53/54
NC	Confirmation current path	71/72
K1	Force-guided contactor	

17.2 Low-demand application with failsafe controller

- Single-channel control
- It is assumed that errors in the cable installation have been eliminated
- Suitable up to category 1, PL c (EN ISO 13849-1), SILCL 1 (EN 62061), SIL 1 (IEC 61508)



WARNING: Loss of functional safety!
 The switch-on pulses sent by the controller (light test) can lead to brief, unwanted activation of the safety relay.

- Deactivate the light pulses/light tests.



Cross-circuits in the cable installation can be ruled out in the same electrical installation space or through mechanically protected cable installation.



The configuration path is not absolutely necessary for low-demand applications. However, readback is recommended so a potential error in the switching operation can be read into the controller. In any case, verify proper function with regular proof tests.

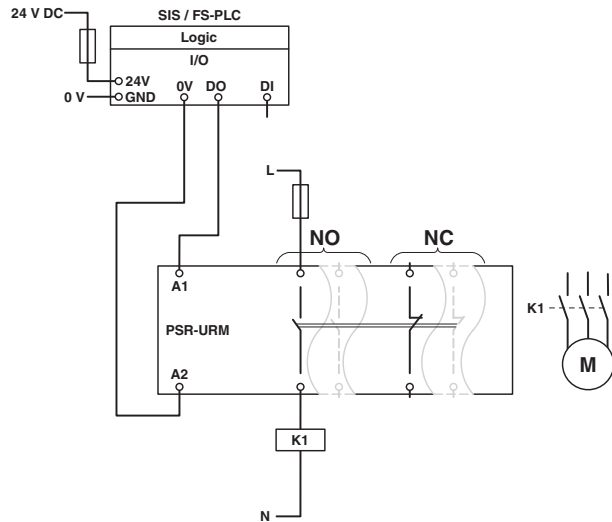

Figure 11 Low-demand application with failsafe controller

Key:

SIS / FS-PLC	Safety Instrumented System / failsafe controller	
DI	Digital input	
DO	Digital output	
NO	Enabling current paths	13/14 ... 53/54
NC	Confirmation current path	71/72
K1	Force-guided contactor	

18 Attachment

18.1 Using PSR devices at altitudes greater than 2000 m above sea level



The following section describes the special conditions for using PSR devices at altitudes greater than 2000 m above sea level. Observe the relevant device-specific data (technical data, derating, etc.) according to the product documentation for the individual device.

Altitude above sea level	Temperature derating factor
2000 m	1
2500 m	0.953
3000 m	0.906
3500 m	0.859
4000 m	0.813
4500 m	0.766

Using the device at altitudes **greater than 2000 m above sea level up to max. 4500 m above sea level** is possible under the following conditions:

1. Limit the rated control circuit supply voltage (U_S) in accordance with the table below. Observe the technical data for the device.

U_S according to the technical data for the device	U_S when used at altitudes greater than 2000 m above sea level
< 150 V AC/DC	U_S according to the technical data for the device still valid
> 150 V AC/DC	Limited to max. 150 V AC/DC

2. Limit the maximum switching voltage in accordance with the table below. Observe the technical data for the device.

Max. switching voltage according to the technical data for the device	Max. switching voltage when used at altitudes greater than 2000 m above sea level
< 150 V AC/DC	Max. switching voltage according to the technical data for the device still valid
> 150 V AC/DC	Limited to max. 150 V AC/DC

3. Reduce the maximum ambient temperature for operation by the corresponding factor in accordance with the table below.
4. If derating is specified, offset all the points of the derating curve by the corresponding factor in accordance with the table below.

Example calculation for 3000 m



The following calculation and the illustrated derating curve are provided as examples. Perform the actual calculation and offset the derating curve for the device used according to the technical data and the "Derating" section.

$$27\text{ °C} \cdot 0.906 \approx 24\text{ °C}$$

$$55\text{ °C} \cdot 0.906 \approx 49\text{ °C}$$

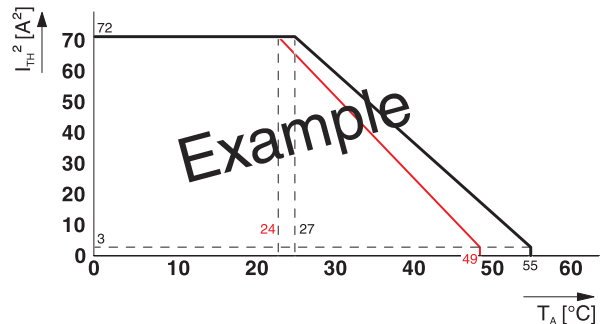

Figure 12 Example of a suspended derating curve (red)

18.2 Revision history

Version	Date	Contents
00	2017-06-15	First publication
01	2018-03-21	Chap. 4 Technical data: Safety parameters for IEC 61508 High demand and low demand changed, Chap. 5 added, Safety note on direct/indirect contact added to Chap. 6, Chap. 6.1 added