



Chipsmall Limited consists of a professional team with an average of over 10 year of expertise in the distribution of electronic components. Based in Hongkong, we have already established firm and mutual-benefit business relationships with customers from,Europe,America and south Asia,supplying obsolete and hard-to-find components to meet their specific needs.

With the principle of “Quality Parts,Customers Priority,Honest Operation,and Considerate Service”,our business mainly focus on the distribution of electronic components. Line cards we deal with include Microchip,ALPS,ROHM,Xilinx,Pulse,ON,Everlight and Freescale. Main products comprise IC,Modules,Potentiometer,IC Socket,Relay,Connector.Our parts cover such applications as commercial,industrial, and automotives areas.

We are looking forward to setting up business relationship with you and hope to provide you with the best service and solution. Let us make a better world for our industry!



## Contact us

Tel: +86-755-8981 8866 Fax: +86-755-8427 6832

Email & Skype: info@chipsmall.com Web: www.chipsmall.com

Address: A1208, Overseas Decoration Building, #122 Zhenhua RD., Futian, Shenzhen, China





## **PSR-TRISAFE system: Configurable safety modules and safe extension modules**

User manual

## User manual

# PSR-TRISAFE system: Configurable safety modules and safe extension modules

UM EN PSR-TRISAFE system, revision 02

2017-12-08

---

This user manual is valid for:

	Designation	Revision as of HW/FW	Order No.
<b>PSR-TRISAFE-S</b>	PSR-SCP-24DC/TS/S	10/1636	2986229
	PSR-SPP-24DC/TS/S	10/1636	2986232
<b>PSR-TRISAFE-M</b>	PSR-SCP-24DC/TS/M	10/2033	2986012
	PSR-SPP-24DC/TS/M	10/2033	2986025
<b>PSR-TS-SDI8-SDIO4</b>	PSR-SCP-24DC/TS/SDI8/SDIO4	10/1021	2986038
	PSR-SPP-24DC/TS/SDI8/SDIO4	10/1021	2986041
<b>PSR-TS-SDOR4</b>	PSR-SCP-24DC/TS/SDOR4/4x1	02/1002	2986096
	PSR-SPP-24DC/TS/SDOR4/4x1	02/1002	2986106

This user manual uses the following designations:

**Safety modules:**

Designation for the PSR-TRISAFE-S and PSR-TRISAFE-M modules

**Safe extension modules:**

Designation for the PSR-TS-SDI8-SDIO4 and PSR-TS-SDOR4 modules

# Table of contents

1	For your safety .....	7
1.1	Marking of warning notes.....	7
1.2	Qualification of users .....	7
1.3	Field of application of the product.....	8
1.3.1	Intended use .....	8
1.3.2	Product changes .....	9
1.4	Safety notes.....	9
1.4.1	General safety notes .....	9
1.4.2	Electrical safety .....	11
1.4.3	Safety of machines or systems .....	12
1.4.4	Safety when starting applications .....	13
1.5	Directives and standards .....	13
1.6	Documentation .....	14
1.7	Safety hotline.....	14
2	System description .....	15
2.1	PSR-TRISAFE safety system: Structure and method of operation .....	15
2.2	Using the system .....	18
2.3	Safe state .....	19
2.4	System startup and restart behavior .....	19
2.5	Error detection .....	21
2.6	Error state .....	21
2.7	Diagnostic tools .....	22
2.8	Password protection .....	22
3	PSR-TRISAFE-S and PSR-TRISAFE-M safety modules .....	23
3.1	Product description.....	23
3.1.1	Connecting extension devices .....	25
3.2	Operating modes (status) of the safety modules .....	26
3.3	Operating and indication elements .....	27
3.3.1	Diagnostics and status indicators .....	27
3.3.2	Confirm button .....	28
3.3.3	USB interface .....	28
3.3.4	IFS-CONFSTICK .....	30
3.4	Signal connections .....	31
3.4.1	Safe inputs .....	31
3.4.2	Safe outputs .....	32
3.4.3	Signal outputs .....	33
3.4.4	Clock outputs .....	33
3.4.5	Ground switching outputs .....	34
3.4.6	Supply connections .....	34

4	PSR-TS-SDI8-SDIO4 safe extension module .....	37
4.1	Product description.....	37
4.3	Signal connections .....	39
4.3.1	Safe inputs .....	39
4.3.2	Safe outputs .....	40
4.3.3	Clock/signal outputs .....	40
4.3.4	Supply connections .....	42
5	PSR-TS-SDOR4 safe extension module .....	43
5.1	Product description.....	43
5.3	Signal connections .....	46
5.3.1	Safe relay outputs .....	46
5.3.2	Signal outputs .....	48
5.3.3	Supply connections .....	48
6	Wiring examples .....	51
6.1	Notes on the wiring examples.....	51
6.2	Single-channel assignment of safe digital inputs .....	51
6.2.1	Cross-circuit monitoring enabled .....	51
6.2.2	Cross-circuit monitoring disabled, external supply .....	52
6.2.3	External supply (OSSD) .....	53
6.3	Two-channel equivalent assignment of safe digital inputs .....	54
6.3.1	Cross-circuit monitoring enabled, supply through T0 and T1 .....	54
6.3.2	Cross-circuit monitoring disabled, external supply .....	55
6.3.3	External supply (OSSD) .....	56
6.4	Two-channel non-equivalent assignment of safe digital inputs .....	57
6.4.1	Cross-circuit monitoring enabled, supply through T0 and T1 .....	57
6.4.2	Cross-circuit monitoring disabled, external supply .....	58
6.5	Safe digital outputs .....	59
6.5.1	Notes on the protective circuit for external relays/contactors (freewheeling circuit) .....	59
6.5.2	Single-channel assignment of safe digital outputs .....	60
6.5.3	Two-channel assignment of safe digital outputs .....	61
6.6	Safe relay outputs.....	62
6.6.1	Notes on the protective circuit for external relays/contactors (freewheeling circuit) .....	62
6.6.2	Single-channel assignment of safe relay outputs .....	62
6.6.3	Two-channel assignment of safe relay outputs .....	63

7	Assembly, removal, and electrical installation .....	65
7.1	Safety notes on assembly, removal and electrical installation .....	65
7.2	Assembly .....	66
7.2.1	Assembly instructions .....	66
7.2.2	Mounting location .....	66
7.2.3	Mounting work .....	67
7.3	Dismantling.....	68
7.4	Electrical installation .....	69
7.4.1	Connecting signal lines .....	70
7.4.2	Connecting the supply voltage .....	72
7.4.3	Typical connection of a PSR-TRISAFE system .....	75
8	Firmware update .....	77
8.1	Safety notes for the firmware update .....	77
8.2	Requirements for firmware update.....	78
8.3	Updating the firmware.....	78
9	SAFECNF configuration software .....	79
9.1	Installing the software .....	79
9.2	Accessing the software help .....	80
10	Configuration and startup .....	81
10.1	Example for configuration and startup .....	81
10.2	Downloading configuration from the SAFECNF configuration software .....	84
10.3	Downloading the configuration using the IFS-CONFSTICK memory module .....	88
10.4	Uploading the configuration from the safety module .....	90
10.5	Function test.....	91
10.5.1	Performing function test using online mode .....	91
11	Diagnostics .....	93
11.1	Diagnostics using LED indicators on the module.....	93
11.1.1	PSR-TRISAFE-S and PSR-TRISAFE-M .....	94
11.1.2	PSR-TS-SDI8-SDIO4 .....	97
11.1.3	PSR-TS-SDOR4 .....	98

12	Problems and solutions .....	99
12.1	General.....	99
12.2	Graphical connection editor.....	99
12.3	Parameterization editor.....	100
12.4	Online communication between SAFECONF and the safety module .....	101
12.5	Communication between the safety module and the safe extension module.....	103
12.6	Safety module messages .....	103
13	Maintenance, repair, decommissioning, and disposal .....	105
13.1	Maintenance.....	105
13.2	Repair.....	105
13.3	Decommissioning and disposal.....	105
14	Technical data and ordering data .....	107
14.1	Technical data of the PSR-TRISAFE-S and PSR-TRISAFE-M .....	107
14.2	Technical data of PSR-TS-SDI8-SDIO4 .....	113
14.3	Technical data of PSR-TS-SDOR4 .....	118
14.4	Approvals .....	124
14.5	Conformance with EMC Directive.....	124
14.6	System requirements of the configuration software SAFECONF.....	125
14.7	Ordering data.....	126
14.7.1	PSR-TRISAFE modules .....	126
14.7.2	Software .....	126
14.7.3	Accessories .....	127
14.7.4	Gateways .....	128
14.8	Documentation .....	129
A	Technical appendix.....	131
A 1	Calculating the power dissipation .....	131
A 2	Shutdown time of the PSR-TRISAFE system .....	135
A 3	Using PSR-TRISAFE modules at altitudes greater than 2000 m above sea level.....	136
B	Appendix for document lists.....	139
B 1	List of figures .....	139
B 2	List of tables .....	143
B 3	Index.....	145
C	Revision history .....	149

# 1 For your safety

Read this user manual carefully and keep it for future reference.

## 1.1 Marking of warning notes



This symbol indicates hazards that could lead to personal injury. There are three signal words indicating the severity of a potential injury.

### **DANGER**

Indicates a hazard with a high risk level. If this hazardous situation is not avoided, it will result in death or serious injury.

### **WARNING**

Indicates a hazard with a medium risk level. If this hazardous situation is not avoided, it could result in death or serious injury.

### **CAUTION**

Indicates a hazard with a low risk level. If this hazardous situation is not avoided, it could result in minor or moderate injury.



This symbol together with the **NOTE** signal word warns the reader of actions that might cause property damage or a malfunction.



Here you will find additional information or detailed sources of information.

## 1.2 Qualification of users

The use of products described in this user manual is oriented exclusively to:

- Electrically skilled persons or persons instructed by them. The users must be familiar with the relevant safety concepts of automation technology as well as applicable standards and other regulations.
- Qualified application programmers and software engineers. The users must be familiar with the relevant safety concepts of automation technology as well as applicable standards and other regulations.



## 1.3 Field of application of the product

Only use the PSR-TRISAFE system in accordance with the area of application described in this section.

### 1.3.1 Intended use

Use the safety modules and safe extension modules of the PSR-TRISAFE system only in accordance with the information provided in this section.

#### PSR-TRISAFE system

The intended use for the PSR-TRISAFE system is safe switch-off. Safe switch-on does **not** fall under the intended use.

All modules of the PSR-TRISAFE system are intended for use in industrial applications.

The safety modules and safe extension modules can only perform their safety-related tasks if they have been integrated into the execution process correctly and in such a way as to avoid errors.

You must observe all information in this user manual as well as the user manuals and help listed in "Documentation" on page 14.

Only use the modules of the PSR-TRISAFE system in acc. with the provided technical data. See Section 14 „Technical data and ordering data“ from page 107.

For more information on using the PSR-TRISAFE system, refer to "Using the system" on page 18.

#### PSR-TRISAFE-S and PSR-TRISAFE-M

The PSR-TRISAFE-S and PSR-TRISAFE-M modules are configurable safety modules with 20 safe inputs and four safe outputs. The inputs are for analyzing signal generators that are relevant to safety, e.g. emergency stop buttons or safety doors. Safety-related circuits are interrupted via the outputs. Additionally, four signal outputs, two clock outputs and two ground switching outputs are available.

The PSR-TRISAFE-S safety module is a standalone device and cannot be combined with safe extension modules.

The PSR-TRISAFE-M safety module can be supplemented with safe inputs and outputs by means of safe extension modules of the PSR-TRISAFE system.

At both safety modules, you can connect a gateway for transmitting diagnostic data.

#### PSR-TS-SDI8-SDIO4

The PSR-TS-SDI8-SDIO4 safe extension module is an extension to the PSR-TRISAFE-M safety module. With it, the following additional inputs and outputs are available: four configurable inputs or outputs, two configurable clock or signal outputs, as well as eight safe inputs.

#### PSR-TS-SDOR4

The PSR-TS-SDOR4 safe extension module is an extension to the PSR-TRISAFE-M safety module. With it, four additional safe relay outputs and four signal outputs are available.

#### SAFECONF

The SAFECONF safe configuration software is intended for configuring the safety modules and the connected extension modules.

#### Safe functional blocks and functions in SAFECONF

The SAFECONF configuration software provides you with safe functional blocks and functions for creating the safety logic. These are designed solely for use within the safety module and support specific safety functions.

The safe functional blocks and functions can only perform their safety-related tasks within the safe control system if they have been integrated into the execution process correctly and in such a way as to avoid errors.

### 1.3.2 Product changes

Modifications to hardware and firmware of the device are not permitted.

Incorrect operation or modifications to the device can endanger your safety or damage the device. Do not repair the device yourself. If the device is defective, please contact Phoenix Contact.

## 1.4 Safety notes

### 1.4.1 General safety notes



**WARNING: Severe danger due to improper use**

Depending on the application, inappropriate use of the PSR-TRISAFE system may pose serious risks for the user.

- Observe the safety notes in this Section.
- Observe the warning instructions provided elsewhere in this document.

#### Documentation



Observe all information in this user manual and the accompanying documents. See Section "Documentation" on page 14.

#### Safety of personnel and equipment

The safety of personnel and equipment can only be assured if the modules and the safe blocks are used correctly:  
See Section "Intended use" on page 8.

#### Qualified personnel

In terms of this user manual, qualified personnel are persons who, because of their education, experience and instruction, and their knowledge of relevant standards, regulations, accident prevention, and service conditions, have been authorized to carry out any required operations, and who are able to recognize and avoid any possible dangers.

In the context of the use of the PSR-TRISAFE system with SAFECONF configuration software and safe functional blocks, the following operations may only be carried out by qualified personnel:

- Planning, parameterization, configuration (development of the safety logic)
- Installation, startup, servicing
- Maintenance, decommissioning

#### Requirements

Knowledge of the following topics and products is required:

- The safety modules and safe extension modules of the PSR-TRISAFE system that are used
- The periphery used (extension devices, sensors, actuators)
- Operation of the SAFECONF configuration software
- Safety technology systems
- Safety regulations in the field of application

## PSR-TRISAFE system

---

### **Error detection**

Depending on the wiring and the parameterization, the safety modules and safe extension module of the PSR-TRISAFE system detects errors within the safety equipment.

### **Do not open the housing**

It is prohibited to open the module housing. If the housing is opened, the function of the PSR-TRISAFE modules can no longer be ensured.

### **Mismatching and polarity reversal of connections**

Take measures to prevent the incorrect connection, polarity reversal, and manipulation of connections.

The individual terminal block bases of all PSR-TRISAFE modules are mechanically coded to prevent confusion or connecting them the wrong way round.

## 1.4.2 Electrical safety



### **WARNING: Loss of safety function/hazardous shock currents**

Incorrect installation can result in the loss of the safety function as well as hazardous shock currents. Depending on the application, there may be serious risks for the user.

- Observe the notes on electrical safety.
- Observe the warning instructions provided elsewhere in this document.
- Plan the devices used and their installation in the system in accordance with the specific requirements.
- Recheck plants and systems that have been retrofitted with the safety relay module.
- Pay attention to the information in the user documentation of other devices used (e.g. sensors, actuators or extension devices).

### **Direct/Indirect contact**

Protection against direct and indirect contact in accordance with VDE 100 Part 410 must be ensured for all components connected to the system. In the event of an error, parasitic voltages must not occur (single-fault tolerance).

Measures required:

- Using power supply units with safe isolation (PELV)
- Decoupling circuits, which are not PELV systems  
With following components: optocouplers, relays, and other components which meet the requirements of safe isolation

### **Safe isolation**

Only use devices with safe isolation if dangerous contact voltages can occur at their connections.

### **Power supply units for 24 V supply**

Only use power supply units with safe isolation and PELV in accordance with EN 50178/VDE 0160. This prevents short circuits between primary and secondary sides.

Connect the GND connection on the output side of the power supply unit to the functional earth ground (FE) of the system.

### **Ground contact**

Make sure that all inputs and outputs of the system are connected to the same ground.

### **Insulation rating**

When selecting the equipment, please take into consideration the dirt and surge voltages which may occur during operation. If necessary, implement additional measures for voltage limitation.

### **Installation space and mounting position**

Observe the requirements for installation space and mounting position as specified in the technical data.

### **ESD**



### **NOTE: Electrostatic discharge**

Electrostatic discharge can damage or destroy components. When handling the device, observe the necessary safety precautions against electrostatic discharge (ESD) according to EN 61340-5-1 and IEC 61340-5-1.

### 1.4.3 Safety of machines or systems

The machine/system manufacturer and the operator are responsible for the safety of the machine or system and the application in which the machine or system is used.

#### Draw up and implement a safety concept

In order to use the system described in this document with the associated safe functional blocks, you must have drawn up an appropriate safety concept for your machine or system. This includes a hazard and risk analysis in acc. with the directives and standards specified in Section "Directives and standards" on page 13.

The target safety integrity is ascertained on the basis of the risk analysis.

- SIL in acc. with IEC 61508
- SILCL in acc. with EN 62061
- Cat./PL in acc. with EN ISO 13849-1

The following depends on the identified safety integrity level:

- The wiring of safe sensors, control devices and actuators within the overall safety function
- The use of safe blocks in the safety logic  
You can create the safety logic with the aid of the SAFECONF configuration software.

#### Safety-related equipment

In order to use the PSR-TRISAFE system properly, safety-related equipment must be provided on the machine.

This includes, for example:

- Emergency stop button
- Protective cover switch
- Enable switch
- Light grid

#### Checking hardware and parameterization

Carry out a validation every time you make a safety-related modification to your overall system.

Use the relevant checklists when carrying out the validation. Also enter the details requested in the "Project Information" dialog box in the SAFECONF safe configuration software.

Use your test report to ensure that:

- Are the safe sensors and actuators connected correctly in the PSR-TRISAFE safety application? To do this, also use the "Wiring check" function in the SAFECONF configuration software.
- Is the parameterization of the inputs and outputs of the safety modules and the safe extension modules correct?
- Have the signals been connected to the safe sensors and actuators correctly (single-channel or two-channel)?
- Is the cross-circuit detection implemented in your application, if required (see page 22)?
- Are all safe functional blocks and functions in the SAFECONF configuration software connected correctly?

#### Connecting USB connection

For safe operation of the machine or system, no USB connection to the safety modules may exist.

For further information, please refer to Section "USB interface" on page 28.

#### 1.4.4 Safety when starting applications

Take the following into consideration when determining the start conditions for your machine or system:

- The machine or system may only be started if it has been ensured that no one is present in the danger zone.
- Meet the requirements of EN ISO 13849-1 with regard to the manual reset function.

This applies to:

- Switching on safe devices
- Acknowledging device error messages
- Removing startup inhibits for safety functions

#### Observing startup behavior

Some of the safe functional blocks in the SAFECONF configuration software have parameters for specifying a startup inhibit and/or a restart inhibit.

For further information, please refer to Section “System startup and restart behavior” on page 19.

### 1.5 Directives and standards

The standards that are complied with by the PSR-TRISAFE system can be found in the certificate of the registration office and the EC declaration of conformity.

These documents are available on the Internet.

See [phoenixcontact.net/products](http://phoenixcontact.net/products).

## 1.6 Documentation

### Latest documentation

Always use the latest documentation. Changes or additions to documentation can be found on the Internet.

See [phoenixcontact.net/products](http://phoenixcontact.net/products).

You must observe all information from the following sources:

- Technical description of the safety modules
- Technical description of the safe extension modules
- User documentation for I/O devices (e.g., sensors/actuators, etc.) connected to the PSR-TRISAFE modules and connected to safe functional blocks in the safety logic (SAFECONF configuration software)
- Documentation for supplementary standard technology
- Help for SAFECONF safe configuration software and for each of the safe blocks (see “Accessing the software help” on page 80)



For additional information and detailed step-by-step instructions for the SAFECONF configuration software, please refer to the online help of the software.

## 1.7 Safety hotline

Should you have any technical questions, please contact our 24-hour hotline.

Phone: +49 5281 9462777

E-mail: [safety-service@phoenixcontact.com](mailto:safety-service@phoenixcontact.com)

## 2 System description

### 2.1 PSR-TRISAFE safety system: Structure and method of operation

#### Overall system: Hardware and software

The PSR-TRISAFE safety system consists of the following components.

#### When using the PSR-TRISAFE-S safety module:

- PSR-TRISAFE-S safety module
- SAFECONF configuration software
- Safe control devices, sensors and actuators (depending on the application)

#### When using the PSR-TRISAFE-M safety module:

- PSR-TRISAFE-M safety module
- Optional, safe PSR-TS-SDI8-SDIO4 / PSR-TS-SDOR4 extension module
- SAFECONF configuration software
- Safe control devices, sensors and actuators (depending on the application)

The diagram below illustrates the overall system in an example of use with the PSR-TRISAFE-M.

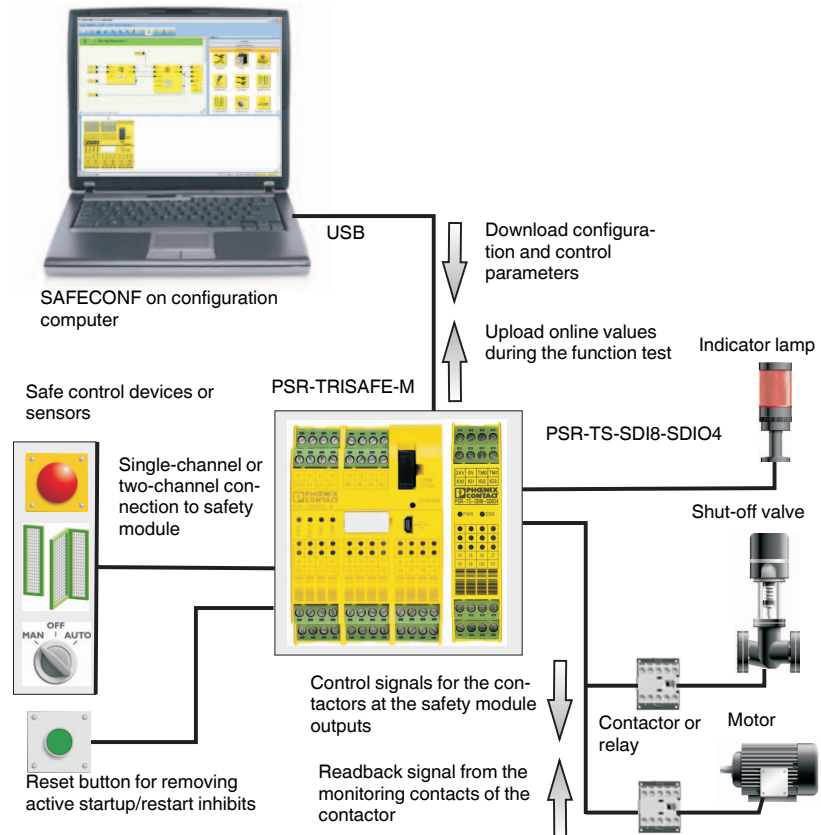

Figure 2-1 Example structure of a safety system with PSR-TRISAFE-M



### Communication via USB

The USB interface is used for communication between the PSR-TRISAFE-S or PSR-TRISAFE-M safety modules and the configuration software.

**WARNING: Standard operation**

The USB interface is not ESD protected. When there is a USB connection, the safety module is in standard operation mode. The safety function cannot be executed properly.

- Use the USB connection for startup only.
- Disconnect the USB connection for regulator operation.

The safety module and configuration software PC communicate in both directions:

**PC → Safety module**

The configuration data and device parameters are downloaded from the configuration PC to the safety module. Configuration data refers to the application logic which you created using the SAFECNF configuration software.

You can also download the configuration by means of the pluggable IFS-CONFSTICK memory module. Please refer to “Downloading configuration from the SAFECNF configuration software” on page 84 and “Downloading the configuration using the IFS-CONFSTICK memory module” on page 88.

**Safety module → PC**

For diagnostic purposes, online values can be read from the safety module via the USB interface and displayed “live” in the software. For more detailed information, please refer to “Function test” on page 91.

### Communication via DIN rail connector

The PSR-TRISAFE-S safety module is equipped with an interface for the yellow PSR-TBUS DIN rail connector. The PSR-TRISAFE-M safety module has two interfaces for the yellow PSR-TBUS.

In combination with the green TBUS DIN rail connector, connect max. one standard extension device (gateway) to the PSR-TRISAFE-S or PSR-TRISAFE-M safety module.

At the PSR-TRISAFE-M safety module, connect up to ten safe extension modules additionally by using more yellow PSR-TBUS DIN rail connectors.

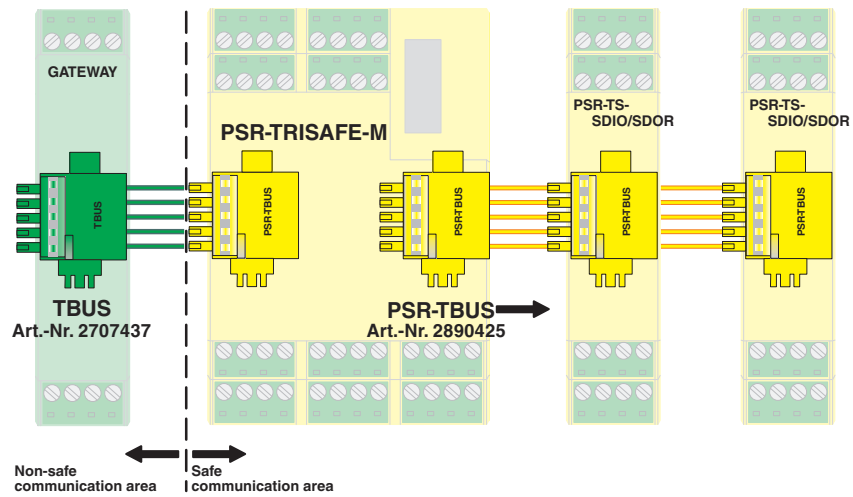

Figure 2-2 Safety module extension PSR-TRISAFE-M



Other standard bus devices are possible. For more information, refer to the user documentation of the gateway used, under [phoenixcontact.net/products](http://phoenixcontact.net/products).

Communication between the safety modules and the standard or safe extension modules is automatically performed via the connectors of the DIN rail connector. See also Section “Assembly” on page 66.



**NOTE: Wear on the connectors**

Up to eight mating cycles are permitted for connecting the modules by means of the DIN rail connector.



Observe the maximum continuous current for extension modules supplied via the PSR-TBUS, as well as the technical data of the PSR-TRISAFE system. See Section “Technical data and ordering data” on page 107.

## 2.2 Using the system

### Safety circuits

The safety modules of the TRISAFE system offer flexible configuration. For the creation of the safety logic, the system has safe functional blocks. With the TRISAFE system, you can implement various safety functions in different safety circuits. Some of the most important options are:

- Emergency stop monitoring
- Safety door monitoring (with and without locking)
- Two-hand controls (type II and III)
- External device monitoring (EDM)
- Monitoring and checking electro-sensitive protective equipment
- Mode selector switch (evaluation of a mode selector switch and an enable switch)
- Muting applications (light grid monitoring with parallel muting)



#### Examples of use:

In the help of the SAFECONF configuration software, you can find examples of use for the safe functional blocks, with typical applications for each block.

The safety logic configured in the configuration software, as well as the wiring of the safety modules and the safe extension modules, is displayed in the form schematic diagrams.

The online help also includes typical signal sequence diagrams which illustrate the behavior of each function block.

The following examples of use are included in the online help for the functional blocks:

- Single-channel and two-channel emergency stop circuits
- Single-channel and two-channel safety door monitoring, with and without interlocking
- Mode selector switch selection with interlocking of the set operating mode and manual operating mode acknowledgment
- Evaluation of a three-position enable switch with confirmation of the selected safe operating mode
- Parallel muting with two sensors
- Evaluation of a light curtain connected via a single channel
- Type II and Type III two-hand control devices

## 2.3 Safe state

The safe state of an output terminal point is power off mode (signal value: "0").

TRISAFE system can enter a safe state in the following cases:

1. Operating state (by triggering the safety function)
2. Error detection in I/O devices
3. Device error
4. Parameterization error
5. Error detection during safe communication

## 2.4 System startup and restart behavior



### **WARNING: Unintentional machine startup**

Startup/restart following power up and when there is no longer a demand of the safety function can result in unintentional machine startup.

- Please note the following:
  - After the configuration has been completed, the module immediately starts up.
  - The module immediately starts up again once the trigger for the safety function has been reset.
- If you do not want the machine to start up/restart automatically, configure the startup/restart behavior accordingly in the safety logic.

### **Startup**

"Startup" refers to the behavior of the PSR-TRISAFE-S or PSR-TRISAFE-M safety modules and the optional safe extension modules after switching on or applying supply voltage and following configuration via USB interface or IFS-CONFSTICK.

Unless a startup inhibit is configured, the safety module starts up immediately following successful configuration (i.e., after the "Confirm" button has been pressed). The safe inputs are evaluated and the outputs controlled accordingly.

### **Restart**

"Restart" refers to the behavior of the safety modules and the optional safe extension modules after the safety function is triggered and following a return to normal operation. The return to normal operation is for example achieved by unlocking the emergency stop control device once safe operation is possible again.

With an active startup/restart inhibit, the corresponding safe module output remains in the safe state. This prevents unintentional startup/restart of a machine controlled via the relevant output.

## Reset button



### **WARNING: Unintentional machine startup**

The acknowledgment of an error immediately returns the safe input or output to the operating state.

- Before acknowledging an error you must make sure that the acknowledgment will not cause the machine to switch to a hazardous state.
- When planning the machine or system, make sure that acknowledgment is only possible if the danger zone is visible.



With the manual reset function, a machine start may not be triggered in accordance with EN ISO 13849-1.

An active startup inhibit/restart inhibit can be removed by pressing a reset button that is connected and appropriately wired to the safety module or to the safe extension modules.

The reset signal is simultaneously used to exit the error state once the error cause has been removed.

## Implementation using safe functional blocks

To implement a startup inhibit/restart inhibit, you use the safe functional blocks in the SAFECNF configuration software which have the relevant parameters for activating the startup inhibit and/or restart inhibit.

To configure a startup inhibit for a specific safe output, for example, this output must be directly linked in the safety logic to the output of a safe function block, for which a startup inhibit is set via the parameters.



For more information on implementing a startup/restart inhibit, refer to the help of the SAFECNF configuration software.

## 2.5 Error detection

Depending on the wiring and the parameterization, the safety modules and safe extension modules of the PSR-TRISAFE system detects the following errors at the safe inputs and outputs:

- Short circuit of outputs
- Cross-circuit of inputs or outputs
- Overload at the outputs

## 2.6 Error state

Stop category 1 only in error-free state



**NOTE: Immediate shutdown could cause material damage.**

The device only ensures stop category 1 during **error-free operation**. In the event that the supply voltage is lost or an internal error occurs, the device behaves in acc. with stop category 0.

- Do **not** use the device for applications in which stop category 1 also has to be observed in the event of an error.

Operating time in the error state



**WARNING: Loss of the safe state in the failure state**

In the failure state, internal module tests are no longer run and it is possible that the safe state may be exited due to an accumulation of errors.

- In case the module enters an error state, then assess, acknowledge, or rectify the error within 72 hours.

## 2.7 Diagnostic tools

### SAFECONF diagnostics

Depending on the device, the TRISAFE system modules together with the SAFECONF configuration software provide various tools that can be used to diagnose the active configuration on the safety module:

- Hardware diagnostics in the event of a safe function block error
- Wiring check
- Tooltips in the connection editor
- Diagnostics and status indicators at the module
- Additional diagnostic options using gateways



For information on hardware diagnostics, wiring checks and tool tips, refer to the help of the SAFECONF configuration software.

### Diagnostics and status indicators

You can find an overview of the diagnostics and status indicators of the individual modules in the respective section.

- PSR-TRISAFE-S and PSR-TRISAFE-M: see “Diagnostics and status indicators” on page 27.
- PSR-TS-SDI8-SDIO4: See “Diagnostics and status indicators” on page 38.
- PSR-TS-SDOR4: See “Diagnostics and status indicators” on page 45.

### Diagnostics via gateways

You can connect your PSR-TRISAFE system to a higher-level controller via gateways. Diagnostics readouts are bus-specific.



For information on gateway diagnostics, refer to the following application note: AH EN PSR-TRISAFE System Diagnostics  
See [phoenixcontact.net/products](http://phoenixcontact.net/products).

You can find gateways that are suitable for use with the PSR-TRISAFE system in the accessories section “Gateways” on page 127.

## 2.8 Password protection

With two passwords, the TRISAFE system and SAFECONF provide double protection against unauthorized changes to the configuration and the project in the configuration software.



For additional information on password protection, refer to the help of the SAFECONF configuration software.

## 3 PSR-TRISAFE-S and PSR-TRISAFE-M safety modules

The PSR-TRISAFE-S and PSR-TRISAFE-M safety modules are largely identical in function and basic design.



The description of the two safety modules is summarized jointly in this section. Also observe the additional information provided for the PSR-TRISAFE-M and the safe extension module.

### Difference between PSR-TRISAFE-S and PSR-TRISAFE-M

The difference between the two safety modules lies in the following properties:

- SAFECONF diagnostics
- Connection option for safe extension modules of the PSR-TRISAFE system

### 3.1 Product description



Pay attention to the technical data of the safety module. See “Technical data of the PSR-TRISAFE-S and PSR-TRISAFE-M” on page 107.

#### Safe digital inputs

PSR-TRISAFE-S and PSR-TRISAFE-M are configurable safety modules with 20 safe digital inputs. The inputs are used to connect safe sensors or control devices. The maximum number of sensors/control devices depends on the wiring:

- Single-channel wiring: maximum 20 safe sensors/control devices
- Two-channel wiring: maximum 10 safe sensors/control devices

#### Safe digital outputs

The safety modules have four safe digital outputs. The outputs are controlled after the incoming signals have been evaluated depending on the configuration.

#### Ground switching outputs

The safety modules have two ground switching outputs. With the ground switching outputs, you can, for example, switch off a contactor connected to the safety module. The switch-off can be performed via both the 24-V output and ground. Use of the ground switching outputs increases the shutdown protection and cross-circuit protection of the safety circuit.

#### Digital signal outputs

The safety modules have four non-safety-related digital signal outputs. You can use the signal outputs to control a standard PLC or signaling units, for example.

#### Safe clock outputs

The safety modules have two clock outputs. Depending on the configuration, the asynchronous test clocks provide safe cross-circuit detection at the inputs of the safety modules.

#### Connection technology

The safety modules are available with either screw connections or spring-cage connections. All connection terminal blocks can be plugged in. The individual terminal block bases are mechanically coded to prevent confusion or connecting them the wrong way round.



Connection versions

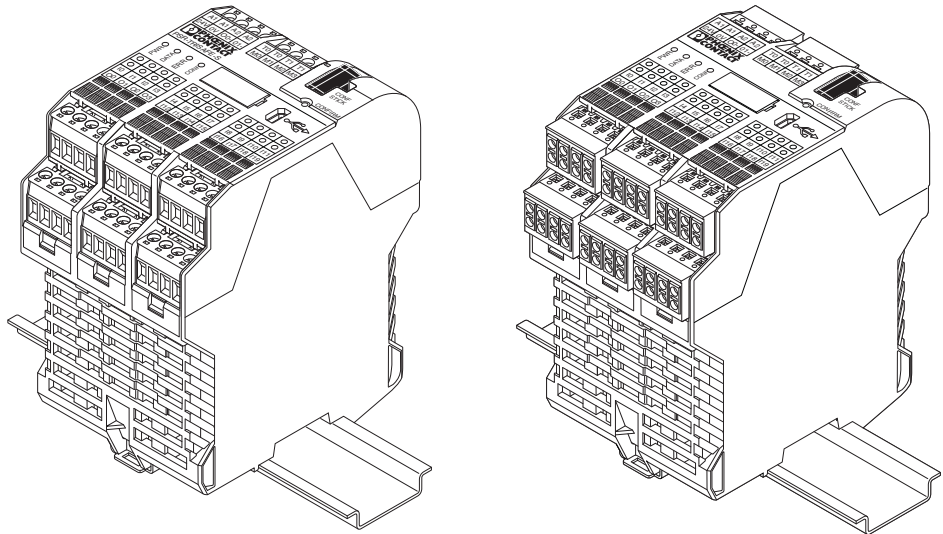

Figure 3-1 Screw terminal blocks (left) and spring-cage terminal blocks (right)

Block diagrams

PSR-TRISAFE-S:

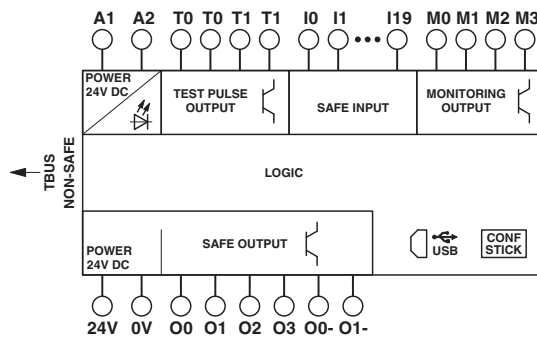

Figure 3-2 Block diagram PSR-TRISAFE-S

PSR-TRISAFE-M:

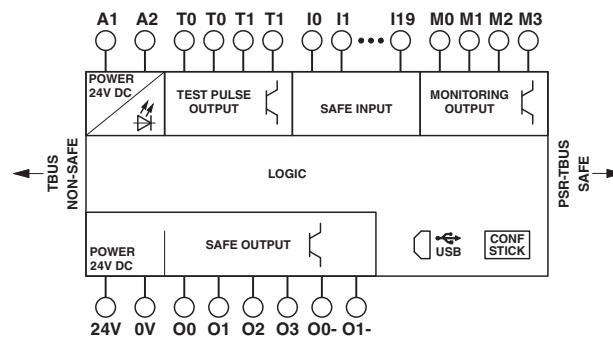

Figure 3-3 Block diagram PSR-TRISAFE-M

**Configuration**

You can create the configuration of the safety module with the SAFECONF configuration software. Subsequently, you load the configuration into the safety module via the USB interface.



**WARNING: Standard operation**

The USB interface is not ESD protected. When there is a USB connection, the safety module is in standard operation mode. The safety function cannot be executed properly.

- Use the USB connection for startup only.
- Disconnect the USB connection for regulator operation.

**Difference in SAFECONF**

In the SAFECONF configuration software, 16 external signals are available for the PSR-TRISAFE-S safety module.

For the PSR-TRISAFE-M safety module, 64 external signals are available. Additionally it is possible to use diagnostic addresses for diagnosing modules.



For additional information regarding the SAFECONF configuration software, refer to Section "SAFECONF configuration software" on page 79 or the Help system provided with the software.

**3.1.1 Connecting extension devices**



Also read "Communication via DIN rail connector" on page 16.

**Connecting standard extension modules (gateways):**

**Standard extension:  
PSR-TRISAFE-S/-M**

At both safety modules, you can connect max. one gateway for transmitting diagnostic data. Install the gateway on the left next to the safety module.



For information on gateway diagnostics, refer to the following application note:  
AH EN PSR-TRISAFE System Diagnostics  
See [phoenixcontact.net/products](http://phoenixcontact.net/products).

You can find gateways that are suitable for use with the PSR-TRISAFE system in the accessories section "Gateways" on page 127.

**Connecting safe extension modules:**

**Safe extension: only  
PSR-TRISAFE-M**

Only the PSR-TRISAFE-M safety module can be extended by means of the safe extension modules of the PSR-TRISAFE system. You can install up to ten safe extension modules on the right next to the PSR-TRISAFE-M safety module.



For more information on the safe extension modules, refer to section "PSR-TS-SDI8-SDIO4 safe extension module" on page 37 and "PSR-TS-SDOR4 safe extension module" on page 43.