



Chipsmall Limited consists of a professional team with an average of over 10 year of expertise in the distribution of electronic components. Based in Hongkong, we have already established firm and mutual-benefit business relationships with customers from,Europe,America and south Asia,supplying obsolete and hard-to-find components to meet their specific needs.

With the principle of “Quality Parts,Customers Priority,Honest Operation,and Considerate Service”,our business mainly focus on the distribution of electronic components. Line cards we deal with include Microchip,ALPS,ROHM,Xilinx,Pulse,ON,Everlight and Freescale. Main products comprise IC,Modules,Potentiometer,IC Socket,Relay,Connector.Our parts cover such applications as commercial,industrial, and automotives areas.

We are looking forward to setting up business relationship with you and hope to provide you with the best service and solution. Let us make a better world for our industry!



## Contact us

Tel: +86-755-8981 8866 Fax: +86-755-8427 6832

Email & Skype: info@chipsmall.com Web: www.chipsmall.com

Address: A1208, Overseas Decoration Building, #122 Zhenhua RD., Futian, Shenzhen, China



# EiceDRIVER™ Compact

High voltage gate driver IC

## 2EDL family

600 V half bridge gate drive IC

2EDL23I06PJ

2EDL23N06PJ

EiceDRIVER™ Compact

## Final datasheet

<Revision 2.2>, 01.06.2016

Final

**Edition 01.06.2016**

**Published by  
Infineon Technologies AG  
81726 Munich, Germany**

**© 2016 Infineon Technologies AG  
All Rights Reserved.**

### **Legal Disclaimer**

The information given in this document shall in no event be regarded as a guarantee of conditions or characteristics. With respect to any examples or hints given herein, any typical values stated herein and/or any information regarding the application of the device, Infineon Technologies hereby disclaims any and all warranties and liabilities of any kind, including without limitation, warranties of non-infringement of intellectual property rights of any third party.

### **Information**

For further information on technology, delivery terms and conditions and prices, please contact the nearest Infineon Technologies Office ([www.infineon.com](http://www.infineon.com)).

### **Warnings**

Due to technical requirements, components may contain dangerous substances. For information on the types in question, please contact the nearest Infineon Technologies Office.

Infineon Technologies components may be used in life-support devices or systems only with the express written approval of Infineon Technologies, if a failure of such components can reasonably be expected to cause the failure of that life-support device or system or to affect the safety or effectiveness of that device or system. Life support devices or systems are intended to be implanted in the human body or to support and/or maintain and sustain and/or protect human life. If they fail, it is reasonable to assume that the health of the user or other persons may be endangered.

**Revision History**

Page or Item	Subjects (major changes since previous revision)
<b>&lt;Revision 0.86&gt;, 15.05.2014</b>	
all	change term VCC in VDD
<b>&lt;Revision 2.2&gt;, 01.06.2016</b>	
Update maximum Ta from 95°C to 105°C in Table 5	

**Trademarks of Infineon Technologies AG**

AURIX™, BlueMoon™, C166™, CanPAK™, CIPOS™, CIPURSE™, COMNEON™, EconoPACK™, CoolMOS™, CoolSET™, CORECONTROL™, CROSSAVE™, DAVE™, EasyPIM™, EconoBRIDGE™, EconoDUAL™, EconoPIM™, EiceDRIVER™, eupec™, FCOS™, HITFET™, HybridPACK™, I²RF™, ISOFACE™, IsoPACK™, MIPAQ™, ModSTACK™, my-d™, NovalithIC™, OmniTune™, OptiMOS™, ORIGA™, PRIMARION™, PrimePACK™, PrimeSTACK™, PRO-SIL™, PROFET™, RASIC™, ReverSave™, SatRIC™, SIEGET™, SINDRION™, SIPMOS™, SMARTi™, SmartLEWIS™, SOLID FLASH™, TEMPFET™, thinQ!™, TRENCHSTOP™, TriCore™, X-GOLD™, X-PMU™, XMM™, XPOSYS™.

**Other Trademarks**

Advance Design System™ (ADS) of Agilent Technologies, AMBA™, ARM™, MULTI-ICE™, KEIL™, PRIMECELL™, REALVIEW™, THUMB™, µVision™ of ARM Limited, UK. AUTOSAR™ is licensed by AUTOSAR development partnership. Bluetooth™ of Bluetooth SIG Inc. CAT-iq™ of DECT Forum. COLOSSUS™, FirstGPS™ of Trimble Navigation Ltd. EMV™ of EMVCo, LLC (Visa Holdings Inc.). EPCOS™ of Epcos AG. FLEXGO™ of Microsoft Corporation. FlexRay™ is licensed by FlexRay Consortium. HYPERTERMINAL™ of Hilgraeve Incorporated. IEC™ of Commission Electrotechnique Internationale. IrDA™ of Infrared Data Association Corporation. ISO™ of INTERNATIONAL ORGANIZATION FOR STANDARDIZATION. MATLAB™ of MathWorks, Inc. MAXIM™ of Maxim Integrated Products, Inc. MICROTEC™, NUCLEUS™ of Mentor Graphics Corporation. Mifare™ of NXP. MIPI™ of MIPI Alliance, Inc. MIPS™ of MIPS Technologies, Inc., USA. muRata™ of MURATA MANUFACTURING CO., MICROWAVE OFFICE™ (MWO) of Applied Wave Research Inc., OmniVision™ of OmniVision Technologies, Inc. Openwave™ Openwave Systems Inc. RED HAT™ Red Hat, Inc. RFMD™ RF Micro Devices, Inc. SIRIUS™ of Sirius Satellite Radio Inc. SOLARIS™ of Sun Microsystems, Inc. SPANSION™ of Spansion LLC Ltd. Symbian™ of Symbian Software Limited. TAIYO YUDEN™ of Taiyo Yuden Co. TEAKLITE™ of CEVA, Inc. TEKTRONIX™ of Tektronix Inc. TOKO™ of TOKO KABUSHIKI KAISHA TA. UNIX™ of X/Open Company Limited. VERILOG™, PALLADIUM™ of Cadence Design Systems, Inc. VLYNQ™ of Texas Instruments Incorporated. VXWORKS™, WIND RIVER™ of WIND RIVER SYSTEMS, INC. ZETEX™ of Diodes Zetex Limited.

Last Trademarks Update 2010-10-26

## Table of Contents

<b>1</b>	<b>Overview .....</b>	<b>7</b>
<b>2</b>	<b>Blockdiagram.....</b>	<b>9</b>
<b>3</b>	<b>Pin configuration, description, and functionality .....</b>	<b>10</b>
3.1	Pin Configuration and Description.....	10
3.2	Low Side and High Side Control Pins (LIN, HIN) .....	10
3.2.1	Input voltage range .....	10
3.2.2	Switching levels.....	10
3.2.3	Input filter time.....	11
3.3	VDD, GND and PGND (Low Side Supply) .....	11
3.4	VB and VS (High Side Supplies).....	11
3.5	LO and HO (Low and High Side Outputs).....	11
3.6	Undervoltage lockout (UVLO) .....	12
3.7	Bootstrap diode .....	12
3.8	Deadtime and interlock function .....	12
3.9	EN-/FLT (fault indication and enable function).....	12
3.10	Power ground / over current protection.....	13
<b>4</b>	<b>Electrical Parameters.....</b>	<b>14</b>
4.1	Absolute Maximum Ratings .....	14
4.2	Required operation conditions .....	15
4.3	Operating Range .....	15
4.4	Static logic function table .....	16
4.5	Static parameters .....	16
4.6	Dynamic parameters .....	18
<b>5</b>	<b>Timing diagrams.....</b>	<b>19</b>
<b>6</b>	<b>Package.....</b>	<b>22</b>
6.1	PG-DSO-14 .....	22

## List of Figures

Figure 1	Typical Application .....	8
Figure 2	Block diagram for 2EDL23x06PJ .....	9
Figure 3	Pin Configuration of 2EDL family .....	10
Figure 4	Input pin structure.....	11
Figure 5	Input filter timing diagram .....	11
Figure 6	EN-/FLT pin structures and interface to microcontroller (μC) .....	12
Figure 7	Timing of short pulse suppression .....	19
Figure 8	Timing of of internal deadtime.....	19
Figure 9	Enable delay time definition .....	19
Figure 10	Input to output propagation delay times and switching times definition.....	20
Figure 11	Operating areas (IGBT UVLO levels).....	20
Figure 12	Operating areas (MOSFET UVLO levels) .....	20
Figure 13	ITRIP-Timing .....	21
Figure 14	Output pulse width timing and matching delay timing diagram for positive logic.....	21
Figure 15	Package drawing.....	22
Figure 16	PCB reference layout (according to JEDEC 1s0P) left: Reference layout right: detail of footprint....	22

## List of Tables

Table 1	Members of 2EDL family .....	7
Table 2	Pin Description .....	10
Table 3	Abs. maximum ratings .....	14
Table 4	Required Operation Conditions .....	15
Table 5	Operating range .....	15
Table 6	Static parameters .....	16
Table 7	Dynamic parameters .....	18
Table 8	Data of reference layout .....	22

## EiceDRIVER™ Compact 600 V half bridge gate drive IC

### 1 Overview

#### Main features

- Thin-film-SOI-technology
- Maximum blocking voltage +600V
- Individual control circuits for both outputs
- Filtered detection of under voltage supply
- All inputs clamped by diodes
- Active shut down function
- Asymmetric undervoltage lockout thresholds for high side and low side
- Qualified according to JEDEC<sup>1</sup> (high temperature stress tests for 1000h) for target applications



#### Product highlights

- Insensitivity of the bridge output to negative transient voltages up to -50V given by SOI-technology
- Ultra fast bootstrap diode
- Overcurrent comparator
- Enable function, Fault indicator

#### Typical applications

- Home appliances
- Consumer electronics
- Fans, pumps
- General purpose drives

#### Product family

**Table 1** Members of 2EDL family

Sales Name	Special function	output current	Target transistor	typ. LS UVLO-thresholds	Bootstrap diode	Package
2EDL23I06PJ	deadtime, interlock, Enable, Fault, OCP	2.3 A	IGBT	12.5 V / 11.6 V	Yes	DSO-14
2EDL23N06PJ	deadtime, interlock, Enable, Fault, OCP	2.3 A	MOSFET	9.1 V / 8.3 V	Yes	DSO-14

<sup>1</sup> J-STD-020 and JESD-022





## 2 Blockdiagram

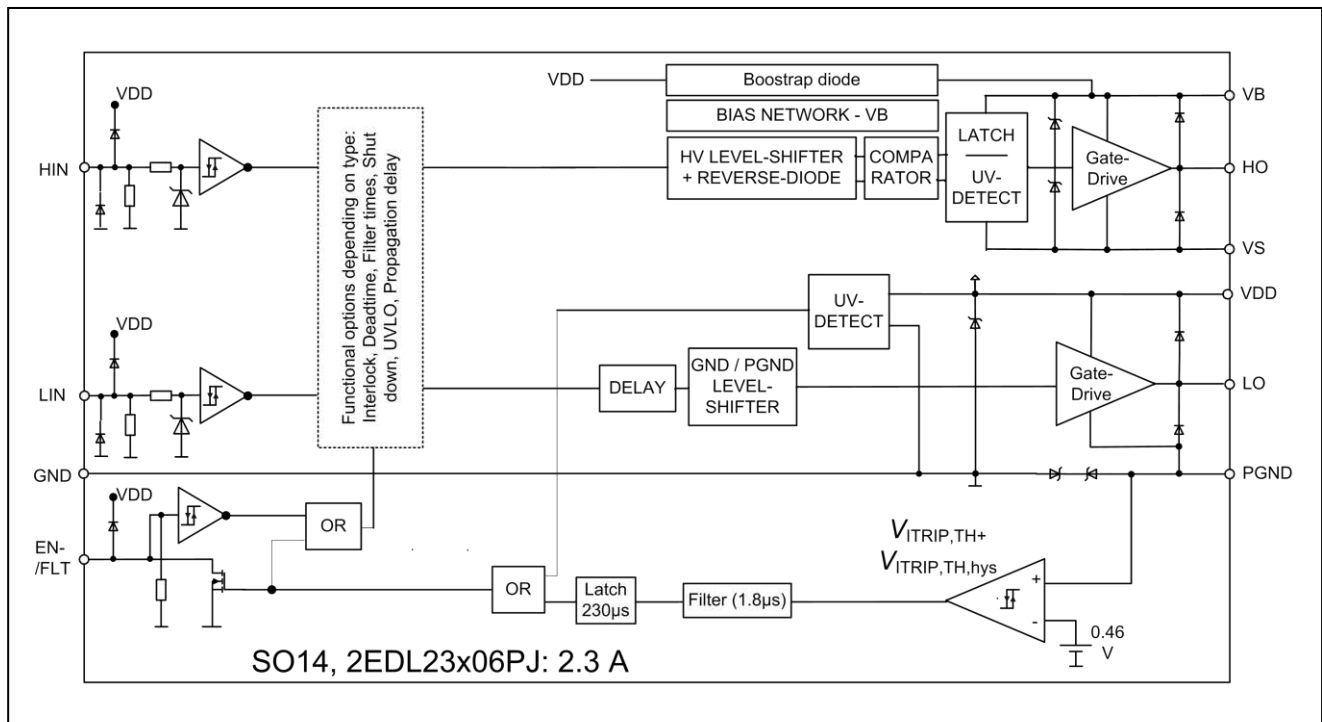

Figure 2 Block diagram for 2EDL23x06PJ

### 3 Pin configuration, description, and functionality

#### 3.1 Pin Configuration and Description

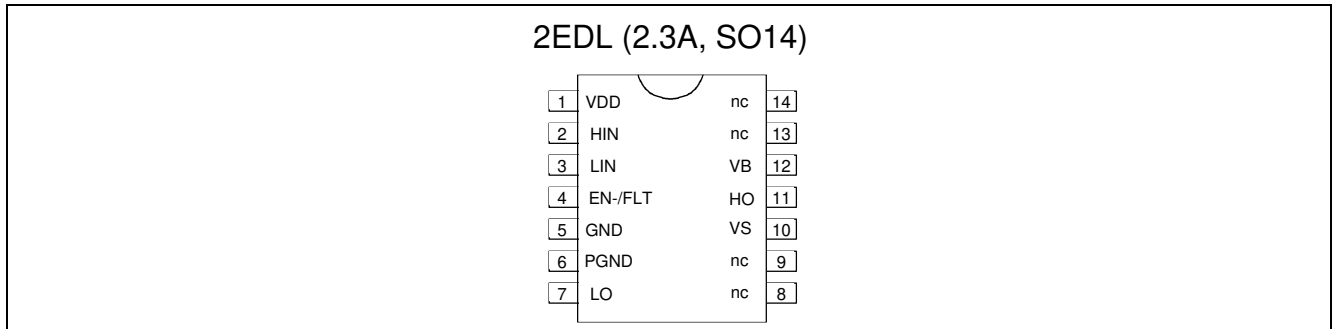

Figure 3 Pin Configuration of 2EDL family

Table 2 Pin Description

Symbol	Description
VDD	Low side power supply
GND	Logic ground
HIN	High side logic input
LIN	Low side logic input
EN-/FLT	Enable input and Fault indication output
PGND	Low side gate driver reference
VB	High side positive power supply
HO	High side gate driver output
VS	High side negative power supply
LO	Low side gate driver output
nc	Not Connected

#### 3.2 Low Side and High Side Control Pins (LIN, HIN)

##### 3.2.1 Input voltage range

All input pins have the capability to process input voltages up to the supply voltage of the IC. The inputs are therefore internally clamped to VDD and GND by diodes. An internal pull-down resistor is high ohmic, so that it can keep the IC in a safe state in case of PCB crack.

##### 3.2.2 Switching levels

The Schmitt trigger input threshold is such to guarantee LSTTL and CMOS compatibility down to 3.3 V controller outputs. The input Schmitt trigger and noise filter provide beneficial noise rejection to short input pulses according to Figure 4 and Figure 5. Please note, that the switching levels of the input structures remain constant even though they can accept amplitudes up to the IC supply level.

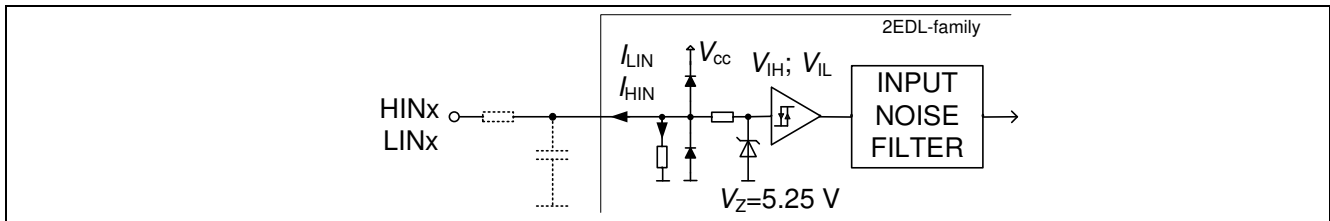

Figure 4 Input pin structure

### 3.2.3 Input filter time

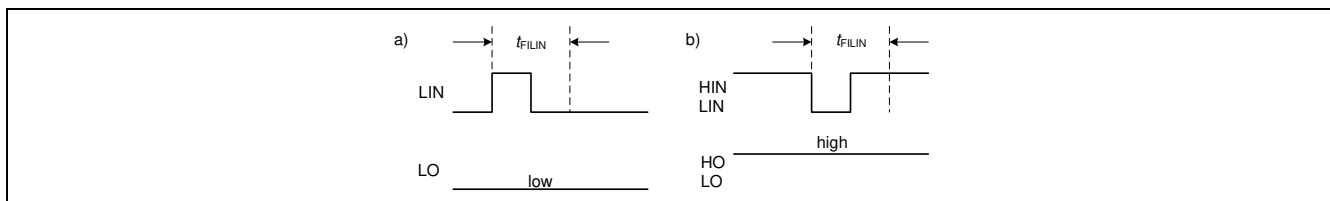

Figure 5 Input filter timing diagram

Short pulses are suppressed by means of an input filter. The MOSFET version (2EDL23N06PJ) has an input filter time of  $t_{FILIN} = 100$  ns typ. for high side and 150ns typ. for low side. The IGBT version (2EDL23I06PJ) has filter times of 190ns typ.

### 3.3 VDD, GND and PGND (Low Side Supply)

VDD is the low side supply and it provides power to both the input logic and the low side output power stage. The input logic is referenced to GND ground as well as the under-voltage detection circuit. Output power stage is referenced to PGND ground. PGND ground is floating respect to GND ground with an absolute maximum range of operation of +/-5.7 V. A back-to-back zener structure protects grounds from noise spikes.

The undervoltage lockout circuit enables the device to operate at power on when a typical supply voltage higher than  $V_{DDUV+}$  is present. Please see section 3.6 “Undervoltage lockout” for further information.

A filter time of typ.  $1.5 \mu s$  helps to suppress noise from the UVLO circuit, so that negative going voltage spikes at the supply pins will avoid parasitic UVLO events.

### 3.4 VB and VS (High Side Supplies)

VB to VS is the high side supply voltage. The high side circuit can float with respect to GND following the external high side power device emitter/source voltage. Due to the low power consumption, the floating driver stage can be supplied by bootstrap topology connected to VDD. A filter time of typ.  $1.3 \mu s$  helps to suppress noise from the UVLO circuit, so that negative going voltage spikes at the supply pins will avoid parasitic UVLO events.

The under-voltage circuit enables the device to operate at power on when a typical supply voltage higher than  $V_{DDUV+}$  is present. Please see section 3.6 “Undervoltage lockout” for further information. Details on bootstrap supply section and transient immunity can be found in application note [EiceDRIVER™ 2EDL family: Technical description](#).

### 3.5 LO and HO (Low and High Side Outputs)

Low side and high side power outputs are specifically designed for pulse operation such as gate drive for IGBT and MOSFET devices. Low side output is state triggered by the respective inputs, while high side output is edge triggered by the respective inputs. In particular, after an undervoltage condition of the VBS supply, a new turn-on signal (edge) is necessary to activate the high side output. In contrast, the low side outputs switch to the state of their respective inputs after an undervoltage condition of the VDD supply.

The output current specification  $I_{O+}$  and  $I_{O-}$  is defined in a way, which considers the power transistors miller voltage. This helps to design the gate drive better in terms of the application needs. Nevertheless, the devices are also characterised for the value of the pulse short circuit value  $I_{Opk+}$  and  $I_{Opk-}$ .

### 3.6 Undervoltage lockout (UVLO)

Two different UVLO options are required for IGBT and MOSFET. The types 2EDL23I06PJ are designed to drive IGBT. There are higher levels of undervoltage lockout for the low side UVLO than for the high side. This supports an improved start up of the IC, when bootstrapping is used. The thresholds for the low side are typically  $V_{DDUV+} = 12.5\text{ V}$  (positive going) and  $V_{DDUV-} = 11.6\text{ V}$  (negative going). The thresholds for the high side are typically  $V_{BSUV+} = 11.6\text{ V}$  (positive going) and  $V_{BSUV-} = 10.7\text{ V}$  (negative going).

The types 2EDL23N06PJ are designed to drive power MOSFET. A similar distinction for the high side and low side UVLO threshold as for IGBT is not realised here. The IC shuts down all the gate drivers power outputs, when the supply voltage is below typ.  $V_{DDUV-} = 8.3\text{ V}$  (min. / max. =  $7.5\text{ V} / 9\text{ V}$ ). The turn-on threshold is typ.  $V_{DDUV+} = 9.1\text{ V}$  (min. / max. =  $8.3\text{ V} / 9.9\text{ V}$ ).

### 3.7 Bootstrap diode

An ultra fast bootstrap diode is monolithically integrated for establishing the high side supply. The differential resistor of the diode helps to avoid extremely high inrush currents when charging the bootstrap capacitor initially.

### 3.8 Deadtime and interlock function

The IC provides a hardware fixed deadtime. The deadtime is different for the MOSFET type (2EDL23N06PJ) and for the IGBT type (2EDL23I06PJ). The deadtimes are particularly typ. 380 ns for IGBT and typ. 75 ns for MOSFET. An additional interlock function prevents the two outputs from being activated simultaneously.

### 3.9 EN-/FLT (fault indication and enable function)

The types 2EDL23x06PJ provide a pin, which can either be used to shut down the IC or to read out a failure status of the IC. The signal applied to pin EN controls directly the output stages. All outputs are set to LOW, if EN is at LOW logic level. An integrated pull down resistor shuts down the IC in case of a floating input. The internal structure of the pin is given in Figure 6. The switching levels of the Schmitt-Trigger are here  $V_{EN,TH+} = 2.1\text{ V}$  and  $V_{EN,TH-} = 0.9\text{ V}$ . The typical propagation delay time is  $t_{EN} = 550\text{ ns}$ . The input is clamped by diodes to VDD and GND. The input voltage range is the same as the input control pins with a max. of 20 V.

The /FAULT function is an active low open-drain output indicating the status of the gate driver (see Figure 6). The pin is active (i.e. forces LOW voltage level) when one of the following conditions occur:

- Under-voltage condition of VDD supply: In this case the fault condition is released as soon as the supply voltage condition returns in the normal operation range (please refer to VDD pin description for more details). The fault signal is activate as long as UVLO is given during power up.
- Overcurrent detection (ITRIP): The fault condition is latched until the overcurrent trigger condition is finished and additional typ. 230  $\mu\text{s}$  are elapsed.

The interface to the microcontroller can be realised by using an open collector / drain configured output pin for enabling the driver IC and a GPIO pin for monitoring the /FAULT. The external pull-up resistor will pull-up the voltage to +5V, when the IC is set for operation.

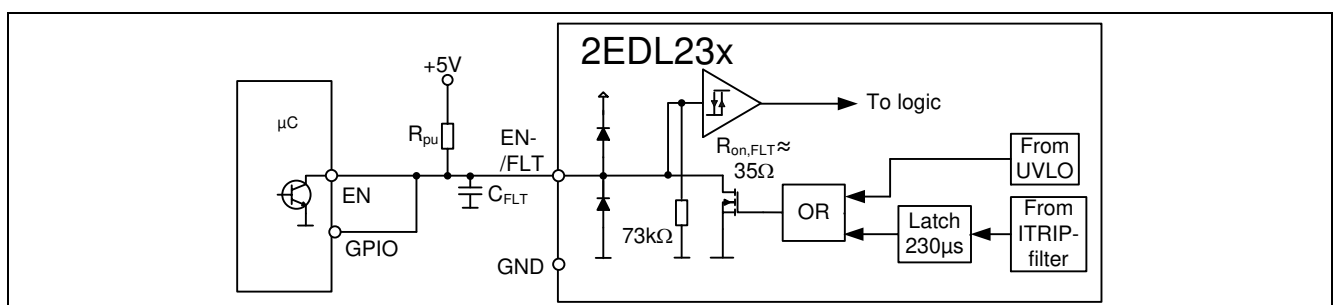

Figure 6 EN-/FLT pin structures and interface to microcontroller ( $\mu\text{C}$ )

### 3.10 Power ground / over current protection

A power ground (PGND) connects directly the emitter or source of the low side transistor with the gate drive IC. No other components, such as shunts, etc., are between this connection and the emitter or source. This enables the routing of smallest gate circuit loops and therefore smallest gate inductances.

A potential shunt resistor is between the power ground (PGND) connection and the ground connection (GND), which leads to a voltage drop between these two pins.

The voltage drop between PGND and GND can be sensed by means of a comparator with a threshold of  $V_{th,ITRIP} = 0.46$  V. If the voltage drop is larger than  $V_{th,ITRIP}$ , then the output of the comparator is triggered and the /FLT output is activated. Simultaneously, the IC shuts down both gate outputs for the period of the fault indication, which is 230  $\mu$ s.

Several influences, such as reverse recovery currents, parasitic inductances and other noise sources, make the need of a signal filter necessary. The filter has a time constant of typically 1.8  $\mu$ s to ensure good noise quality.

---

<sup>1</sup> Not subject of production test, verified by characterisation

## 4 Electrical Parameters

### 4.1 Absolute Maximum Ratings

All voltages are absolute voltages referenced to  $V_{GND}$  -potential unless otherwise specified. ( $T_a=25^\circ\text{C}$ )

**Table 3 Abs. maximum ratings**

Parameter	Symbol	Min.	Max.	Unit
High side offset voltage(Note 1)	$V_S$	$V_{DD}-V_{BS}-6$	600	V
High side offset voltage ( $t_p<500\text{ns}$ , Note 1)		$V_{DD}-V_{BS}-50$	–	
High side offset voltage(Note 1)	$V_B$	$V_{DD}-6$	620	
High side offset voltage ( $t_p<500\text{ns}$ , Note 1)		$V_{DD}-50$	–	
High side floating supply voltage ( $V_B$ vs. $V_S$ ) (internally clamped)	$V_{BS}$	-1	20	
High side output voltage ( $V_{HO}$ vs. $V_S$ )	$V_{HO}$	-0.5	$V_B + 0.5$	
Low side supply voltage (internally clamped)	$V_{DD}$	-1	20	
Low side supply voltage ( $V_{DD}$ vs. $V_{PGND}$ )	$V_{DDPGND}$	-0.5	25	
Gate driver ground	$V_{PGND}$	-5.7	5.7	
Low side output voltage ( $V_{LO}$ vs. $V_{PGND}$ )	$V_{LO}$	-0.5	$V_{DDPGND} + 0.5$	
Input voltage LIN,HIN,EN	$V_{IN}$	-0.5	$V_{DD} + 0.5$	
FAULT output voltage	$V_{FLT}$	-0.5	$V_{DD} + 0.5$	
Power dissipation (to package) (Note 2)	$P_D$	–	0.9	W
Thermal resistance (junction to ambient, see section 6)	$R_{th(j-a)}$	–	134	K/W
Junction temperature (Note 3)	$T_J$	–	150	°C
Storage temperature	$T_S$	- 40	150	
offset voltage slew rate (Note 4)	$dV_S/dt$	–	50	V/ns

Note :The minimum value for ESD immunity is 1.0kV (Human Body Model). ESD immunity inside pins connected to the low side ( $V_{DD}$ , HIN, LIN, FAULT, EN, GND, PGND, LO) and pins connected inside each high side itself ( $V_B$ , HO, VS) is guaranteed up to 1.5kV (Human Body Model) respectively.

Note 1 : In case  $V_{DD} > V_B$  there is an additional power dissipation in the internal bootstrap diode between pins  $V_{DD}$  and  $V_B$  in case of activated bootstrap diode. Insensitivity of bridge output to negative transient voltage up to  $-50\text{V}$  is not subject to production test – verified by design / characterization.

Note 2: Consistent power dissipation of all outputs. All parameters are inside operating range.

Note 3: Qualification stress tests cover a max. junction temperature of  $150^\circ\text{C}$  for 1000 h.

Note 4: Not subject of production test, verified by characterisation.

## 4.2 Required operation conditions

All voltages are absolute voltages referenced to  $V_{GND}$  -potential unless otherwise specified. ( $T_a = 25^\circ\text{C}$ )

**Table 4 Required Operation Conditions**

Parameter	Symbol	Min.	Max.	Unit
High side offset voltage (Note 1)	$V_B$	7	620	V
Low side supply voltage ( $V_{DD}$ vs. $V_{PGND}$ )	$V_{DDPGND}$	10	25	

## 4.3 Operating Range

All voltages are absolute voltages referenced to  $V_{GND}$  -potential unless otherwise specified. ( $T_a = 25^\circ\text{C}$ )

**Table 5 Operating range**

Parameter	Symbol	Min.	Max.	Unit	
High side floating supply offset voltage	$V_S$	$V_{DD} - V_{BS} - 1$	500	V	
High side floating supply offset voltage ( $V_B$ vs. $V_{DD}$ , statically)	$V_{BDD}$	-1.0	500		
High side floating supply voltage ( $V_B$ vs. $V_S$ , Note 1)	IGBT-Types	$V_{BS}$	13	17.5	
	MOSFET-Types		10	17.5	
High side output voltage ( $V_{HO}$ vs. $V_S$ )	$V_{HO}$	10	$V_{BS}$		
Low side output voltage ( $V_{LO}$ vs. $V_{PGND}$ )	$V_{LO}$	0	$V_{DD}$		
Low side supply voltage	IGBT-Types	$V_{DD}$	13	17.5	
	MOSFET-Types		10	17.5	
Low side ground voltage	$V_{PGND}$	-2.5	2.5		
Logic input voltages LIN,HIN,EN (Note 2)	$V_{IN}$	0	17.5		
FAULT output voltage	$V_{FLT}$	0	$V_{DD}$		
Pulse width for ON or OFF (Note 3)	IGBT-Types	$t_{IN}$	0.8	–	$\mu\text{s}$
	MOSFET-Types		0.3	–	
Ambient temperature	$T_a$	-40	105	$^\circ\text{C}$	
Thermal resistance (junction to ambient, see section 6)	DSO8	$\Psi_{th(j-top)}$	–	4.8	K/W
	DSO14		–	3.3	

Note 1 : Logic operational for  $V_B$  ( $V_B$  vs.  $V_{GND}$ ) > 7.0V

Note 2 : All input pins (HIN, LIN) and EN pin are internally clamped (see abs. maximum ratings)

Note 3 : The input pulse may not be transmitted properly in case of input pulse width at LIN and HIN below 0.8 $\mu\text{s}$  (IGBT types) or 0.3  $\mu\text{s}$  (MOSFET) respectively



#### 4.4 Static logic function table

VDD	VBS	ENABLE	FAULT	PGND	LO	HO
$<V_{DDUV-}$	X	X	0	X	0	0
15V	$<V_{BSUV-}$	3.3 V	High imp.	$< V_{th,ITRIP}$	LIN	0
15V	15V	3.3 V	0	$> V_{th,ITRIP}$	0	0
15V	15V	0 V	High imp.	X	0	0
15V	15V	3.3 V	High imp.	$< V_{th,ITRIP}$	LIN	HIN

All voltages with reference to GND

#### 4.5 Static parameters

$V_{DD} = V_{BS} = 15V$  unless otherwise specified. ( $T_a = 25^\circ C$ ) and  $V_{GND} = V_{PGND}$  unless otherwise specified

**Table 6** Static parameters

Parameter	Symbol	Values			Unit	Test condition
		Min.	Typ.	Max.		
High level input voltage	$V_{IH}$	1.7	2.1	2.4	V	
Low level input voltage	$V_{IL}$	0.7	0.9	1.1		
EN positive going threshold	$V_{EN,TH+}$	1.7	2.1	2.4		
EN negative going threshold	$V_{EN,TH-}$	0.7	0.9	1.1		
High level output voltage	LO $V_{OH}$	–	$V_{DD}-0.32$	$V_{DD}-0.7$		$I_O = -100\text{ mA}$
	HO $V_{OH}$	–	$V_B-0.32$	$V_B-0.7$		
High level output voltage	LO $V_{OL}$	–	$V_{PGND}+0.18$	$V_{PGND}-0.4$		$I_O = 100\text{ mA}$
	HO $V_{OL}$	–	$V_S+0.18$	$V_S+0.4$		
$V_{DD}$ supply undervoltage positive going threshold	IGBT-types $V_{DDUV+}$	11.8	12.5	13.2		
	MOSFET types $V_{DDUV+}$	8.3	9.1	9.9		
$V_{BS}$ supply undervoltage positive going threshold	IGBT-types $V_{BSUV+}$	10.9	11.6	12.4		
	MOSFET types $V_{BSUV+}$	8.3	9.1	9.9		
$V_{DD}$ supply undervoltage negative going threshold	IGBT-types $V_{DDUV-}$	10.9	11.6	12.4		
	MOSFET types $V_{DDUV-}$	7.5	8.3	9		
$V_{BS}$ supply undervoltage negative going threshold	IGBT-types $V_{BSUV-}$	10	10.7	11.7		
	MOSFET types $V_{BSUV-}$	7.5	8.3	9		
$V_{DD}$ and $V_{BS}$ supply UVLO hysteresis	IGBT-types $V_{DDUVH}$	0.5	0.9	–		
	MOSFET types $V_{BSUVH}$	0.5	0.9	–		
ITRIP comparator threshold	$V_{th,ITRIP}$	0.4	0.46	0.53	$V_{ITRIP} = V_{PGND} - V_{GND}$	
ITRIP comparator hysteresis	$V_{th,ITRIP\ hys}$	0.045	0.07	–		
High side leakage current betw. VS and GND	$I_{LVS+}$	–	1	12.5	$\mu A$	$V_S = 600V$
High side leakage current betw. VS and GND	$I_{LVS+}^1$	–	10	–		$T_J = 125^\circ C,$ $V_S = 600\text{ V}$

<sup>1</sup> Not subject of production test, verified by characterisation

**Table 6 Static parameters**

Parameter	Symbol	Values			Unit	Test condition
		Min.	Typ.	Max.		
Quiescent current $V_{BS}$ supply (VB only)	$I_{QBS1}$	–	180	300		HO = low depending on current types
Quiescent current $V_{BS}$ supply (VB only)	$I_{QBS2}$	–	180	300		HO = high depending on current types
Quiescent current VDD supply (VDD only)	$I_{QDD1}$	–	0.34	0.8	mA	$V_{LIN} = \text{float}$
Quiescent current VDD supply (VDD only)	$I_{QDD2}$	–	0.32	0.8		$V_{LIN} = 3.3 \text{ V}, V_{HIN} = 0$
Quiescent current VDD supply (VDD only)	$I_{QDD3}$	–	0.32	0.8		$V_{LIN} = 0, V_{HIN} = 3.3 \text{ V}$
Input bias current	$I_{LIN+}$	15	35	60	$\mu\text{A}$	$V_{LIN} = 3.3 \text{ V}$
Input bias current	$I_{LIN-}$	–	0	–		$V_{LIN} = 0$
Input bias current	$I_{HIN+}$	15	35	60		$V_{HIN} = 3.3 \text{ V}$
Input bias current	$I_{HIN-}$	–	0	–		$V_{HIN} = 0$
Input bias current (EN=high)	$I_{EN+}$	–	45	100		$V_{ENABLE} = 3.3 \text{ V}$
Mean output current for load capacity charging in range from 4.5 (30%) to 7.5V (50%)	$I_{O+}$	1.3	1.8	–	A	$C_L = 61 \text{ nF}$
Peak output current turn on (single pulse)	$I_{Opk+}^1$	–	2.3	–	A	$R_L = 0 \Omega, t_p < 10 \mu\text{s}$
Mean output current for load capacity discharging in range from 7.5V (50%) to 4.5V (30%)	$I_{O-}$	1.65	2.5	–	A	$C_L = 61 \text{ nF}$
Peak output current turn off (single pulse)	$I_{Opk-}^1$	–	2.8	–	A	$R_L = 0 \Omega, t_p < 10 \mu\text{s}$
Bootstrap diode forward voltage between VDD and VB	$V_{F,BSD}$	–	0.9	1.2	V	$I_F = 0.3 \text{ mA}$
Bootstrap diode forward current between VDD and VB	$I_{F,BSD}$	45	82	120	mA	$V_{DD} - V_B = 4 \text{ V}$
Bootstrap diode resistance	$R_{BSD}$	15	27	40		$V_{F1} = 4 \text{ V}, V_{F2} = 5 \text{ V}$
EN-/FLT low on resistance of the pull down transistor	$R_{on,FLT}$	–	35	70		$V_{EN-/FLT} = 0.5 \text{ V}$

<sup>1</sup> Not subject of production test, verified by characterisation

## 4.6 Dynamic parameters

$V_{DD} = V_{BS} = 15\text{ V}$ ,  $V_S = V_{GND} = V_{PGND}$ ,  $C_L = 180\text{ pF}$  unless otherwise specified. ( $T_A=25^\circ\text{C}$ )

**Table 7 Dynamic parameters**

Parameter	Symbol	Values			Unit	Test condition	
		Min.	Typ.	Max.			
Turn-on propagation delay	IGBT types	$t_{on}$	280	420	610	ns	$V_{LIN/HIN} = 0$ or 3.3 V
	MOSFET types		210	310	460		
Turn-off propagation delay	IGBT types	$t_{off}$	260	400	590		
	MOSFET types		200	300	440		
Turn-on rise time		$t_r$	–	48	80		$V_{LIN/HIN} = 0$ or 3.3 V
Turn-off fall time		$t_f$	–	37	60		$C_L = 4.9\text{ nF}$
Shutdown propagation delay ENABLE		$t_{EN}$	–	550	850		$V_{EN}=0.5\text{ V}$ , $V_{LO} / V_{HO} = 20\%$
Input filter time at LIN/HIN for turn on and off	IGBT types	$t_{FILIN}$	120	190	320		$V_{LIN/HIN} = 0$ & 3.3 V
	MOSFET types HIN LIN		50 100	100 150	170 250		
Input filter time EN		$t_{FILEN}$	200	400	–		
ITRIP filter time		$t_{FILITRIP}$	1.0	1.8	2.7	$\mu\text{s}$	$V_{PGND} = 1\text{ V}$ , /FLT=0
Shut down propagation delay PGND to any output		$t_{ITRIP}$	1.1	2.2	3.0		$V_{PGND} = 1\text{ V}$ $V_{LO} / V_{HO} = 3\text{ V}$
Propagation delay ITRIP to FAULT		$t_{FLT}$	1.0	2.1	2.9		$V_{PGND} = 1\text{ V}$ , /FLT=0.5 V
Fault-clear time		$t_{FLTCLR}$	70	230	–		$V_{PGND} = 0.1\text{ V}$ , /FLT=2.1 V
Dead time	IGBT types	DT	260	380	540	ns	$V_{LIN/HIN} = 0$ & 3.3 V
	MOSFET types		30	75	140		
Dead time matching abs(DT_LH – DT_HL) for single IC	IGBT types	MDT	–	10	80		ext. dead time 0ns
	MOSFET types		–	10	50		
Matching delay ON, abs(ton_HS - ton_LS)		$MT_{ON}$	–	10	60		external dead time > 500 ns
Matching delay OFF, abs(toff_HS - toff_LS)		$MT_{OFF}$	–	10	60		external dead time >500 ns
Output pulse width matching. $PW_{in} - PW_{out}$	IGBT types	PM	–	20	80		$PW_{in} > 1\text{ }\mu\text{s}$
	MOSFET types		–	20	70		

## 5 Timing diagrams

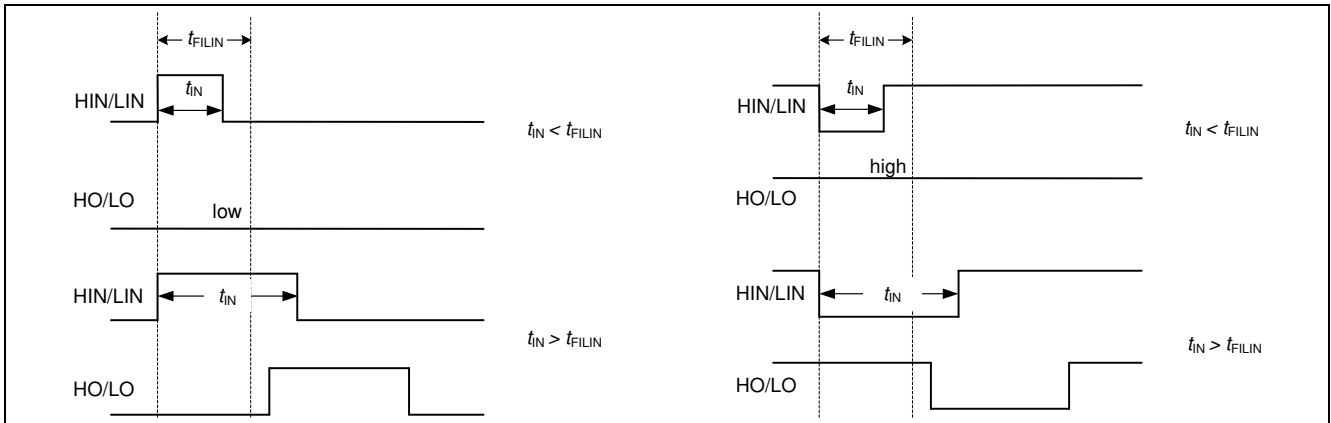

**Figure 7** Timing of short pulse suppression

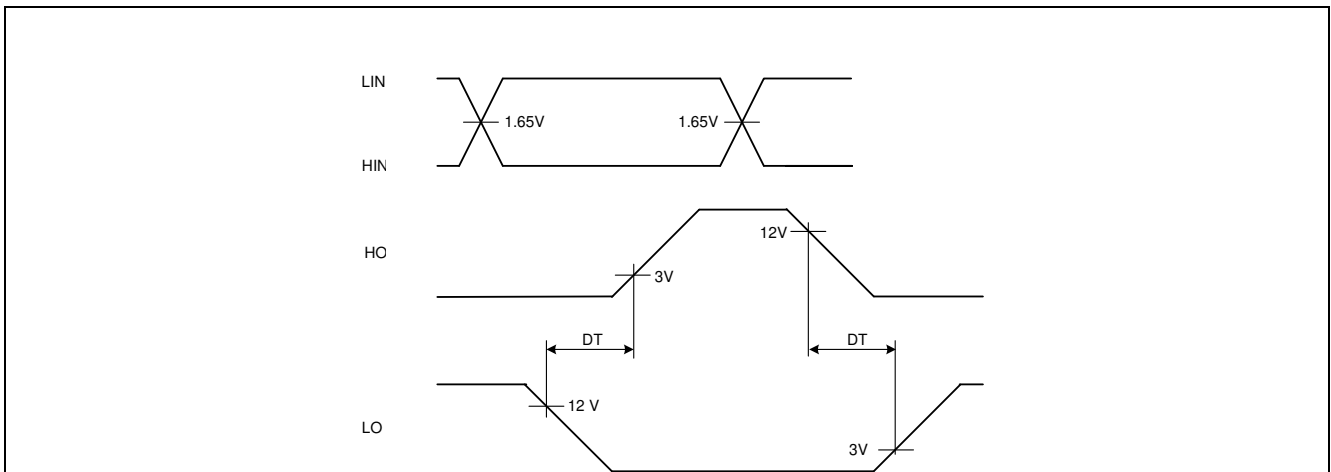

**Figure 8** Timing of of internal deadtime

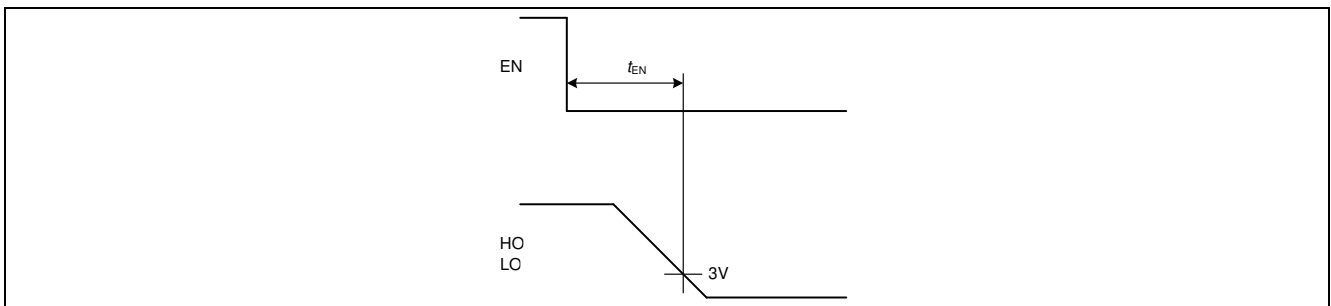

**Figure 9** Enable delay time definition

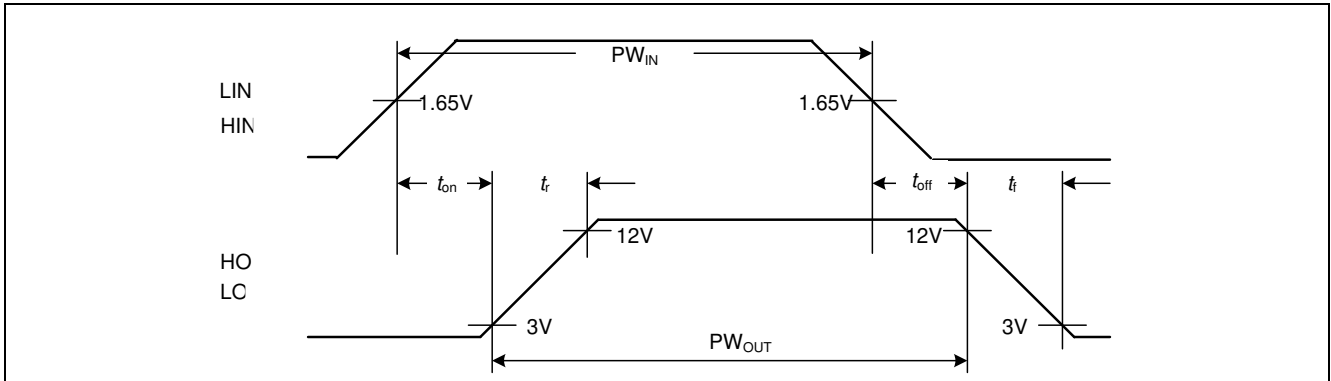

Figure 10 Input to output propagation delay times and switching times definition

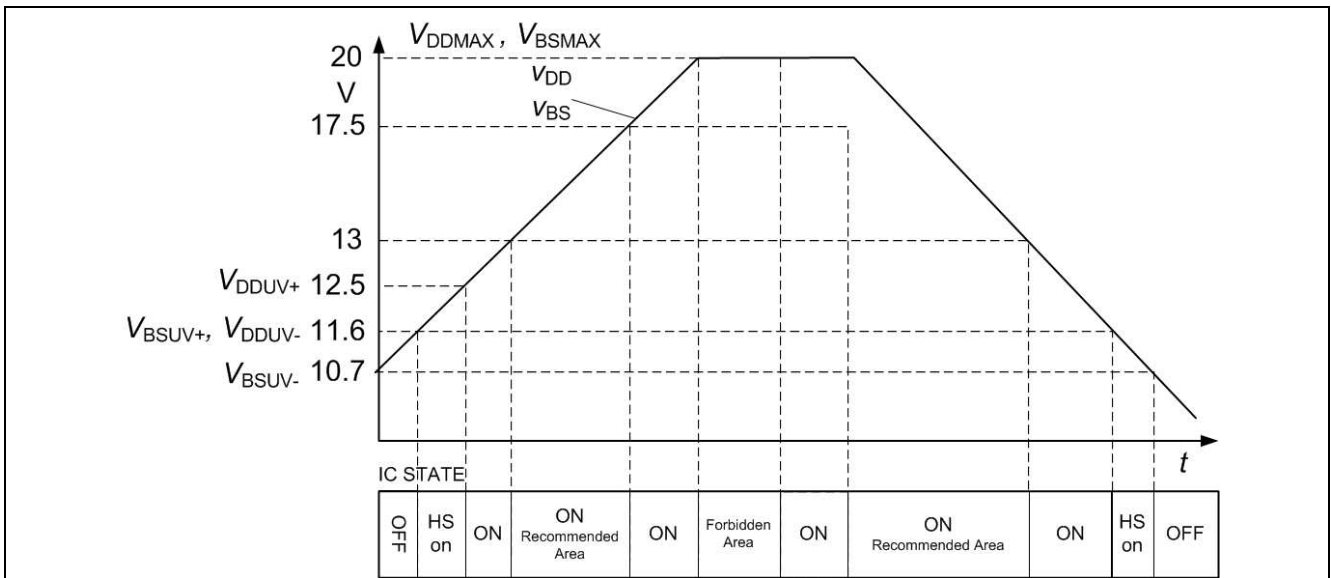

Figure 11 Operating areas (IGBT UVLO levels)

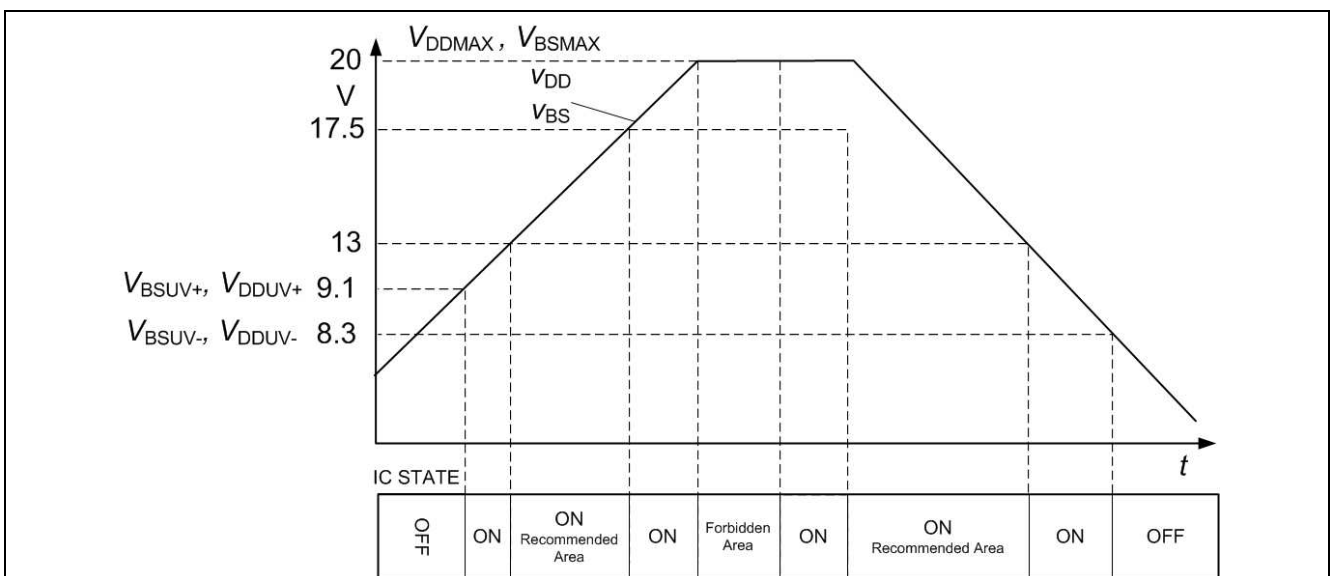

Figure 12 Operating areas (MOSFET UVLO levels)

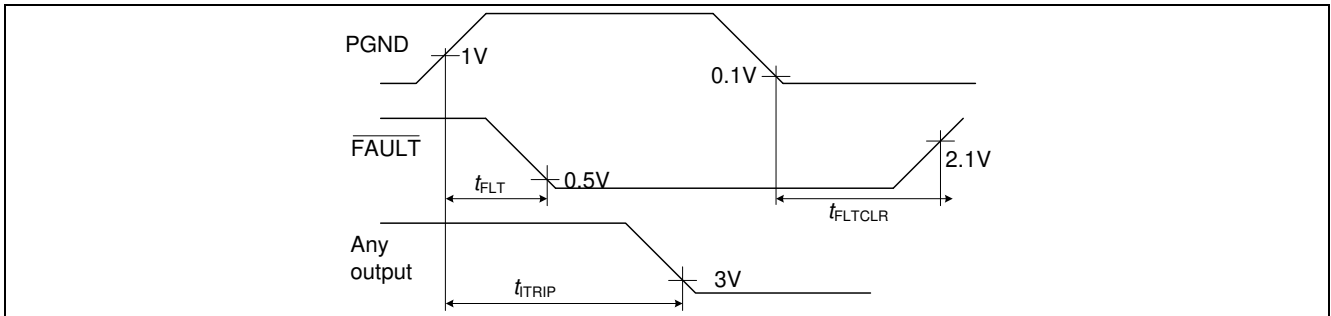

Figure 13 ITRIP-Timing

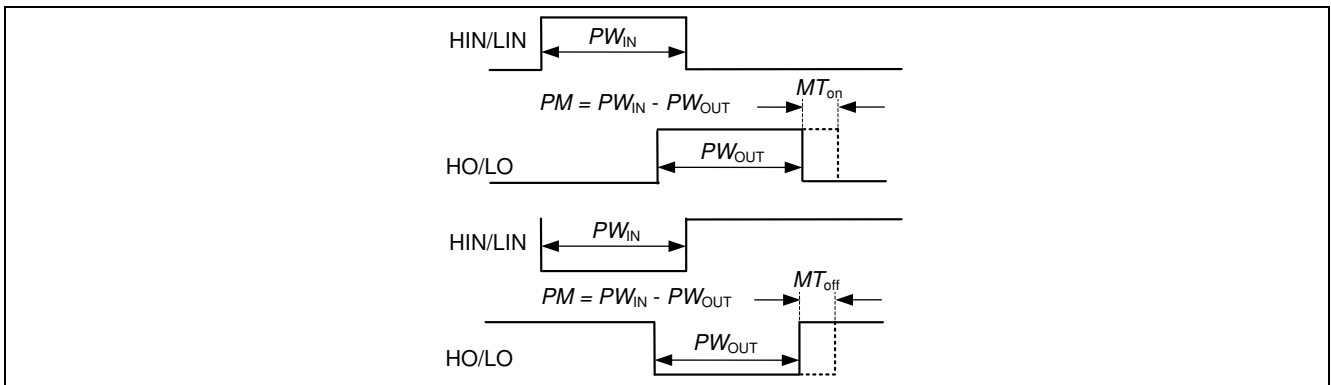

Figure 14 Output pulse width timing and matching delay timing diagram for positive logic

## 6 Package

### 6.1 PG-DSO-14

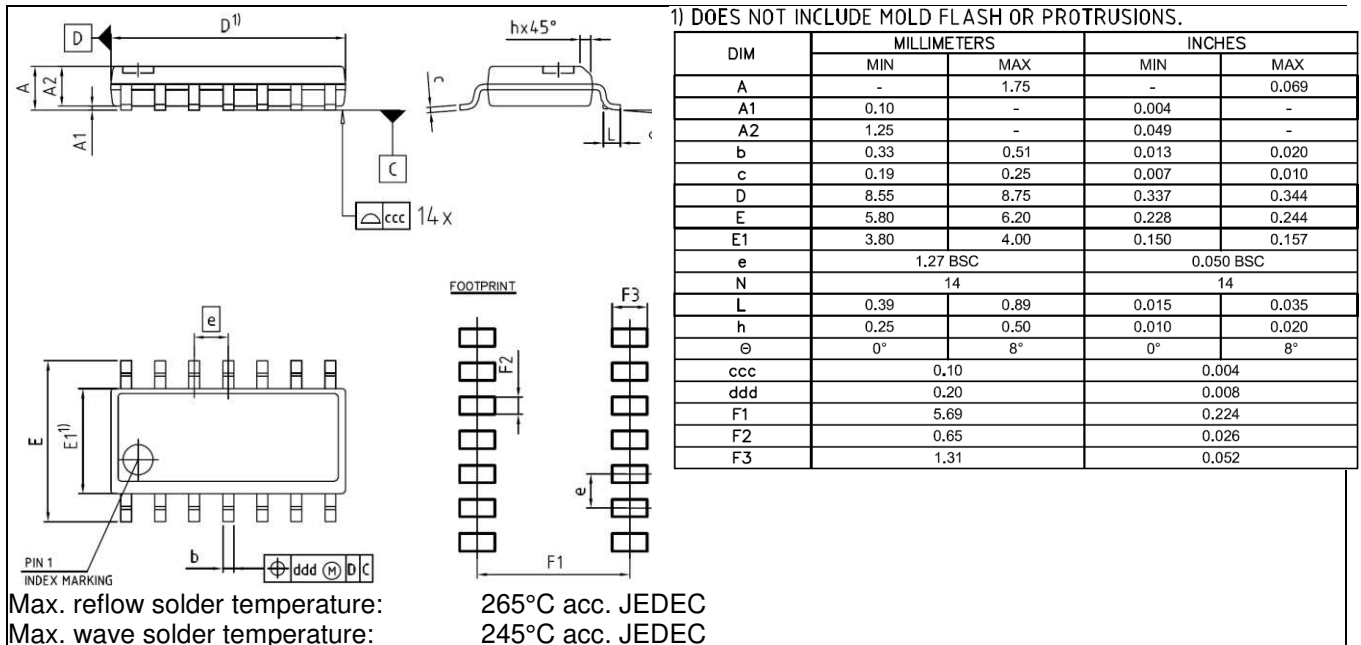

Figure 15 Package drawing

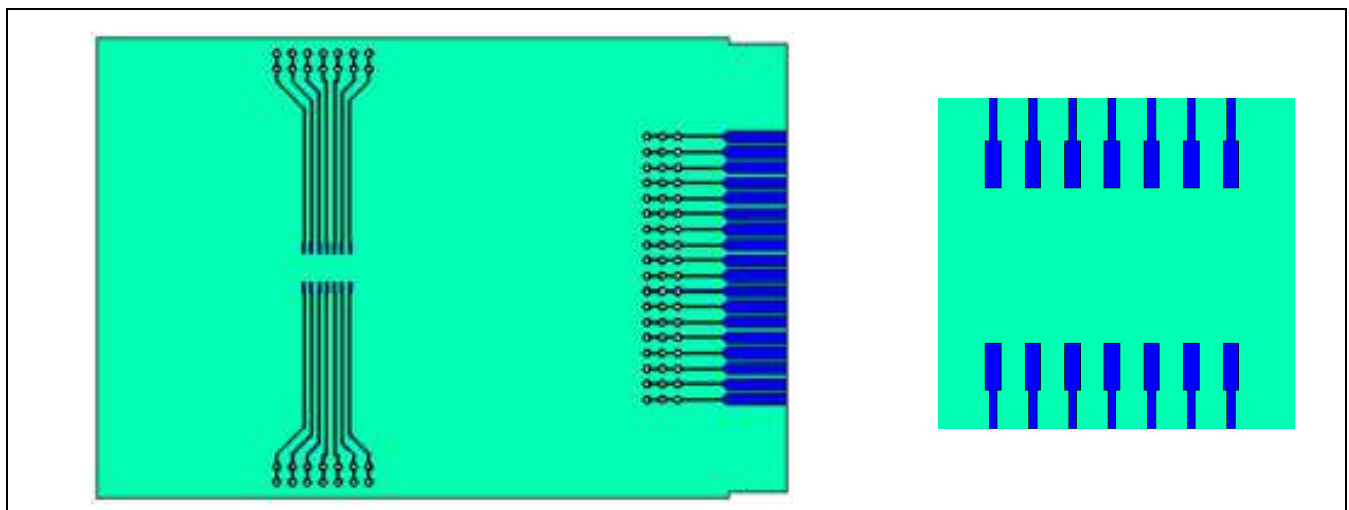

Figure 16 PCB reference layout (according to JEDEC 1s0P)  
left: Reference layout  
right: detail of footprint

The thermal coefficient is used to calculate the junction temperature, when the IC surface temperature is measured. The junction temperature is

$$T_j = \psi_{th(j-top)} \cdot P_d + T_{top}$$

Table 8 Data of reference layout

Dimensions	Material	Metal (Copper)
76.2 × 114.3 × 1.5 mm <sup>3</sup>	FR4 ( $\lambda_{therm} = 0.3$ W/mK)	70µm ( $\lambda_{therm} = 388$ W/mK)

[www.infineon.com](http://www.infineon.com)

Published by Infineon Technologies AG