



Chipsmall Limited consists of a professional team with an average of over 10 year of expertise in the distribution of electronic components. Based in Hongkong, we have already established firm and mutual-benefit business relationships with customers from,Europe,America and south Asia,supplying obsolete and hard-to-find components to meet their specific needs.

With the principle of “Quality Parts,Customers Priority,Honest Operation,and Considerate Service”,our business mainly focus on the distribution of electronic components. Line cards we deal with include Microchip,ALPS,ROHM,Xilinx,Pulse,ON,Everlight and Freescale. Main products comprise IC,Modules,Potentiometer,IC Socket,Relay,Connector.Our parts cover such applications as commercial,industrial, and automotives areas.

We are looking forward to setting up business relationship with you and hope to provide you with the best service and solution. Let us make a better world for our industry!



## Contact us

Tel: +86-755-8981 8866 Fax: +86-755-8427 6832

Email & Skype: info@chipsmall.com Web: www.chipsmall.com

Address: A1208, Overseas Decoration Building, #122 Zhenhua RD., Futian, Shenzhen, China



## SMALL SIGNAL NPN TRANSISTOR

- GENERAL PURPOSE HIGH VOLTAGE DEVICE

### DESCRIPTION

The 2N1893 is a Silicon Planar Epitaxial NPN transistor in Jedec TO-39 metal case, designed for use in high-performance amplifier, oscillator and switching circuits. It provides greater voltage swings in oscillator and amplifier circuits and more protection in inductive switching circuits due to its 120 V collector-to-base voltage rating.

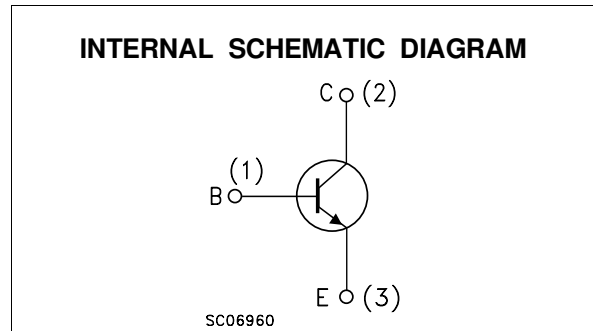
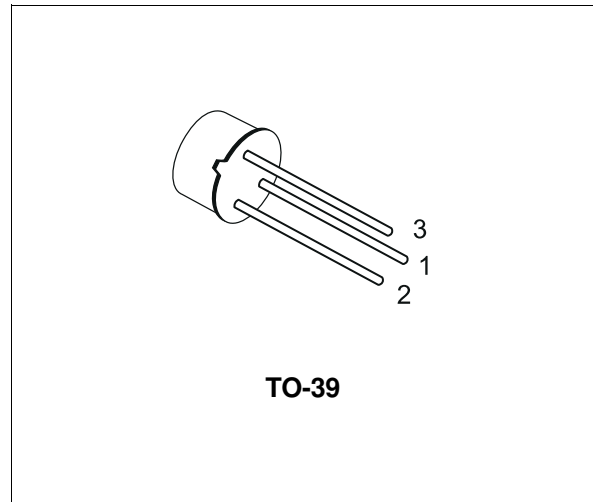

### ABSOLUTE MAXIMUM RATINGS

Symbol	Parameter	Value	Unit
$V_{CBO}$	Collector-Base Voltage ( $I_E = 0$ )	120	V
$V_{CER}$	Collector-Emitter Voltage ( $R_{BE} \leq 10\Omega$ )	100	V
$V_{CEO}$	Collector-Emitter Voltage ( $I_B = 0$ )	80	V
$V_{EBO}$	Emitter-Base Voltage ( $I_C = 0$ )	7	V
$I_C$	Collector Current	0.5	A
$P_{tot}$	Total Dissipation at $T_{amb} \leq 25^\circ\text{C}$	0.8	W
	at $T_C \leq 25^\circ\text{C}$	3	W
	at $T_C \leq 100^\circ\text{C}$	1.7	W
$T_{stg}$	Storage Temperature	-65 to 175	$^\circ\text{C}$
$T_j$	Max. Operating Junction Temperature	175	$^\circ\text{C}$

## THERMAL DATA

R <sub>thj-case</sub>	Thermal Resistance Junction-Case	Max	50	°C/W
R <sub>thj-amb</sub>	Thermal Resistance Junction-Ambient	Max	187.5	°C/W

ELECTRICAL CHARACTERISTICS (T<sub>case</sub> = 25 °C unless otherwise specified)

Symbol	Parameter	Test Conditions	Min.	Typ.	Max.	Unit
I <sub>CBO</sub>	Collector Cut-off Current (I <sub>E</sub> = 0)	V <sub>CB</sub> = 90 V V <sub>CB</sub> = 90 V    T <sub>C</sub> = 150 °C			10 15	nA μA
I <sub>EBO</sub>	Emitter Cut-off Current (I <sub>C</sub> = 0)	V <sub>EB</sub> = 5 V			10	nA
V <sub>(BR)CBO</sub>	Collector-Base Breakdown Voltage (I <sub>E</sub> = 0)	I <sub>C</sub> = 100 μA	120			V
V <sub>(BR)CER*</sub>	Collector-Emitter Breakdown Voltage (R <sub>BE</sub> ≤ 10 Ω)	I <sub>C</sub> = 10 mA	100			V
V <sub>(BR)CEO*</sub>	Collector-Emitter Breakdown Voltage (I <sub>B</sub> = 0)	I <sub>C</sub> = 10 mA	80			V
V <sub>(BR)EBO</sub>	Emitter-Base Breakdown Voltage (I <sub>C</sub> = 0)	I <sub>E</sub> = 100 μA	7			V
V <sub>CE(sat)*</sub>	Collector-Emitter Saturation Voltage	I <sub>C</sub> = 50 mA    I <sub>B</sub> = 5 mA I <sub>C</sub> = 150 mA    I <sub>B</sub> = 15 mA			1.2 5	V V
V <sub>BE(sat)*</sub>	Base-Emitter Saturation Voltage	I <sub>C</sub> = 50 mA    I <sub>B</sub> = 5 mA I <sub>C</sub> = 150 mA    I <sub>B</sub> = 15 mA		0.82 0.96	0.9 1.3	V V
h <sub>FE*</sub>	DC Current Gain	I <sub>C</sub> = 0.1 mA    V <sub>CE</sub> = 10 V I <sub>C</sub> = 10 mA    V <sub>CE</sub> = 10 V I <sub>C</sub> = 150 mA    V <sub>CE</sub> = 10 V I <sub>C</sub> = 10 mA    V <sub>CE</sub> = 10 V T <sub>C</sub> = -55 °C	20 35 40 20	50 80 80 40	120	
h <sub>fe*</sub>	Small Signal Current Gain	I <sub>C</sub> = 1 mA    V <sub>CE</sub> = 5 V    f = 1KHz I <sub>C</sub> = 5 mA    V <sub>CE</sub> = 10 V    f = 1KHz	30 45	70 85	150	
f <sub>T</sub>	Transition Frequency	I <sub>C</sub> = 50 mA    V <sub>CE</sub> = 10 V    f = 20MHz	50	70		MHz
C <sub>CBO</sub>	Collector-Base Capacitance	I <sub>E</sub> = 0    V <sub>CB</sub> = 10 V    f = 1MHz		13	15	pF
C <sub>EBO</sub>	Emitter-Base Capacitance	I <sub>C</sub> = 0    V <sub>EB</sub> = 0.5 V    f = 1MHz		55	85	pF

\* Pulsed: Pulse duration = 300 μs, duty cycle ≤ 1 %

DC Current Gain

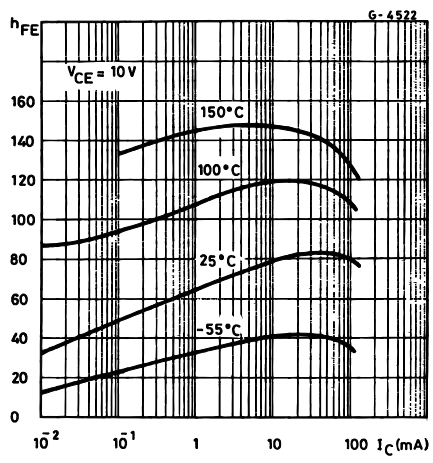

DC Current Gain

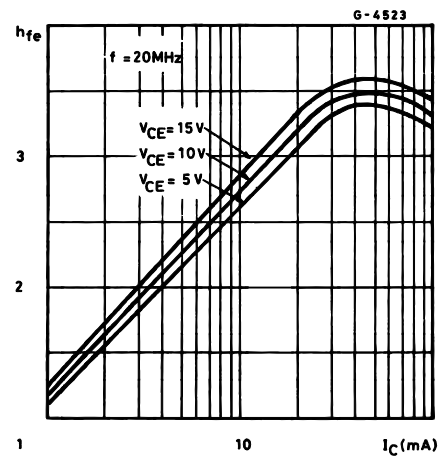

**TO-39 MECHANICAL DATA**

DIM.	mm			inch		
	MIN.	TYP.	MAX.	MIN.	TYP.	MAX.
A	12.7			0.500		
B			0.49			0.019
D			6.6			0.260
E			8.5			0.334
F			9.4			0.370
G	5.08			0.200		
H			1.2			0.047
I			0.9			0.035
L	45° (typ.)					

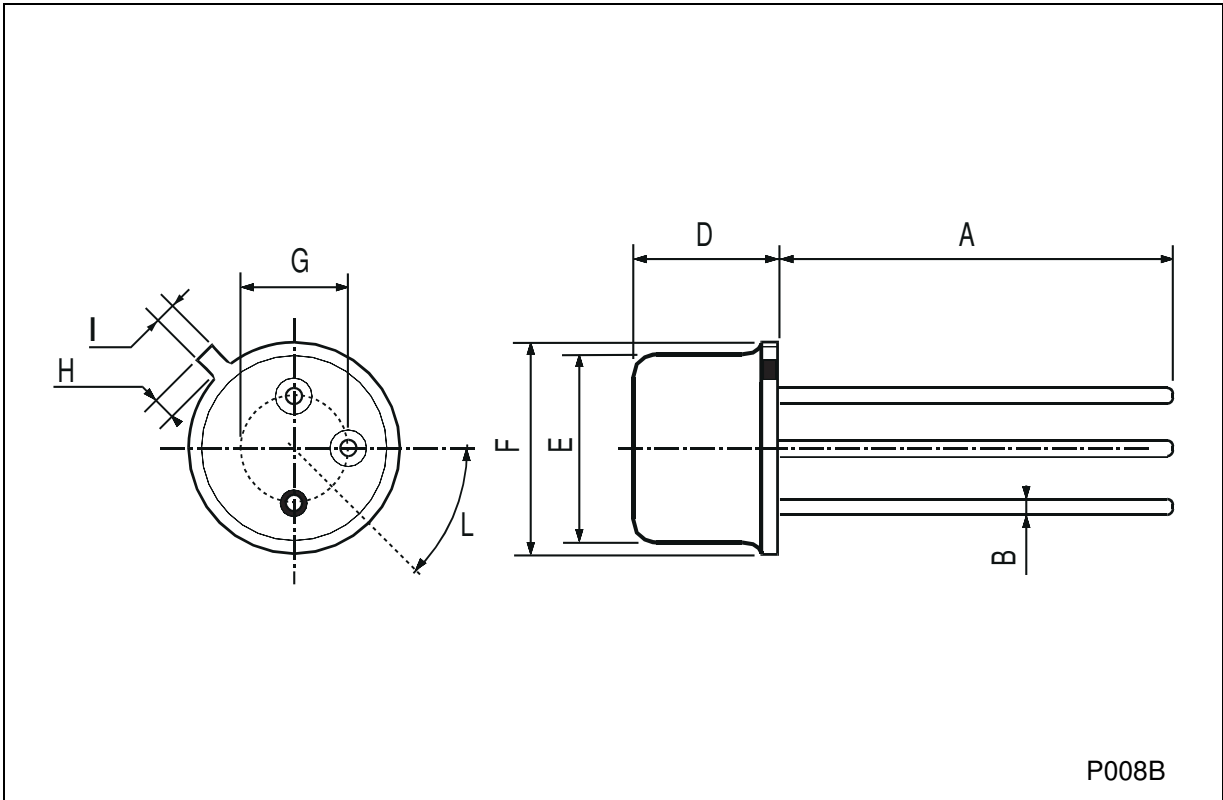

Information furnished is believed to be accurate and reliable. However, STMicroelectronics assumes no responsibility for the consequences of use of such information nor for any infringement of patents or other rights of third parties which may result from its use. No license is granted by implication or otherwise under any patent or patent rights of STMicroelectronics. Specification mentioned in this publication are subject to change without notice. This publication supersedes and replaces all information previously supplied. STMicroelectronics products are not authorized for use as critical components in life support devices or systems without express written approval of STMicroelectronics.

The ST logo is a trademark of STMicroelectronics

© 2002 STMicroelectronics – Printed in Italy – All Rights Reserved

STMicroelectronics GROUP OF COMPANIES

Australia - Brazil - Canada - China - Finland - France - Germany - Hong Kong - India - Israel - Italy - Japan - Malaysia - Malta - Morocco - Singapore - Spain - Sweden - Switzerland - United Kingdom - United States.

<http://www.st.com>