



Chipsmall Limited consists of a professional team with an average of over 10 year of expertise in the distribution of electronic components. Based in Hongkong, we have already established firm and mutual-benefit business relationships with customers from,Europe,America and south Asia,supplying obsolete and hard-to-find components to meet their specific needs.

With the principle of "Quality Parts,Customers Priority,Honest Operation,and Considerate Service",our business mainly focus on the distribution of electronic components. Line cards we deal with include Microchip,ALPS,ROHM,Xilinx,Pulse,ON,Everlight and Freescale. Main products comprise IC,Modules,Potentiometer,IC Socket,Relay,Connector.Our parts cover such applications as commercial,industrial, and automotives areas.

We are looking forward to setting up business relationship with you and hope to provide you with the best service and solution. Let us make a better world for our industry!



Contact us

Tel: +86-755-8981 8866 Fax: +86-755-8427 6832

Email & Skype: info@chipsmall.com Web: www.chipsmall.com

Address: A1208, Overseas Decoration Building, #122 Zhenhua RD., Futian, Shenzhen, China



Key data

1x 574A rms at 690V rms, forced air (fan not implemented)

General information

Stacks for various inverter application.

Please read carefully the complete document and maintain the proper design environment!

Topology	1/2 B2I	
Application / Modulation	Inverter / Sine	
Load type	resistive, inductive	
Cooling	forced air (fan not implemented)	
Implemented sensors	current, temperature	
Semicond. (Unit 1)	none	
DC Link	1.6mF	
Semicond. (Unit 2)	IGBT	4x FF300R17KE4
Driver signals IGBT	electrical CMOS 0 .. 15V	
Standards	EN50178, UL94, prepared for UL508C	
Sales - name	2PS12017E44G35911	
Internal ID	35911	
Mechanical drawing number	35911_MB	
Electrical drawing number	2PS-C4-V	

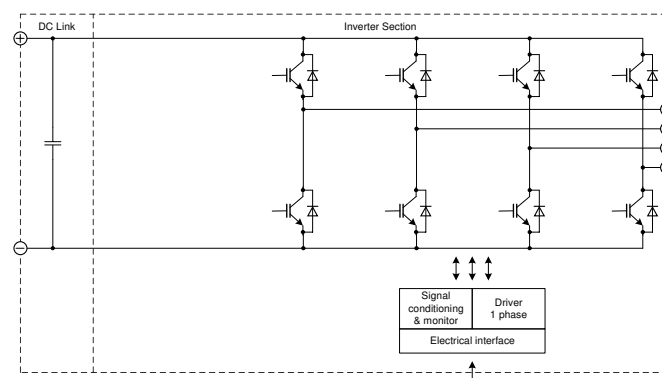
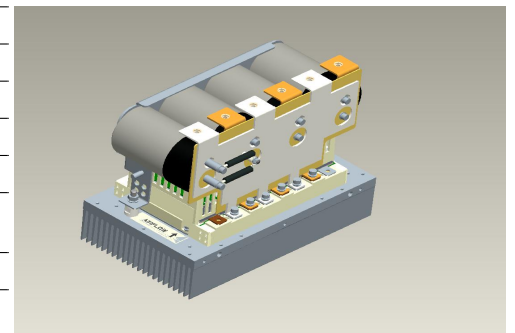

prepared by: OW	date of publication: 2016-02-09
approved by: YZ	revision: 2.0

Technical Information

PrimeSTACK™

2PS12017E44G35911



Preliminary data

Notes

Overtoltage shutdown must be realized by the customer.

Electrical data

DC Link			min	typ	max	units
Voltage		V_{DC}		1100	1200	V

Unit 2 AC			min	typ	max	units
Voltage	depending on controller	V_{Unit2}		690		V_{RMS}
Continuous current	$V_{Unit2} = 690V_{RMS}$, $V_{DC} = 1100V$, $T_{inlet} = 40^{\circ}C$, $T_J \leq 125^{\circ}C$, $f_{Unit2} = 50Hz$, $f_{sw2} = 2000Hz$, $\cos(\phi) = 0,85$	I_{Unit2}			574	A_{RMS}
Continuous current overload cap.	$T_{inlet} = 40^{\circ}C$, for overload capability 150% for 60s			418		A_{RMS}
Short time current	$T_{inlet} = 40^{\circ}C$, 10s, every 180s, initial load = $510A_{RMS}$	I_{Unit2}			638	A_{RMS}
DC current	no rotating field, $T_{inlet} = 40^{\circ}C$	$I_{Unit2 DC}$			280,0	A_{av}
Overcurrent shutdown	within 15 μ s			2500		A_{peak}
Switching frequency		f_{sw2}			7000	Hz
Power losses	$V_{Unit2} = 690V$, $V_{DC} = 1100V$, $T_{inlet} = 40^{\circ}C$, $T_J \leq 125^{\circ}C$, $f_{Unit2} = 50Hz$, $f_{sw2} = 2000Hz$, $\cos(\phi) = 0,85$, $I_{Unit2} = 574A_{RMS}$	P_{loss2}		2160		W
Power factor		$\cos(\phi)_{Unit2}$	-1,00		1,00	

General data			min	typ	max	units
Power losses (PCB)		$P_{loss aux}$			40	W
EMC test	according to IEC61800-3 at named interfaces	power	V_{Burst}	2		kV
		control	V_{Burst}	1		kV
		aux (24V)	V_{Surge}	1		kV
Insulation management is designed for		V_{Line}		690		V_{RMS}
Insulation test voltage	according to EN50178, $f = 50Hz$, $t = 60s$	V_{isol}		2,5		kV_{RMS}

Controller interface data			min	typ	max	units
Auxiliary voltage		V_{aux}	13	24	30	V_{av}
Auxiliary power requirement	$V_{aux} = 24V_{av}$	P_{aux}		40		W
Driver and interface board	see separate technical information			DR240		
Driver core				EiceDRIVER 2ED300C17-S		
Digital input level	resistor to GND 10,0k Ω , capacitor to GND 1nF	V_{in}	0,0		15,0	V
Digital output level	open collector, low = ok, max 15mA	V_{out}	0,0		30,0	V
Analog current outputs Unit 2	load max 1mA; at 574A	$V_{ana out}$	3,10	3,16	3,22	V
Analog temperature output	load max 1mA; at $T_{NTC} = 76^{\circ}C$ correspond to $T_J = 125^{\circ}C$	$V_{T out}$	8,69	8,87	9,05	V
Overtemperature shutdown	at $T_{NTC} = 81^{\circ}C$ correspond to $T_J = 136^{\circ}C$	$V_{T out OT}$		10		V

prepared by: OW	date of publication: 2016-02-09
approved by: YZ	revision: 2.0

Technical Information

PrimeSTACK™

2PS12017E44G35911



Preliminary data

Heat sink air cooled / Thermal data

			min	typ	max	units
Airflow	$T_{\text{Air}} = 20^{\circ}\text{C}$, $P_{\text{air}} = 1013\text{hPa}$, dry- and dust free, measured on side of heat sink. according to DIN 41882	$\Delta V / \Delta t_{\text{Air}}$	500			m^3/h
Air pressure drop		Δp_{Air}		190		Pa
Cooling air inlet temperature	heat sink temperature $> -25^{\circ}\text{C}$	T_{inlet}	-40		40	$^{\circ}\text{C}$

prepared by: OW	date of publication: 2016-02-09
approved by: YZ	revision: 2.0

Technical Information

PrimeSTACK™

2PS12017E44G35911



Preliminary data

IGBT data unit 2

Type			min	typ	max	units
Type	assumed					
collector-emitter saturation voltage	$I_c = 300A; V_{ge} = 15V; T_{vj} = 150^\circ C$	$V_{CE\ sat}$		2,45		V
parameter for linear model	$T_{vj} = 25^\circ C$	V_{ce1}		1,176		V
parameter for linear model	$T_{vj} = 25^\circ C$	r_{ce1}		2,582		mΩ
parameter for linear model	$T_{vj} = 150^\circ C$	V_{ce2}		1,082		V
parameter for linear model	$T_{vj} = 150^\circ C$	r_{ce2}		4,56		mΩ
turn-on / turn-off energy loss per pulse	$T_{vj} = 25^\circ C$	E_1		63 / 55		mJ
turn-on / turn-off energy loss per pulse	$T_{vj} = 150^\circ C$	E_2		93 / 100		mJ
thermal resistance, junction to case	per IGBT	R_{thjc}		0,083		K/W
thermal resistance, case to heatsink	per IGBT	R_{thch}		0,033		K/W

Diode data unit 2

Type			min	typ	max	units
Type	assumed					
forward voltage	$I_F = 300A; V_{ge} = 0V; T_{vj} = 150^\circ C$	V_F		1,95		V
parameter for linear model	$T_{vj} = 25^\circ C$	V_{F1}		1,158		V
parameter for linear model	$T_{vj} = 25^\circ C$	r_{F1}		2,139		mΩ
parameter for linear model	$T_{vj} = 150^\circ C$	V_{F2}		1,062		V
parameter for linear model	$T_{vj} = 150^\circ C$	r_{F2}		2,959		mΩ
reverse recovery energy	$T_{vj} = 25^\circ C$	E_{rec1}		28		mJ
reverse recovery energy	$T_{vj} = 150^\circ C$	E_{rec2}		68		mJ
thermal resistance, junction to case	per Diode	R_{thjc}		0,13		K/W
thermal resistance, case to heatsink	per Diode	R_{thch}		0,051		K/W

Environmental conditions

			min	typ	max	units
Storage temperature		T_{stor}	-40		85	°C
Ambient temperature		T_{amb}	-25		55	°C
Operating temperature	see chapter Heat sink air cooled / Thermal data					
Cooling air velocity (PCB)		$V_{Air\ PCB}$	2,0			m/s
Air pressure	standard atmosphere	p_{Air}	900		1100	hPa
Humidity	no condensation	Rel. F	5		85	%
Installation height			0		1000	m
Vibration	according to IEC60721				5	m/s ²
Shock	according to IEC60721				40	m/s ²
Protection degree			IP00			
Pollution degree			2			
Torque at DC Terminals		M_{DC}	6,0		10,0	Nm
Torque at AC Terminals		M_{AC}	16,0		20,0	Nm
Dimensions	width × depth × height		216	360	288	mm
Weight with heat sink	approximation			18,0		kg

prepared by: OW	date of publication: 2016-02-09
approved by: YZ	revision: 2.0

Preliminary data

fo - derating curve IGBT (motor), Diode (generator)
 cos(phi) = ± 0,85
 T_{cool medium} = 40°C

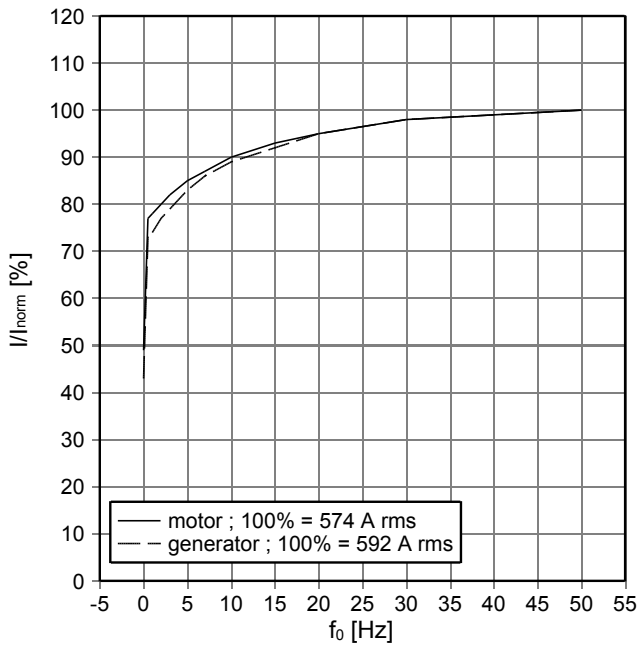

fsw - derating curve IGBT (motor), Diode (generator)
 cos(phi) = ± 0,85
 T_{cool medium} = 40°C

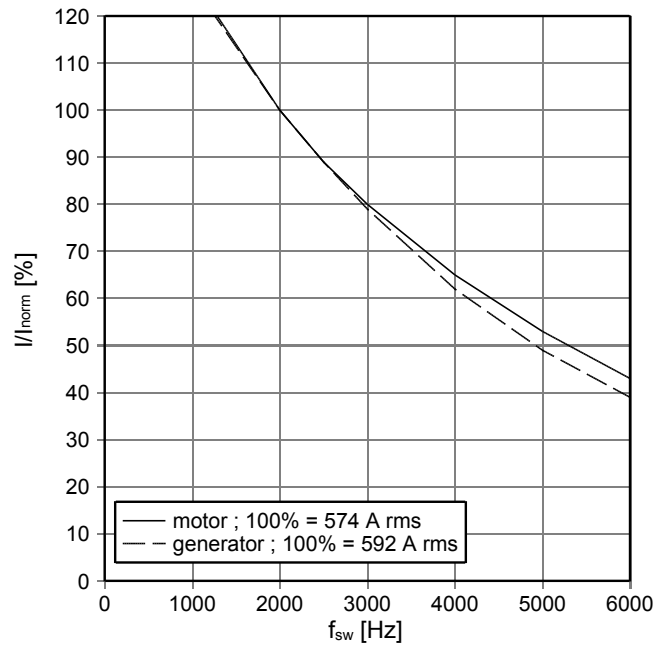

Transient thermal impedance per module
 T_{cool medium} = 40°C

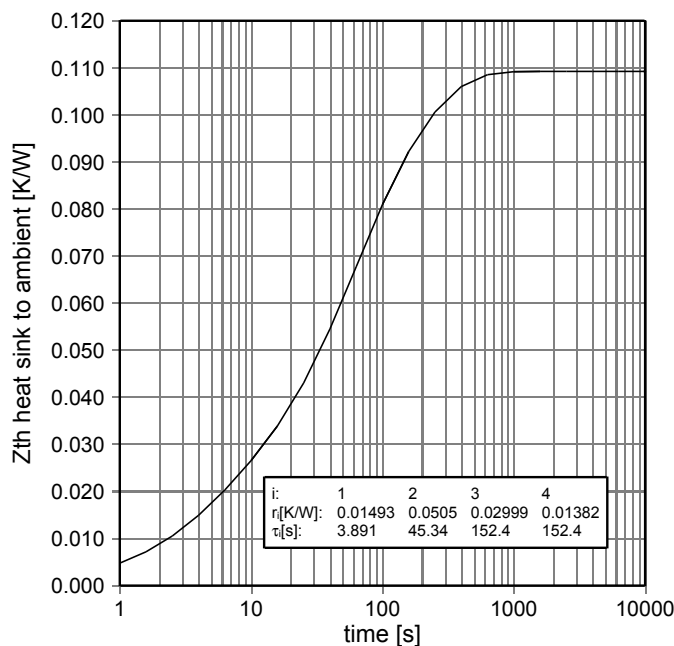

prepared by: OW	date of publication: 2016-02-09
approved by: YZ	revision: 2.0

Mechanical drawing

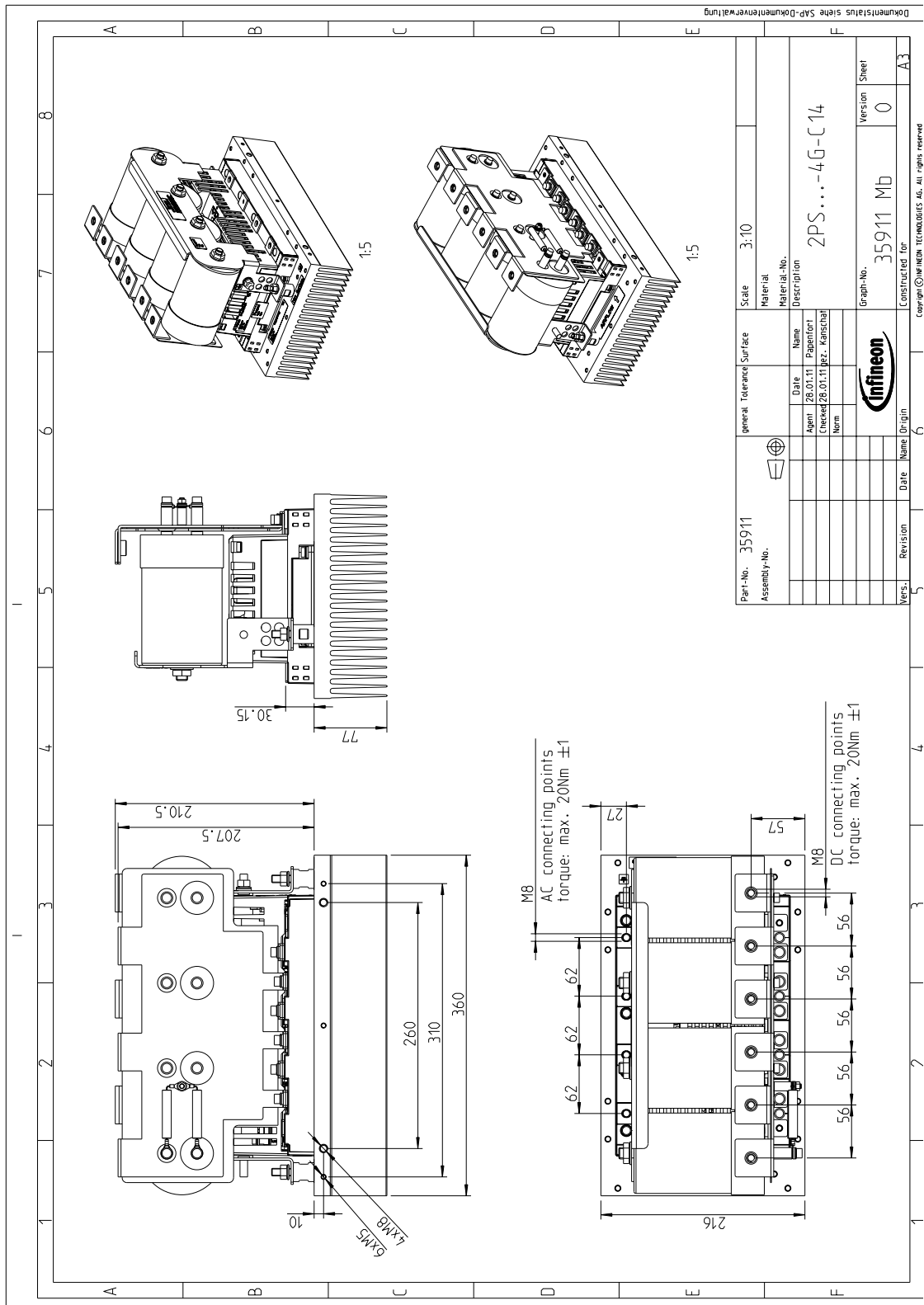

Documentstatus siehe SAP-Dokumentverwaltung

Part-No.	35911	Scale	3:10
Assembly-No.		Material	
		Description	2PS...-4G-C14
		Graph-No.	35911 Mb
		Version	0
		Sheet	
		Constructed for	A3
		Copyright	© INFINEON TECHNOLOGIES AG. All rights reserved.

prepared by: OW	date of publication: 2016-02-09
approved by: YZ	revision: 2.0

Circuit diagram

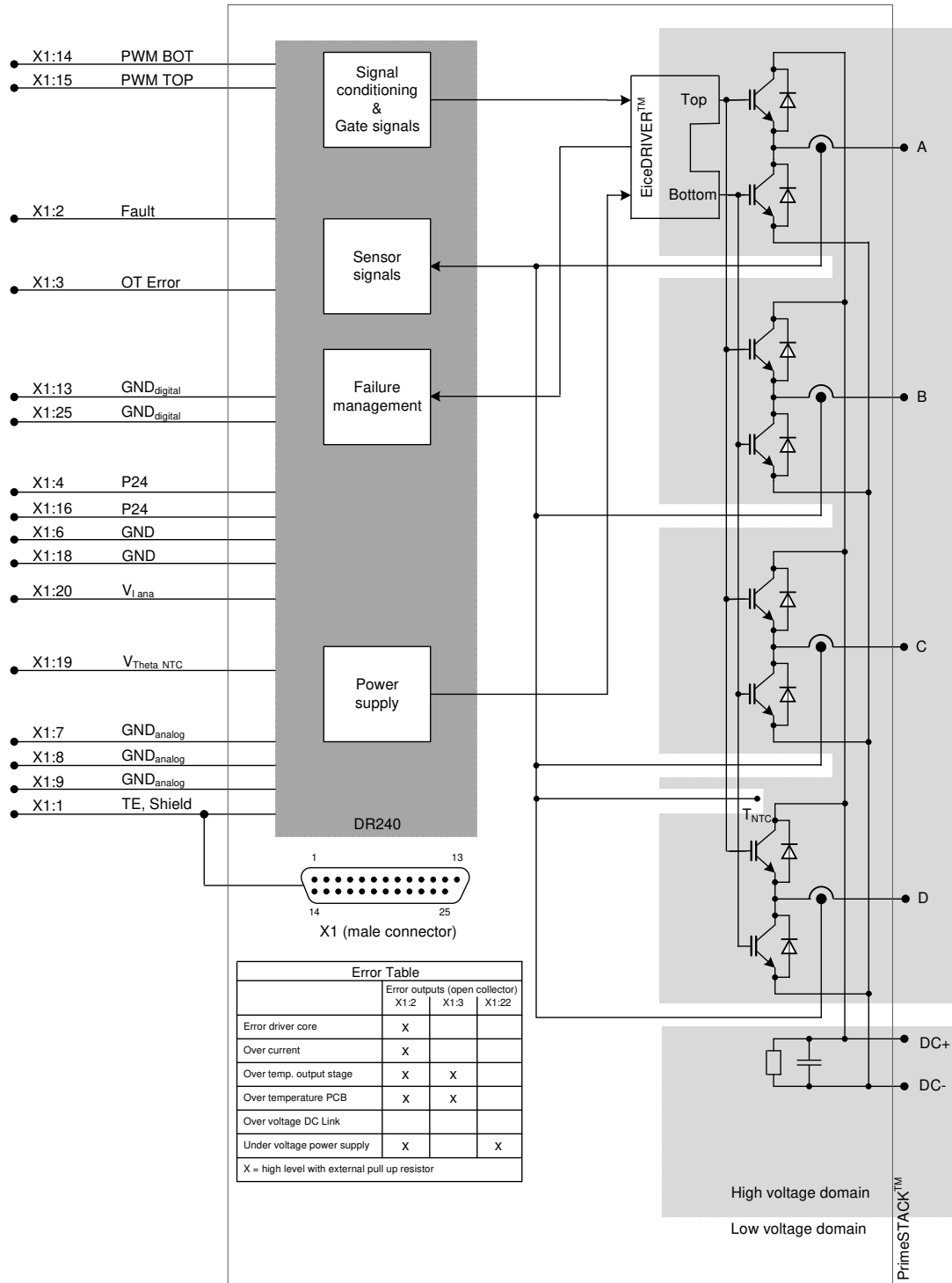



Preliminary data

Terms & Conditions of usage

The data contained in this product data sheet is exclusively intended for technically trained staff. You and your technical departments will have to evaluate the suitability of the product for the intended application and the completeness of the product data with respect to such application.

This product data sheet is describing the characteristics of this product for which a warranty is granted. Any such warranty is granted exclusively pursuant to the terms and conditions of the supply agreement. There will be no guarantee of any kind for the product and its characteristics.

Should you require product information in excess of the data given in this product data sheet or which concerns the specific application of our product, please contact the sales office, which is responsible for you (see www.infineon.com, sales&contact). For those that are specifically interested we may provide application notes.

Due to technical requirements our product may contain dangerous substances. For information on the types in question please contact the sales office, which is responsible for you.

Should you intend to use the Product in aviation applications, in health or live endangering or life support applications, please notify. Please note, that for any such applications we urgently recommend

- to perform joint Risk and Quality Assessments;
- the conclusion of Quality Agreements;
- to establish joint measures of an ongoing product survey, and that we may make delivery depended on the realization of any such measures.

If and to the extent necessary, please forward equivalent notices to your customers.

Changes of this product data sheet are reserved.

Safety Instructions

Prior to installation and operation, all safety notices and warnings and all warning signs attached to the equipment have to be carefully read. Make sure that all warning signs remain in a legible condition and that missing or damaged signs are replaced. To installation and operation, all safety notices and warnings and all warning signs attached to the equipment have to be carefully read. Make sure that all warning signs remain in a legible condition and that missing or damaged signs are replaced.

prepared by: OW	date of publication: 2016-02-09
approved by: YZ	revision: 2.0