



Chipsmall Limited consists of a professional team with an average of over 10 year of expertise in the distribution of electronic components. Based in Hongkong, we have already established firm and mutual-benefit business relationships with customers from,Europe,America and south Asia,supplying obsolete and hard-to-find components to meet their specific needs.

With the principle of "Quality Parts,Customers Priority,Honest Operation,and Considerate Service",our business mainly focus on the distribution of electronic components. Line cards we deal with include Microchip,ALPS,ROHM,Xilinx,Pulse,ON,Everlight and Freescale. Main products comprise IC,Modules,Potentiometer,IC Socket,Relay,Connector.Our parts cover such applications as commercial,industrial, and automotives areas.

We are looking forward to setting up business relationship with you and hope to provide you with the best service and solution. Let us make a better world for our industry!



Contact us

Tel: +86-755-8981 8866 Fax: +86-755-8427 6832

Email & Skype: info@chipsmall.com Web: www.chipsmall.com

Address: A1208, Overseas Decoration Building, #122 Zhenhua RD., Futian, Shenzhen, China



Medium Power Transistor (32V, 1A)

2SD1664 / 2SD1858

●Features

- 1) Low $V_{CE(sat)}$, $V_{CE(sat)} = 0.15V$ (typical).
($I_c/I_b = 500mA/50mA$)
- 2) Complements the
2SB1132 / 2SB1237.

●Structure

Epitaxial planar type
NPN silicon transistor

●External dimensions (Units: mm)

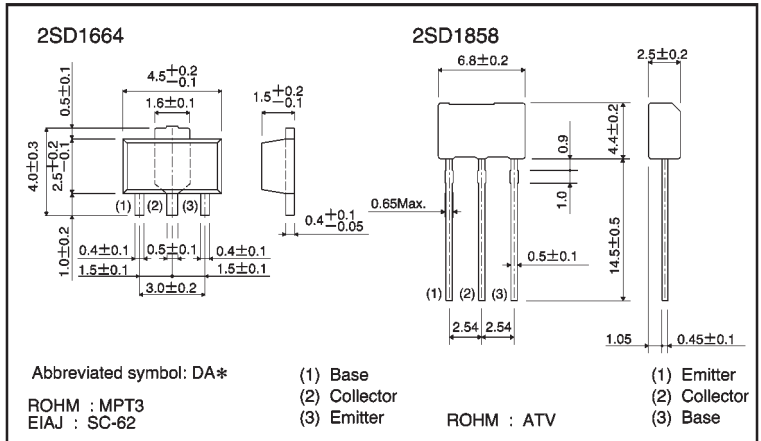

●Absolute maximum ratings ($T_a = 25^\circ C$)

| Parameter | Symbol | Limits | Unit |
|-----------------------------|-----------|----------|--------------|
| Collector-base voltage | V_{CBO} | 40 | V |
| Collector-emitter voltage | V_{CEO} | 32 | V |
| Emitter-base voltage | V_{EBO} | 5 | V |
| Collector current | I_c | 1 | A (DC) |
| | | 2 | A (Pulse) *1 |
| Collector power dissipation | 2SD1664 | 0.5 | W *2 |
| | | 2 | |
| | 2SD1858 | 1 | *3 |
| Junction temperature | T_j | 150 | $^\circ C$ |
| Storage temperature | T_{stg} | -55~+150 | $^\circ C$ |

*1 $P_w=20ms$, $duty=1/2$

*2 When mounted on a 40×40×0.7 mm ceramic board.

*3 When it is mounted on the copper clad PCB (1.7mm thick) with land size for collector 1 square CM or larger.

●Electrical characteristics (Ta = 25°C)

| Parameter | Symbol | Min. | Typ. | Max. | Unit | Conditions |
|--------------------------------------|----------------------|------|------|------|------|--|
| Collector-base breakdown voltage | BV _{CBO} | 40 | — | — | V | I _c =50 μA |
| Collector-emitter breakdown voltage | BV _{CEO} | 32 | — | — | V | I _c =1mA |
| Emitter-base breakdown voltage | BV _{EBO} | 5 | — | — | V | I _E =50 μA |
| Collector cutoff current | I _{cBO} | — | — | 0.5 | μA | V _{CB} =20V |
| Emitter cutoff current | I _{EBO} | — | — | 0.5 | μA | V _{EB} =4V |
| DC current transfer ratio | h _{FE} | 82 | — | 390 | — | V _{CE} =3V, I _c =100mA |
| Collector-emitter saturation voltage | V _{CE(sat)} | — | 0.15 | 0.4 | V | I _c /I _B =500mA/50mA |
| Transition frequency | f _r | — | 150 | — | MHz | V _{CE} =5V, I _E =-50mA, f=100MHz |
| Output capacitance | C _{ob} | — | 15 | — | pF | V _{CB} =10V, I _E =0A, f=1MHz |

●Packaging specifications and h_{FE}

| Type | h _{FE} | Package | Taping | |
|---------|-----------------|------------------------------|--------|------|
| | | Code | T100 | TV2 |
| | | Basic ordering unit (pieces) | 1000 | 2500 |
| 2SD1664 | PQR | ○ | — | — |
| 2SD1858 | PQR | — | ○ | — |

h_{FE} values are classified as follows :

| Item | P | Q | R |
|-----------------|--------|---------|---------|
| h _{FE} | 82~180 | 120~270 | 180~390 |

●Electrical characteristic curves

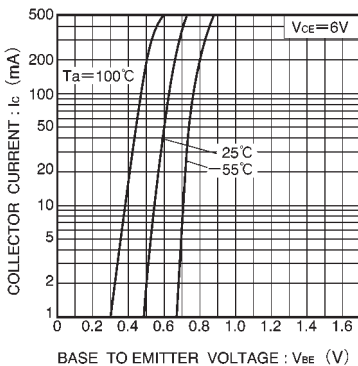

Fig.1 Grounded emitter propagation characteristics

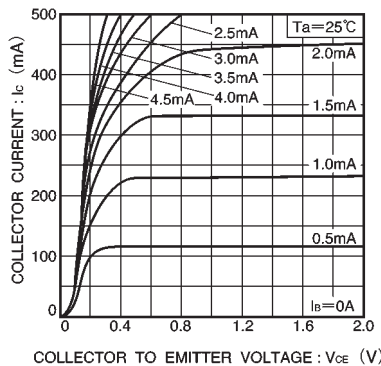

Fig.2 Grounded emitter output characteristics

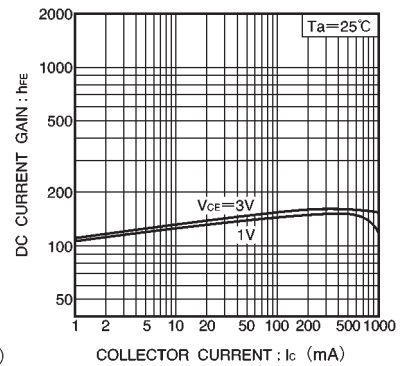

Fig.3 DC current gain vs. collector current (I)

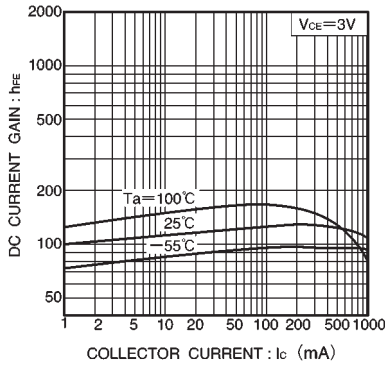

Fig.4 DC current gain vs. collector current (II)

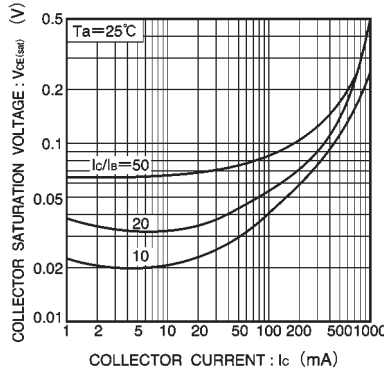

Fig.5 Collector-emitter saturation voltage vs. collector current (I)

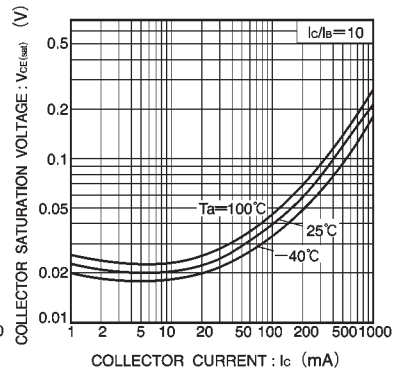

Fig.6 Collector-emitter saturation voltage vs. collector current (II)

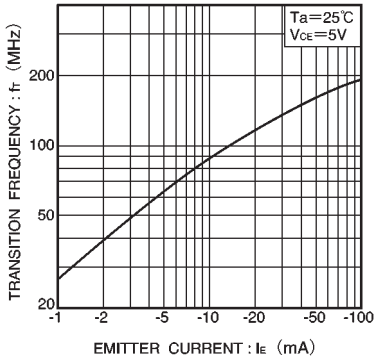

Fig.7 Gain bandwidth product vs. emitter current

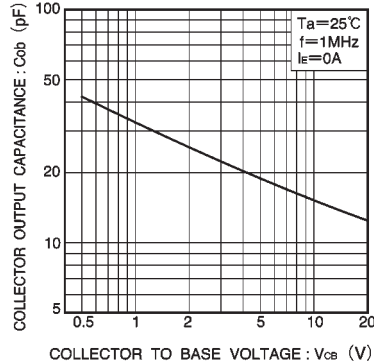

Fig.8 Collector output capacitance vs. collector-base voltage

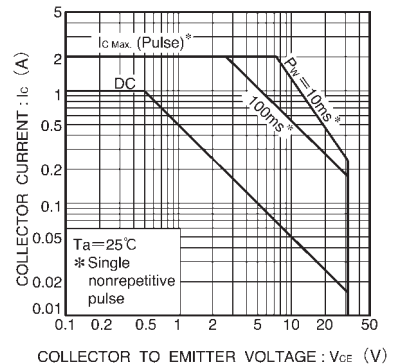

Fig.9 Safe operating area (2SD1664)

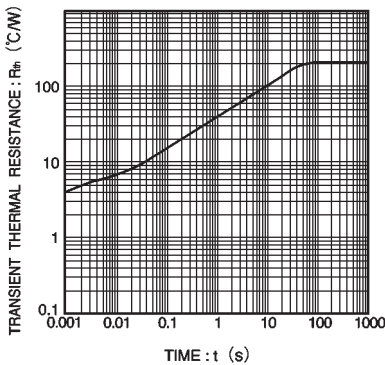

Fig.10 Transient thermal resistance (2SD1664)

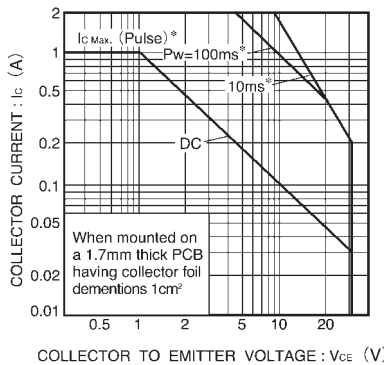

Fig.11 Safe operating area (2SD1858)

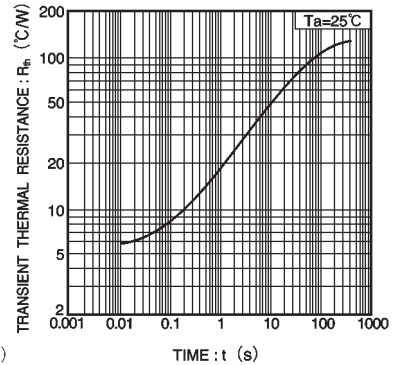

Fig.12 Transient thermal resistance (2SD1858)