



Chipsmall Limited consists of a professional team with an average of over 10 year of expertise in the distribution of electronic components. Based in Hongkong, we have already established firm and mutual-benefit business relationships with customers from,Europe,America and south Asia,supplying obsolete and hard-to-find components to meet their specific needs.

With the principle of "Quality Parts,Customers Priority,Honest Operation,and Considerate Service",our business mainly focus on the distribution of electronic components. Line cards we deal with include Microchip,ALPS,ROHM,Xilinx,Pulse,ON,Everlight and Freescale. Main products comprise IC,Modules,Potentiometer,IC Socket,Relay,Connector.Our parts cover such applications as commercial,industrial, and automotives areas.

We are looking forward to setting up business relationship with you and hope to provide you with the best service and solution. Let us make a better world for our industry!



## Contact us

Tel: +86-755-8981 8866 Fax: +86-755-8427 6832

Email & Skype: info@chipsmall.com Web: www.chipsmall.com

Address: A1208, Overseas Decoration Building, #122 Zhenhua RD., Futian, Shenzhen, China



## High gain Low Voltage PNP power transistor

### Features

- Very low Collector to Emitter saturation voltage
- D.C. Current gain,  $h_{FE} > 100$
- 1.5 A continuous collector current

### Applications

- Power management in portable equipment
- Switching regulator in battery charger applications

### Description

The device is a PNP transistor manufactured using new "PB-HDC" (Power Bipolar High Density Current) technology. The resulting transistor shows exceptional high gain performances coupled with very low saturation voltage.

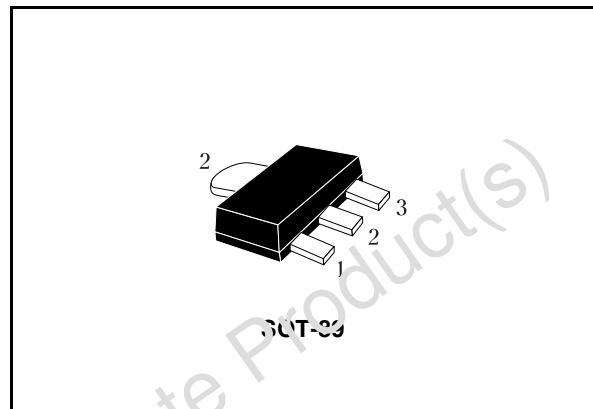

Figure 1. Internal schematic diagram

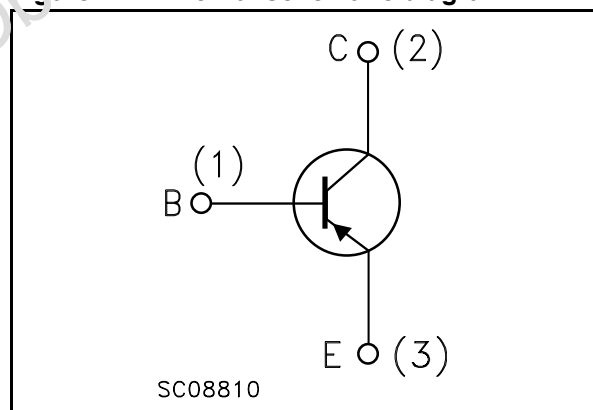

Table 1. Device summary

Order code	Marking	Package	Packaging
2STF2220	2220	SOT-89	Tape & reel

---

## Contents

<b>1</b>	<b>Electrical ratings</b> .....	<b>3</b>
<b>2</b>	<b>Electrical characteristics</b> .....	<b>4</b>
2.1	Electrical characteristics (curves) .....	5
2.2	Test circuits .....	7
<b>3</b>	<b>Package mechanical data</b> .....	<b>8</b>
<b>4</b>	<b>Revision history</b> .....	<b>10</b>

Obsolete Product(s) - Obsolete Product(s)

# 1 Electrical ratings

**Table 2. Absolute maximum rating**

Symbol	Parameter	Value	Unit
$V_{CBO}$	Collector-base voltage ( $I_E = 0$ )	-20	V
$V_{CEO}$	Collector-emitter voltage ( $I_B = 0$ )	-20	V
$V_{EBO}$	Emitter-base voltage ( $I_C = 0$ )	-5	V
$I_C$	Collector current	-1.5	A
$I_{CM}$	Collector peak current ( $t_P < 5\text{ms}$ )	-3	A
$I_B$	Base current	-0.1	A
$I_{BM}$	Base peak current ( $t_P < 5\text{ms}$ )	-0.2	A
$P_{tot}$	Total dissipation at $T_{amb} = 25^\circ\text{C}$	1.4	W
$T_{stg}$	Storage temperature	-65 to 150	$^\circ\text{C}$
$T_J$	Max. operating junction temperature	150	$^\circ\text{C}$

**Table 3. Thermal data**

Symbol	Parameter	Value	Unit
$R_{thj-amb}^{(1)}$	Thermal resistance junction-amb max	89	$^\circ\text{C}/\text{W}$

(1) Device mounted on PCB area of  $1\text{cm}^2$

## 2 Electrical characteristics

( $T_{\text{case}} = 25^{\circ}\text{C}$  unless otherwise specified)

**Table 4. Electrical characteristics**

Symbol	Parameter	Test Conditions	Min.	Typ.	Max.	Unit
$I_{\text{CBO}}$	Collector cut-off current ( $I_{\text{E}} = 0$ )	$V_{\text{CB}} = -20\text{V}$			-0.1	$\mu\text{A}$
$I_{\text{EBO}}$	Emitter cut-off current ( $I_{\text{C}} = 0$ )	$V_{\text{EB}} = -5\text{V}$			-0.1	$\mu\text{A}$
$V_{(\text{BR})\text{CEO}}^{(2)}$	Collector-emitter breakdown voltage ( $I_{\text{B}} = 0$ )	$I_{\text{C}} = -10\text{mA}$	-20			V
$V_{(\text{BR})\text{EBO}}$	Emitter-base breakdown voltage ( $I_{\text{C}} = 0$ )	$I_{\text{E}} = -100\mu\text{A}$	-5			V
$V_{\text{CE}(\text{sat})}^{(2)}$	Collector-emitter saturation voltage	$I_{\text{C}} = -0.5\text{A}$ $I_{\text{B}} = -50\text{mA}$			-0.25	V
		$I_{\text{C}} = -1.5\text{A}$ $I_{\text{B}} = -150\text{mA}$			-0.45	V
$V_{\text{BE}(\text{sat})}^{(2)}$	Base-emitter saturation voltage	$I_{\text{C}} = -0.5\text{A}$ $I_{\text{B}} = -50\text{mA}$			-1	V
		$I_{\text{C}} = -1.5\text{A}$ $I_{\text{B}} = -150\text{mA}$			-1.1	V
$V_{\text{BE}(\text{on})}^{(2)}$	Base-emitter on voltage	$I_{\text{C}} = -1\text{A}$ $V_{\text{CE}} = -2\text{V}$			-1	V
$h_{\text{FE}}^{(2)}$	DC current gain	$I_{\text{C}} = -100\text{mA}$ $V_{\text{CE}} = -2\text{V}$	200		600	
		$I_{\text{C}} = -500\text{mA}$ $V_{\text{CE}} = -2\text{V}$	170			
		$I_{\text{C}} = -1.5\text{A}$ $V_{\text{CE}} = -2\text{V}$	120			
		$I_{\text{C}} = -3\text{A}$ $V_{\text{CE}} = -2\text{V}$	75			
$C_{\text{CBQ}}$	Collector-base capacitance	$I_{\text{E}} = 0$ $V_{\text{CB}} = -10\text{V}$ $f = 1\text{MHz}$		30		pF
$t_{\text{on}}$ $t_{\text{off}}$	Resistive load Turn-on time	$I_{\text{C}} = -1.5\text{A}$ $V_{\text{CC}} = -10\text{V}$		60		ns
	Turn-off time	$I_{\text{B}1} = -I_{\text{B}2} = -150\text{mA}$		250		ns

Note (2) Pulsed duration = 300  $\mu\text{s}$ , duty cycle  $\leq 1.5\%$

## 2.1 Electrical characteristics (curves)

Figure 2. Output characteristics

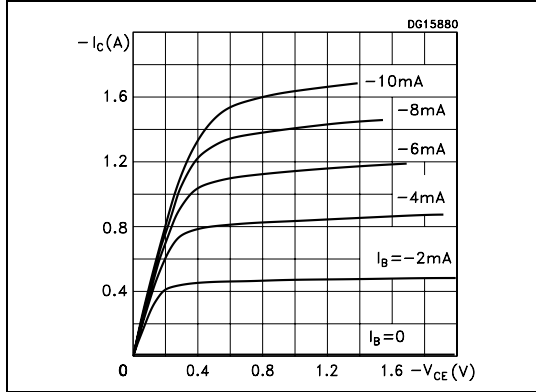

Figure 3. Derating curve

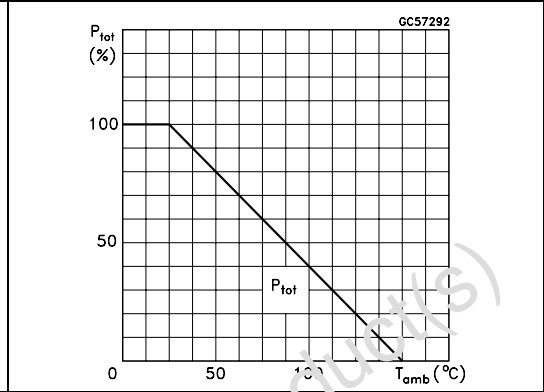

Figure 4. DC current gain

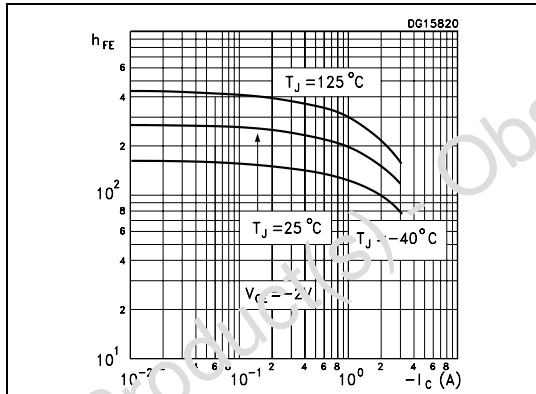

Figure 5. DC current gain

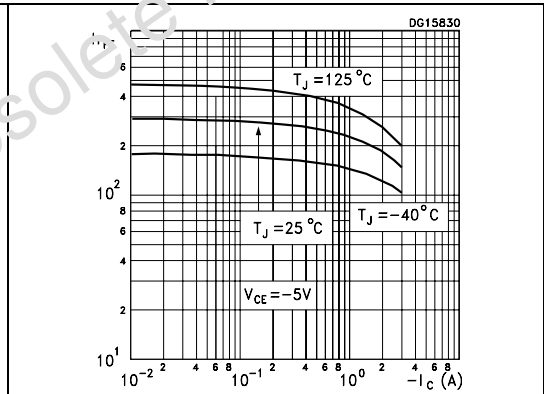

Figure 6. Collector-emitter saturation voltage

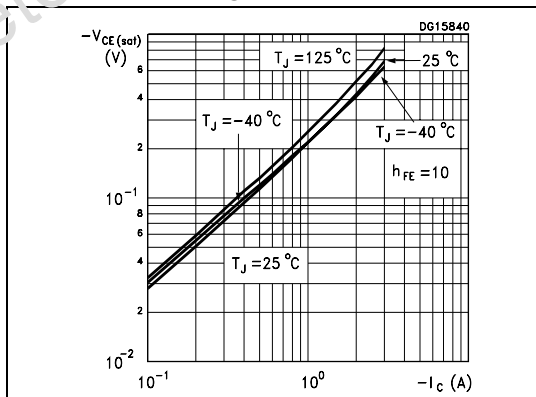

Figure 7. Base-emitter saturation voltage

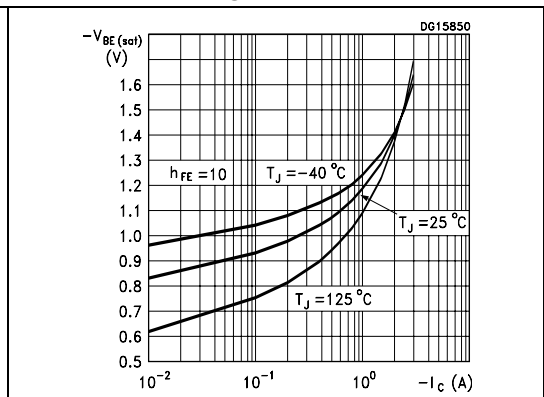

Figure 8. Base-emitter on voltage

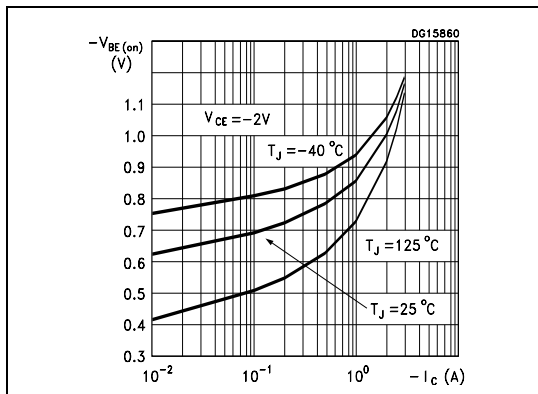

Figure 9. Capacitance curves

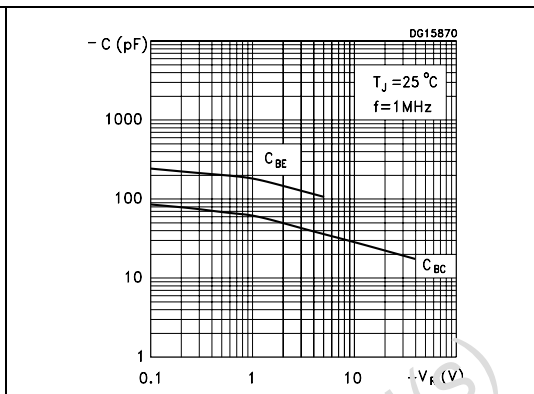

Figure 10. Switching time resistive load

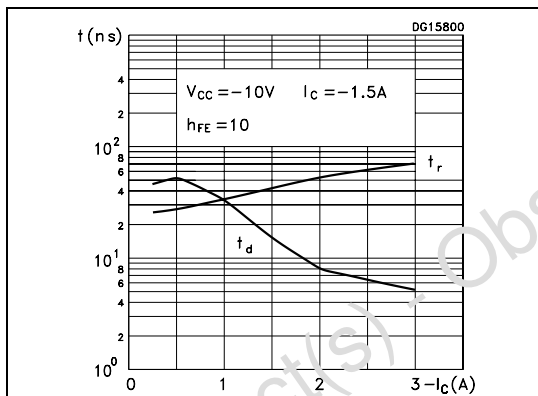
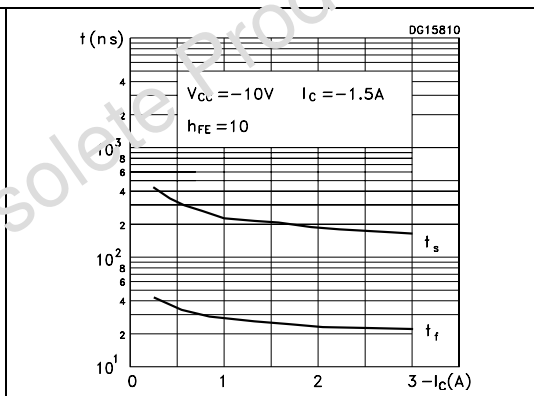
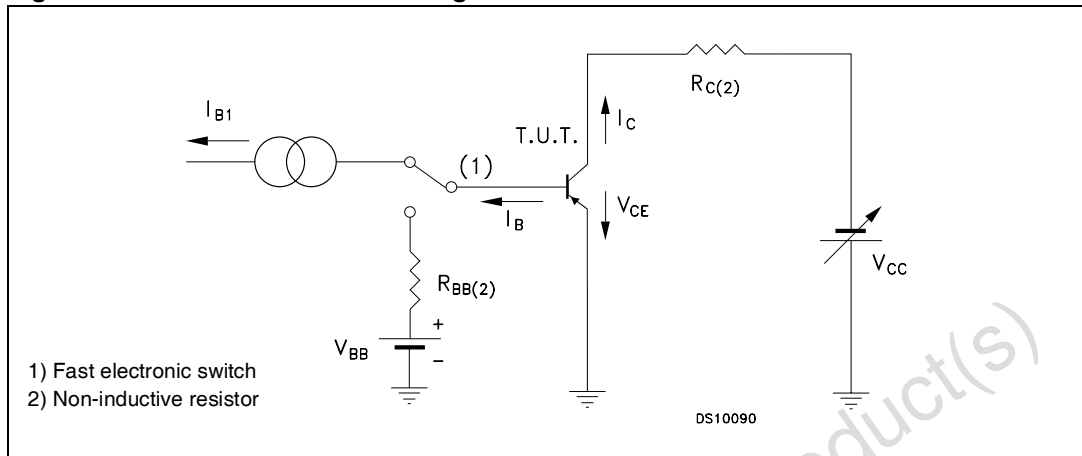

Figure 11. Switching time resistive load



## 2.2 Test circuits

Figure 12. Resistive load switching test circuit



### 3 Package mechanical data

In order to meet environmental requirements, ST offers these devices in ECOPACK® packages. These packages have a Lead-free second level interconnect. The category of second level interconnect is marked on the package and on the inner box label, in compliance with JEDEC Standard JESD97. The maximum ratings related to soldering conditions are also marked on the inner box label. ECOPACK is an ST trademark. ECOPACK specifications are available at: [www.st.com](http://www.st.com)

Obsolete Product(s) - Obsolete Product(s)

## SOT-89 MECHANICAL DATA

DIM.	mm			mils		
	MIN.	TYP.	MAX.	MIN.	TYP.	MAX.
A	1.4		1.6	55.1		63.0
B	0.44		0.56	17.3		22.0
B1	0.36		0.48	14.2		13.9
C	0.35		0.44	13.8		17.3
C1	0.35		0.44	13.8		17.3
D	4.4		4.6	173.2		181.1
D1	1.62		1.83	63.8		72.0
E	2.29		2.6	90.2		102.4
e	1.42		1.57	55.9		61.8
e1	2.92		3.07	115.0		120.9
H	3.94		4.25	155.1		167.3
L	0.89		1.2	35.0		47.2

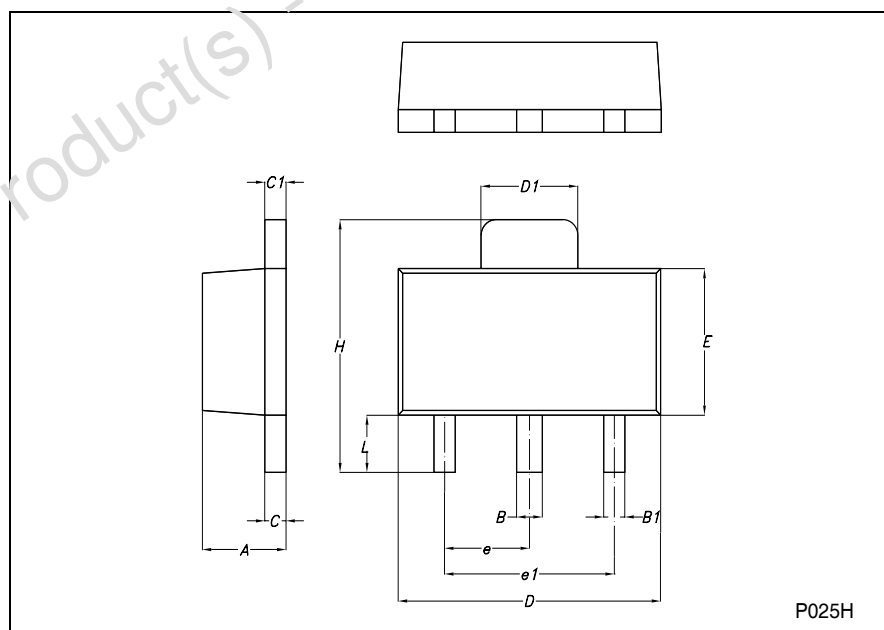

## 4 Revision history

**Table 5. Document revision history**

Date	Revision	Changes
19-Jun-2006	1	Initial release.
27-Sep-2006	2	New maturity code.
18-Sep-2007	3	Added <a href="#">Figure 3</a> .

Obsolete Product(s) - Obsolete Product(s)

**Please Read Carefully:**

Information in this document is provided solely in connection with ST products. STMicroelectronics NV and its subsidiaries ("ST") reserve the right to make changes, corrections, modifications or improvements, to this document, and the products and services described herein at any time, without notice.

All ST products are sold pursuant to ST's terms and conditions of sale.

Purchasers are solely responsible for the choice, selection and use of the ST products and services described herein, and ST assumes no liability whatsoever relating to the choice, selection or use of the ST products and services described herein.

No license, express or implied, by estoppel or otherwise, to any intellectual property rights is granted under this document. If any part of this document refers to any third party products or services it shall not be deemed a license grant by ST for the use of such third party products or services, or any intellectual property contained therein or considered as a warranty covering the use in any manner whatsoever of such third party products or services or any intellectual property contained therein.

**UNLESS OTHERWISE SET FORTH IN ST'S TERMS AND CONDITIONS OF SALE ST DISCLAIMS ANY EXPRESS OR IMPLIED WARRANTY WITH RESPECT TO THE USE AND/OR SALE OF ST PRODUCTS INCLUDING WITHOUT LIMITATION IMPLIED WARRANTIES OF MERCHANTABILITY, FITNESS FOR A PARTICULAR PURPOSE (AND THEIR EQUIVALENTS UNDER THE LAWS OF ANY JURISDICTION), OR INFRINGEMENT OF ANY PATENT, COPYRIGHT OR OTHER INTELLECTUAL PROPERTY RIGHT.**

**UNLESS EXPRESSLY APPROVED IN WRITING BY AN AUTHORIZED ST REPRESENTATIVE, ST PRODUCTS ARE NOT RECOMMENDED, AUTHORIZED OR WARRANTED FOR USE IN MILITARY, AIR CRAFT, SPACE, LIFE SAVING, OR LIFE SUSTAINING APPLICATIONS, NOR IN PRODUCTS OR SYSTEMS WHERE FAILURE OR MALFUNCTION MAY RESULT IN PERSONAL INJURY, DEATH, OR SEVERE PROPERTY OR ENVIRONMENTAL DAMAGE. ST PRODUCTS WHICH ARE NOT SPECIFIED AS "AUTOMOTIVE GRADE" MAY ONLY BE USED IN AUTOMOTIVE APPLICATIONS AT USER'S OWN RISK.**

Resale of ST products with provisions different from the statements and/or technical features set forth in this document shall immediately void any warranty granted by ST for the ST product or service described herein and shall not create or extend in any manner whatsoever, any liability of ST.

ST and the ST logo are trademarks or registered trademarks of ST in various countries.

Information in this document supersedes and replaces all information previously supplied.

The ST logo is a registered trademark of STMicroelectronics. All other names are the property of their respective owners.

© 2007 STMicroelectronics - All rights reserved

STMicroelectronics group of companies

Australia - Belgium - Brazil - Canada - China - Czech Republic - Finland - France - Germany - Hong Kong - India - Israel - Italy - Japan - Malaysia - Malta - Morocco - Singapore - Spain - Sweden - Switzerland - United Kingdom - United States of America

[www.st.com](http://www.st.com)