



Chipsmall Limited consists of a professional team with an average of over 10 year of expertise in the distribution of electronic components. Based in Hongkong, we have already established firm and mutual-benefit business relationships with customers from,Europe,America and south Asia,supplying obsolete and hard-to-find components to meet their specific needs.

With the principle of “Quality Parts,Customers Priority,Honest Operation,and Considerate Service”,our business mainly focus on the distribution of electronic components. Line cards we deal with include Microchip,ALPS,ROHM,Xilinx,Pulse,ON,Everlight and Freescale. Main products comprise IC,Modules,Potentiometer,IC Socket,Relay,Connector.Our parts cover such applications as commercial,industrial, and automotives areas.

We are looking forward to setting up business relationship with you and hope to provide you with the best service and solution. Let us make a better world for our industry!



Contact us

Tel: +86-755-8981 8866 Fax: +86-755-8427 6832

Email & Skype: info@chipsmall.com Web: www.chipsmall.com

Address: A1208, Overseas Decoration Building, #122 Zhenhua RD., Futian, Shenzhen, China



Low voltage high performance NPN power transistor

Features

- Very low collector-emitter saturation voltage
- High current gain characteristic
- Fast switching speed

Applications

- Emergency lighting
- LED drive
- Motherboard and hard disk drive
- Mobile equipment
- DC-DC converter, voltage regulation

Description

The device is a NPN transistor manufactured using new "PB-HCD" (power bipolar high current density) technology. The resulting transistor shows exceptional high gain performances coupled with very low saturation voltage.

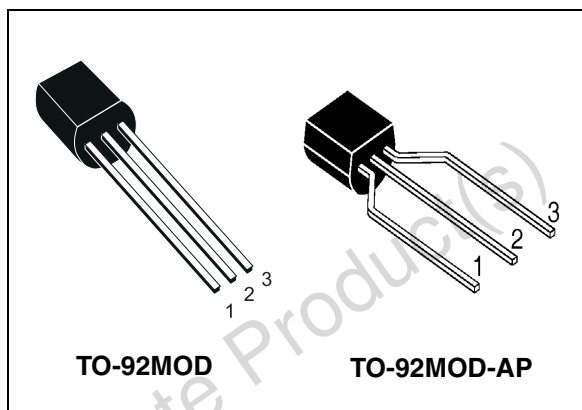

Figure 1. Internal schematic diagram

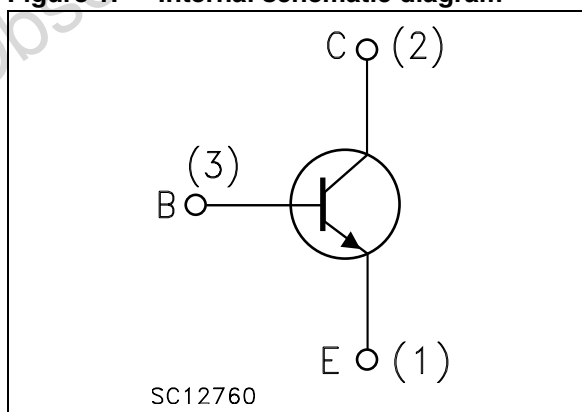

Table 1. Device summary

Order codes	Marking	Package	Packaging
2STL1525	2STL1525	TO-92MOD	Bag
2STL1525-AP	2STL1525	TO-92MOD-AP	Ammopack

1 Electrical ratings

Table 2. Absolute maximum ratings

Symbol	Parameter	Value	Unit
V_{CEX}	Collector-emitter voltage ($V_{BE} = -1.5$ V)	95	V
V_{CEO}	Collector-emitter voltage ($I_B = 0$)	25	V
V_{EBO}	Emitter-base voltage ($I_C = 0$)	5	V
I_C	Collector current	5	A
I_{CM}	Collector peak current ($t_P < 5$ ms)	10	A
I_B	Base current	1	A
P_{TOT}	Total dissipation at $T_{amb} = 25$ °C	1.5	W
T_{STG}	Storage temperature	-65 to 150	°C
T_J	Max. operating junction temperature	150	°C

Table 3. Thermal data

Symbol	Parameter	Value	Unit
R_{thJA}	Thermal resistance junction-ambient max	83	°C/W

2 Electrical characteristics

$T_{\text{case}} = 25\text{ }^{\circ}\text{C}$ unless otherwise specified.

Table 4. Electrical characteristics

Symbol	Parameter	Test conditions	Min.	Typ.	Max.	Unit
I_{CBO}	Collector cut-off current ($I_{\text{E}} = 0$)	$V_{\text{CB}} = 50\text{ V}$			0.1	μA
I_{EBO}	Emitter cut-off current ($I_{\text{C}} = 0$)	$V_{\text{EB}} = 4\text{ V}$			0.1	μA
$V_{(\text{BR})\text{CEX}}$	Collector-emitter breakdown voltage ($V_{\text{BE}} = -1.5\text{ V}$)	$I_{\text{C}} = 1\text{ mA}$	95			V
$V_{(\text{BR})\text{CEO}}^{(1)}$	Collector-emitter breakdown voltage ($I_{\text{B}} = 0$)	$I_{\text{C}} = 10\text{ mA}$	25			V
$V_{(\text{BR})\text{EBO}}$	Emitter-base breakdown voltage ($I_{\text{C}} = 0$)	$I_{\text{E}} = 100\text{ }\mu\text{A}$	5			V
$h_{\text{FE}}^{(1)}$	DC current gain	$I_{\text{C}} = 0.5\text{ A}$ $V_{\text{CE}} = 2\text{ V}$ $I_{\text{C}} = 3\text{ A}$ $V_{\text{CE}} = 2\text{ V}$ $I_{\text{C}} = 5\text{ A}$ $V_{\text{CE}} = 5\text{ V}$	150 100	150	500	
$V_{\text{CE}(\text{sat})}^{(1)}$	Collector-emitter saturation voltage	$I_{\text{C}} = 3\text{ A}$ $I_{\text{B}} = 300\text{ mA}$ $I_{\text{C}} = 3.5\text{ A}$ $I_{\text{B}} = 40\text{ mA}$		220	500	mV mV
$V_{\text{BE}(\text{sat})}^{(1)}$	Base-emitter saturation voltage	$I_{\text{C}} = 3\text{ A}$ $I_{\text{B}} = 300\text{ mA}$			1.2	V
C_{CBO}	Collector-base capacitance ($I_{\text{E}} = 0$)	$V_{\text{CB}} = 10\text{ V}$, $f = 1\text{ MHz}$		20		pF
f_{T}	Transition frequency	$V_{\text{CE}} = 10\text{ V}$ $I_{\text{C}} = 50\text{ mA}$		120		MHz
t_{on}	Resistive load Turn-on time	$I_{\text{C}} = 1.5\text{ A}$ $V_{\text{CC}} = 10\text{ V}$ $I_{\text{B}1} = -I_{\text{B}2} = 150\text{ mA}$		60		ns
t_{off}	Turn-off time			450		ns

1. Pulse test: pulse duration $\leq 300\text{ }\mu\text{s}$, duty cycle $\leq 2\%$

3 Package mechanical data

In order to meet environmental requirements, ST offers these devices in different grades of ECOPACK® packages, depending on their level of environmental compliance. ECOPACK® specifications, grade definitions and product status are available at: www.st.com. ECOPACK® is an ST trademark.

Table 5. TO-92MOD mechanical data

Dim.	mm.		
	Min.	Typ.	Max.
A	4.7		5.1
A1	1.730		2.030
b	0.4		0.6
b1	0.9		1.1
c	0.4		0.5
D	5.8		6.2
D1	4.0		
E	8.4		8.8
e		1.5	
e1	2.9		3.1
L	13.8		14.2
K			1.6
h	0.0		0.380

Figure 2. TO-92MOD drawing mechanical data

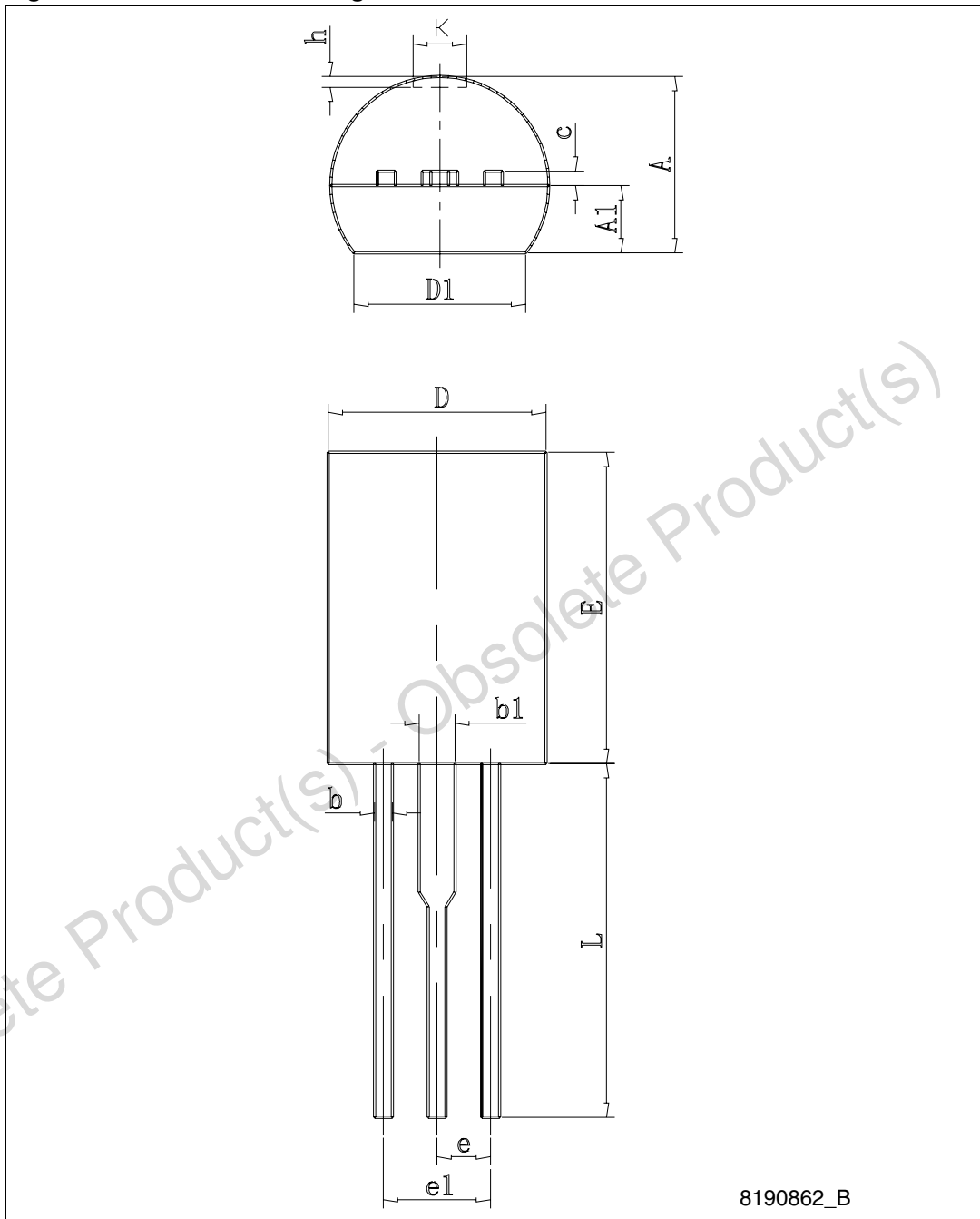

8190862_B

TO-92MOD-AP ammpack dimension

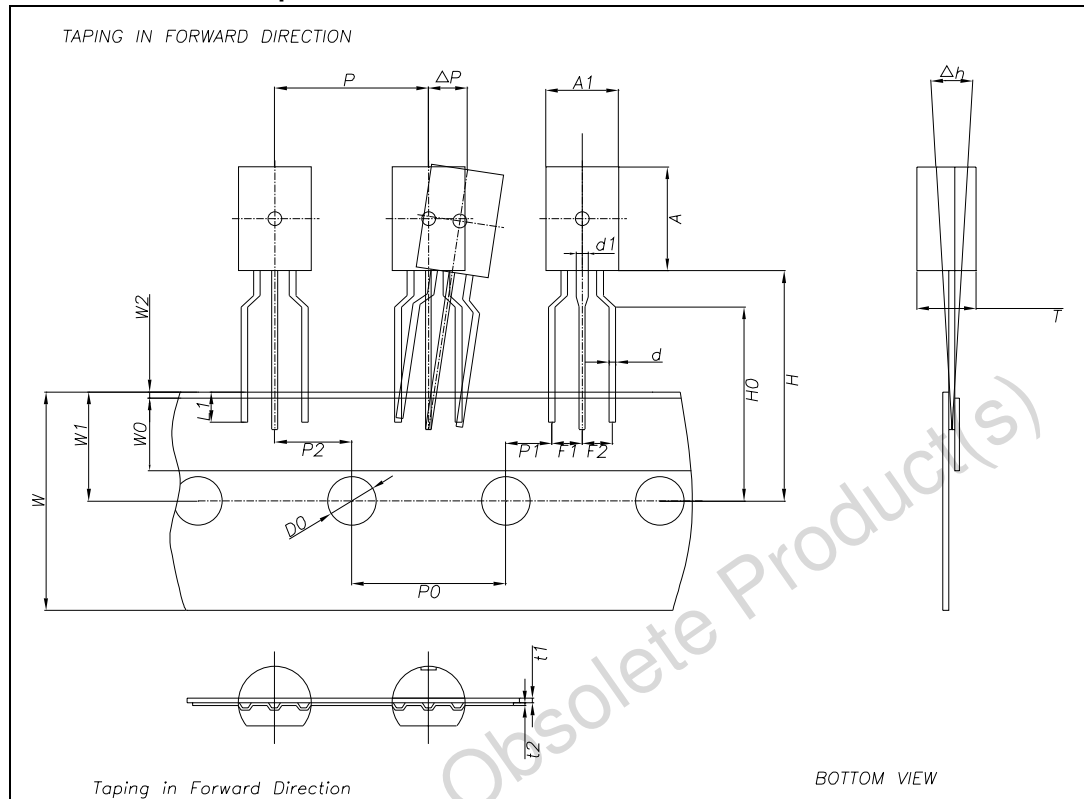

Taping in Forward Direction

BOTTOM VIEW

ITEM	SYMBOL	VALUE & TOLERANCE
Body Width	A1	6.0 ± 0.2
Body Eighth	A	8.6 ± 0.2
Body Thickness	T	4.9 ± 0.2
Lead Wire Diameter	d	0.5 ± 0.05
Lead Wire Diameter 1	d1	1.0 ± 0.05
Pitch of component	P	12.7 ± 0.3
Feed Hole Pitch	P0	12.7 ± 0.2
Hole center to component center	P2	6.35 ± 0.3
Lead to lead distance	F1, F2	2.5 ± 0.3
Component alignment F-R	Δh	0 ± 1.0
Type width	W	18.0 +1.0, -0.5
Hole down tape width	W0	6.0 ± 0.5
Hole position	W1	9.0 ± 0.5
Hole down tape position	W2	1.0 MAX
Height of component from tape center	H	19.0 ± 1.0
Lead wire clinch height	H0	16.0 ± 0.5
Lead wire (tape portion)	L1	2.5 MIN
Feed hole diameter	D0	4.0 ± 0.2
Taped Lead Thickness	t1	0.4 ± 0.05
Carrier tape Thickness	t2	0.2 ± 0.05
Position of Hole	P1	3.85 ± 0.03
Component alignment	ΔP	0 ± 1.0

Unit: mm

*Dimensions in mm

*Cumulative pitch error: 1.0mm/20 pitches

*Grong paper tape: 0.5mm+/-0.1

8231868_B

4 Revision history

Table 6. Document revision history

Date	Revision	Changes
31-Jul-2009	1	Initial release.
01-Dec-2010	2	Document status promoted from preliminary data to datasheet. Updated package mechanical data Table 5 on page 4 and Figure 2 on page 5 .

Obsolete Product(s) - Obsolete Product(s)

Please Read Carefully:

Information in this document is provided solely in connection with ST products. STMicroelectronics NV and its subsidiaries ("ST") reserve the right to make changes, corrections, modifications or improvements, to this document, and the products and services described herein at any time, without notice.

All ST products are sold pursuant to ST's terms and conditions of sale.

Purchasers are solely responsible for the choice, selection and use of the ST products and services described herein, and ST assumes no liability whatsoever relating to the choice, selection or use of the ST products and services described herein.

No license, express or implied, by estoppel or otherwise, to any intellectual property rights is granted under this document. If any part of this document refers to any third party products or services it shall not be deemed a license grant by ST for the use of such third party products or services, or any intellectual property contained therein or considered as a warranty covering the use in any manner whatsoever of such third party products or services or any intellectual property contained therein.

UNLESS OTHERWISE SET FORTH IN ST'S TERMS AND CONDITIONS OF SALE ST DISCLAIMS ANY EXPRESS OR IMPLIED WARRANTY WITH RESPECT TO THE USE AND/OR SALE OF ST PRODUCTS INCLUDING WITHOUT LIMITATION IMPLIED WARRANTIES OF MERCHANTABILITY, FITNESS FOR A PARTICULAR PURPOSE (AND THEIR EQUIVALENTS UNDER THE LAWS OF ANY JURISDICTION), OR INFRINGEMENT OF ANY PATENT, COPYRIGHT OR OTHER INTELLECTUAL PROPERTY RIGHT.

UNLESS EXPRESSLY APPROVED IN WRITING BY AN AUTHORIZED ST REPRESENTATIVE, ST PRODUCTS ARE NOT RECOMMENDED, AUTHORIZED OR WARRANTED FOR USE IN MILITARY, AIR CRAFT, SPACE, LIFE SAVING, OR LIFE SUSTAINING APPLICATIONS, NOR IN PRODUCTS OR SYSTEMS WHERE FAILURE OR MALFUNCTION MAY RESULT IN PERSONAL INJURY, DEATH, OR SEVERE PROPERTY OR ENVIRONMENTAL DAMAGE. ST PRODUCTS WHICH ARE NOT SPECIFIED AS "AUTOMOTIVE GRADE" MAY ONLY BE USED IN AUTOMOTIVE APPLICATIONS AT USER'S OWN RISK.

Resale of ST products with provisions different from the statements and/or technical features set forth in this document shall immediately void any warranty granted by ST for the ST product or service described herein and shall not create or extend in any manner whatsoever, any liability of ST.

ST and the ST logo are trademarks or registered trademarks of ST in various countries.

Information in this document supersedes and replaces all information previously supplied.

The ST logo is a registered trademark of STMicroelectronics. All other names are the property of their respective owners.

© 2010 STMicroelectronics - All rights reserved

STMicroelectronics group of companies

Australia - Belgium - Brazil - Canada - China - Czech Republic - Finland - France - Germany - Hong Kong - India - Israel - Italy - Japan - Malaysia - Malta - Morocco - Philippines - Singapore - Spain - Sweden - Switzerland - United Kingdom - United States of America

www.st.com