



Chipsmall Limited consists of a professional team with an average of over 10 year of expertise in the distribution of electronic components. Based in Hongkong, we have already established firm and mutual-benefit business relationships with customers from,Europe,America and south Asia,supplying obsolete and hard-to-find components to meet their specific needs.

With the principle of "Quality Parts,Customers Priority,Honest Operation,and Considerate Service",our business mainly focus on the distribution of electronic components. Line cards we deal with include Microchip,ALPS,ROHM,Xilinx,Pulse,ON,Everlight and Freescale. Main products comprise IC,Modules,Potentiometer,IC Socket,Relay,Connector.Our parts cover such applications as commercial,industrial, and automotives areas.

We are looking forward to setting up business relationship with you and hope to provide you with the best service and solution. Let us make a better world for our industry!



Contact us

Tel: +86-755-8981 8866 Fax: +86-755-8427 6832

Email & Skype: info@chipsmall.com Web: www.chipsmall.com

Address: A1208, Overseas Decoration Building, #122 Zhenhua RD., Futian, Shenzhen, China





2STD1360, 2STF1360, 2STN1360

Low voltage fast-switching NPN power transistors

Datasheet – production data

Features

- Very low collector-emitter saturation voltage
- High current gain characteristic
- Fast-switching speed

Applications

- Emergency lighting
- LED
- Voltage regulation
- Relay drive

Description

This device is an NPN transistor manufactured using new low voltage planar technology with double metal process. The result is a transistor which boasts exceptionally high gain performance coupled with very low saturation voltage.

The complementary PNP types are the 2STD2360T4, the 2STF2360 and the 2STN2360.

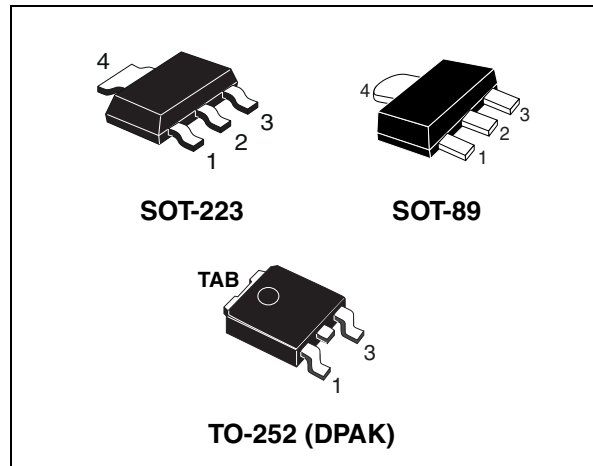

Figure 1. Internal schematic diagram

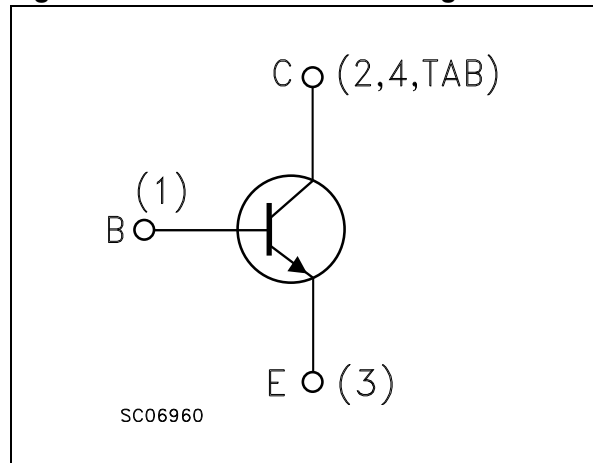

Table 1. Device summary

Order codes	Marking	Packages	Packaging
2STD1360T4	2STD1360	DPAK	Tape and reel
2STF1360	1360	SOT-89	Tape and reel
2STN1360	N1360	SOT-223	Tape and reel

1 Absolute maximum ratings

Table 2. Absolute maximum ratings

Symbol	Parameter	Value			Unit
		2STD1360	2STF1360	2STN1360	
		DKPAK	SOT-89	SOT-223	
V_{CBO}	Collector-base voltage ($I_E = 0$)	80			V
V_{CEO}	Collector-emitter voltage ($I_B = 0$)	60			V
V_{EBO}	Emitter-base voltage ($I_C = 0$)	6			V
I_C	Collector current	3			A
I_{CM}	Collector peak current ($t_p < 5$ ms)	5			A
I_B	Base current	0.2			A
I_{BM}	Base peak current ($t_p < 5$ ms)	0.4			A
P_{TOT}	Total dissipation at $T_{amb} = 25$ °C	15	1.4	1.6	W
T_{stg}	Storage temperature	-65 to 150			°C
T_J	Max. operating junction temperature	150			°C

Table 3. Thermal data

Symbol	Parameter	DKPAK	SOT-89	SOT-223	Unit	
$R_{thJA}^{(1)}$	Thermal resistance junction-ambient	Max	8.3	89	78	°C/W

1. Device mounted on a PCB area of 1 cm²

2 Electrical characteristics

$T_{CASE} = 25^{\circ}\text{C}$; unless otherwise specified.

Table 4. Electrical characteristics

Symbol	Parameter	Test conditions	Min.	Typ.	Max.	Unit
I_{CBO}	Collector cut-off current ($I_E = 0$)	$V_{CB} = 80\text{ V}$			100	nA
I_{EBO}	Emitter cut-off current ($I_C = 0$)	$V_{EB} = 6\text{ V}$			100	nA
$V_{BE(on)}$	Base-emitter on voltage	$V_{CE} = 2\text{ V}$ $I_C = 100\text{ mA}$	630	650	730	mV
$V_{CE(sat)}^{(1)}$	Collector-emitter saturation voltage	$I_C = 2\text{ A}$ $I_B = 100\text{ mA}$ $I_C = 3\text{ A}$ $I_B = 150\text{ mA}$		130 180	300 500	mV mV
$V_{BE(sat)}^{(1)}$	Base-emitter saturation voltage	$I_C = 2\text{ A}$ $I_B = 100\text{ mA}$		0.9	1.2	V
$h_{FE}^{(1)}$	DC current gain	$I_C = 100\text{ mA}$ $V_{CE} = 2\text{ V}$ $I_C = 1\text{ A}$ $V_{CE} = 2\text{ V}$	80 160		400	
t_d	Resistive load Delay time	$I_C = 3\text{ A}$ $V_{CC} = 10\text{ V}$ $I_{B(on)} = - I_{B(off)} = 300\text{ mA}$ $V_{BE(off)} = - 5\text{ V}$		17	20	ns
t_r	Rise time			81	100	ns
t_s	Storage time			620	720	ns
t_f	Fall time			54	65	ns
f_T	Transition frequency	$I_C = 0.1\text{ A}$ $V_{CE} = 10\text{ V}$		130		MHz

1. Pulse test: pulse duration $\leq 300\text{ }\mu\text{s}$, duty cycle $\leq 2\%$

2.1 Typical characteristics (curves)

Figure 2. DC current gain ($V_{CE} = 5\text{ V}$)

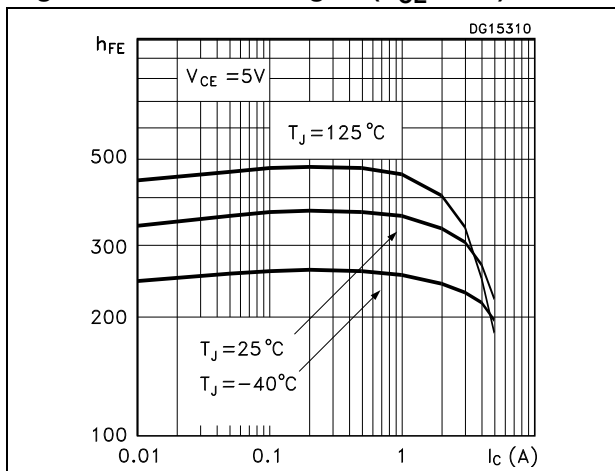

Figure 3. DC current gain ($V_{CE} = 2\text{ V}$)

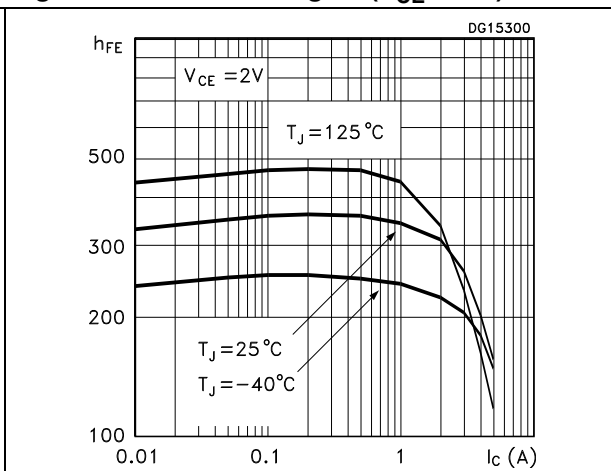

Figure 4. Collector emitter saturation voltage Figure 5. Base emitter saturation voltage

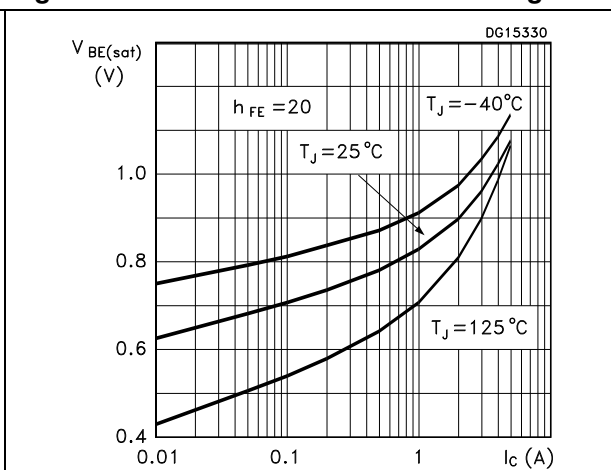
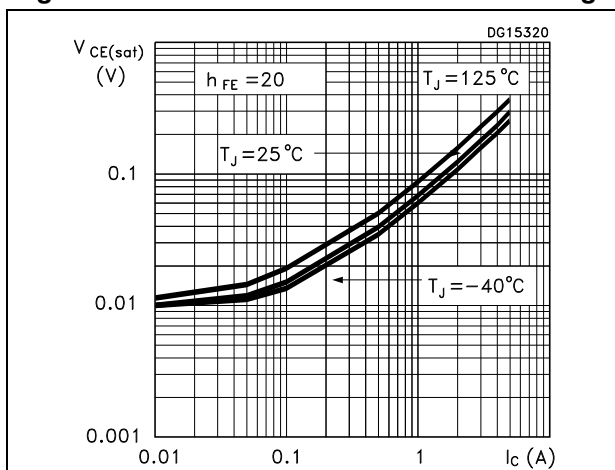

Figure 6. Resistive load switching on

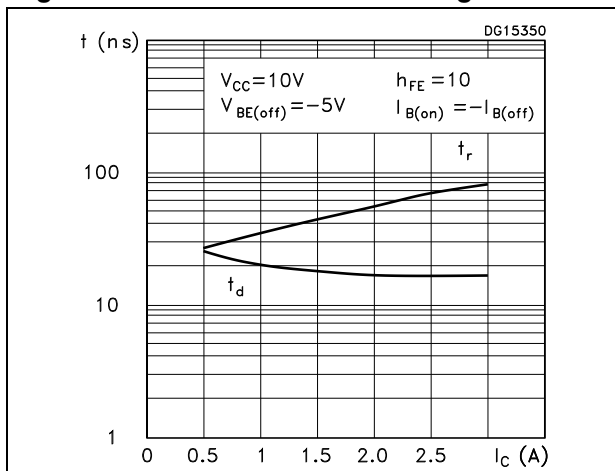

Figure 7. Resistive load switching off

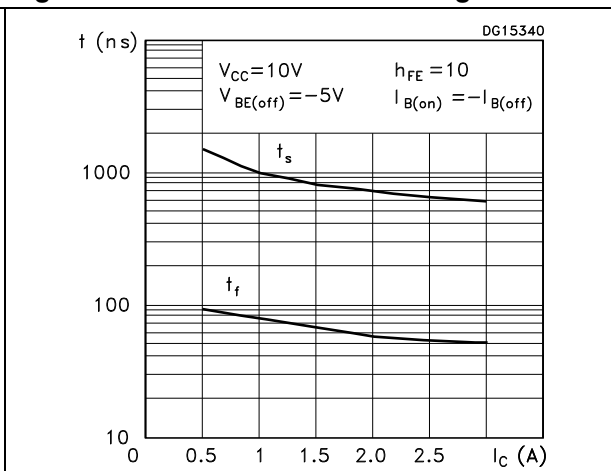
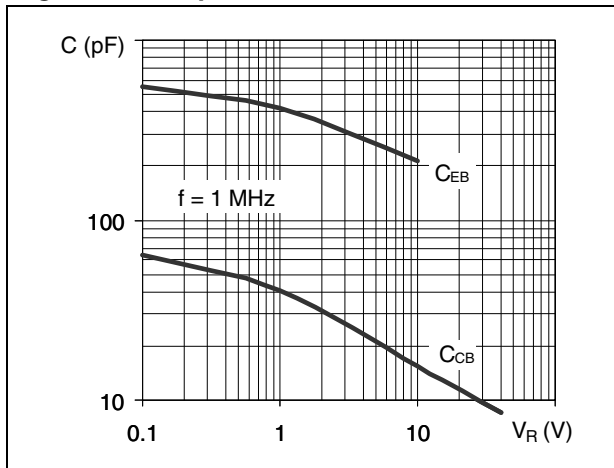
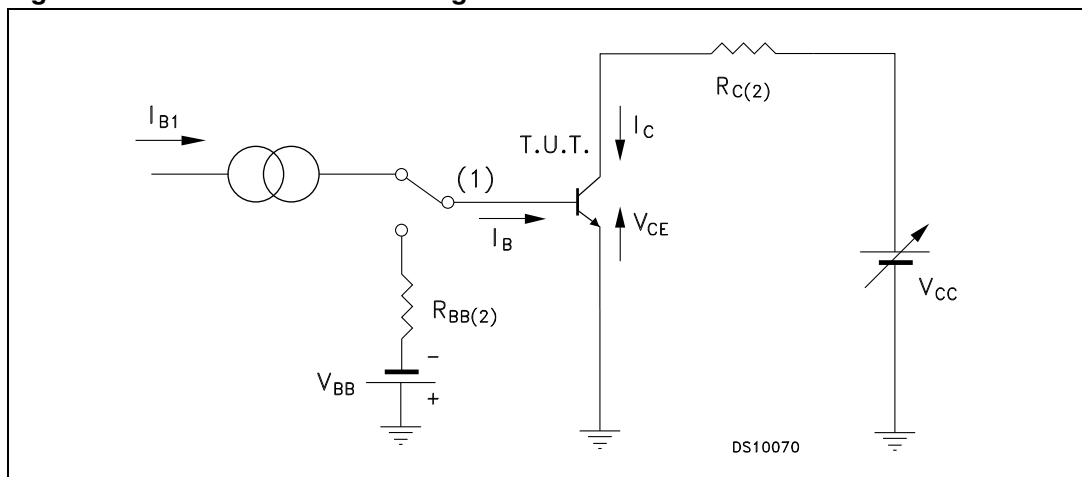

Figure 8. Capacitance



2.2 Test circuits

Figure 9. Resistive load switching



1. Fast electronic switch
2. Non-inductive resistor

3 Package mechanical data

In order to meet environmental requirements, ST offers these devices in different grades of ECOPACK[®] packages, depending on their level of environmental compliance. ECOPACK[®] specifications, grade definitions and product status are available at: www.st.com. ECOPACK[®] is an ST trademark.

Table 5. DPAK (TO-252) mechanical data

Dim.	mm		
	Min.	Typ.	Max.
A	2.20		2.40
A1	0.90		1.10
A2	0.03		0.23
b	0.64		0.90
b4	5.20		5.40
c	0.45		0.60
c2	0.48		0.60
D	6.00		6.20
D1		5.10	
E	6.40		6.60
E1		4.70	
e		2.28	
e1	4.40		4.60
H	9.35		10.10
L	1		
L1		2.80	
L2		0.80	
L4	0.60		1
R		0.20	
V2	0°		8°

Figure 10. DPAK (TO-252) drawing

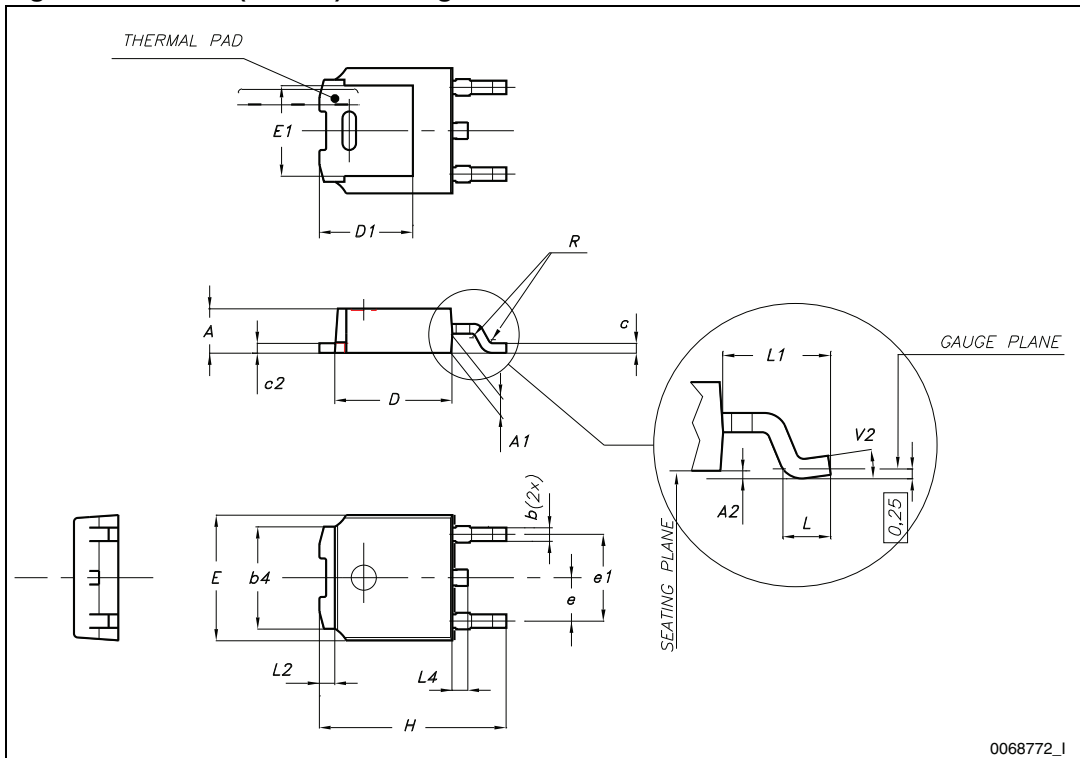
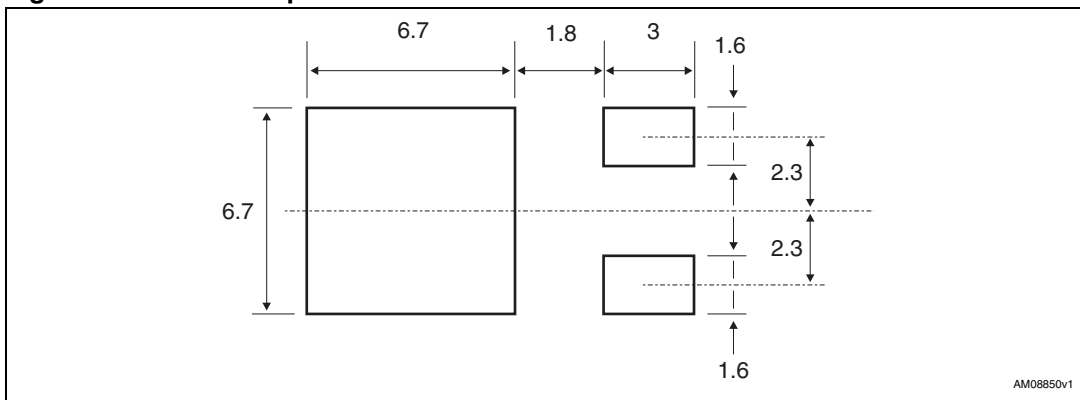

Figure 11. DPAK footprint^(a)



a. All dimensions are in millimeters

Table 6. DPAK (TO-252) tape and reel mechanical data

Tape			Reel		
Dim.	mm		Dim.	mm	
	Min.	Max.		Min.	Max.
A0	6.8	7	A		330
B0	10.4	10.6	B	1.5	
B1		12.1	C	12.8	13.2
D	1.5	1.6	D	20.2	
D1	1.5		G	16.4	18.4
E	1.65	1.85	N	50	
F	7.4	7.6	T		22.4
K0	2.55	2.75			
P0	3.9	4.1	Base qty.		2500
P1	7.9	8.1	Bulk qty.		2500
P2	1.9	2.1			
R	40				
T	0.25	0.35			
W	15.7	16.3			

Figure 12. Tape for DPAK (TO-252)

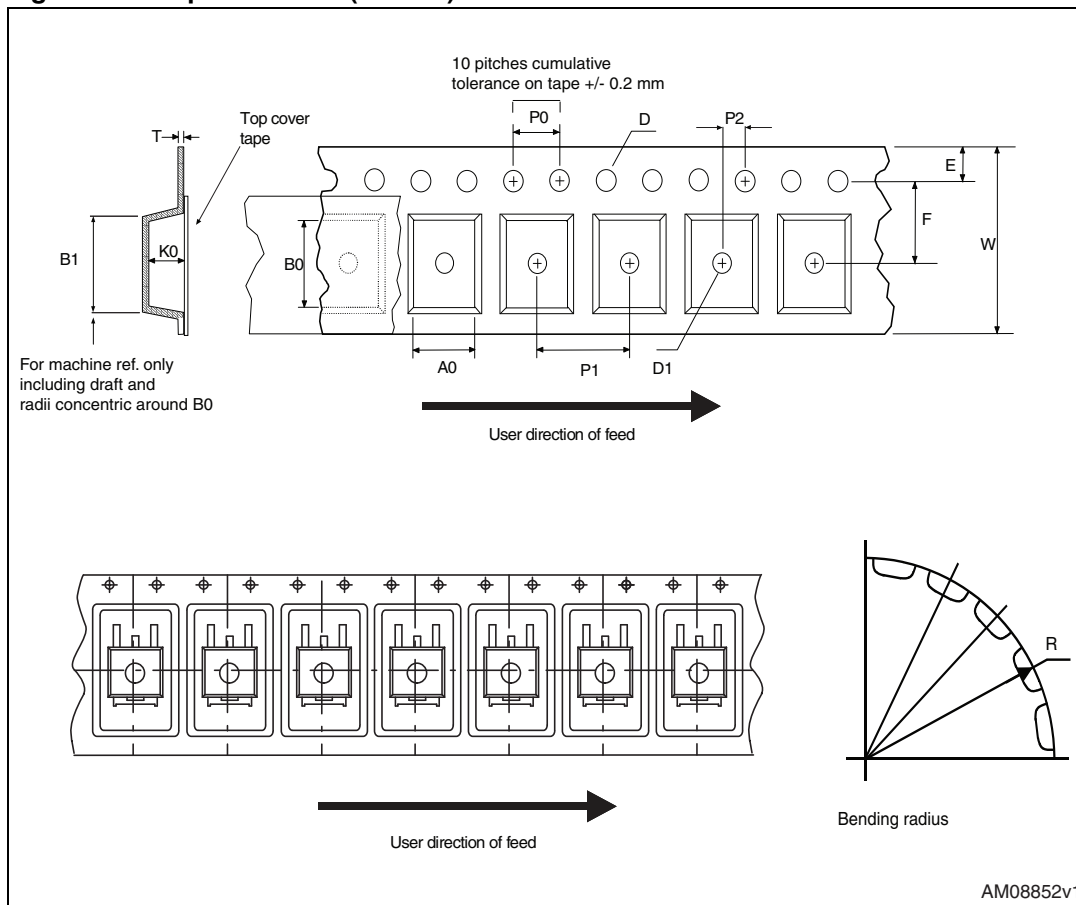

Figure 13. Reel for DPAK (TO-252)

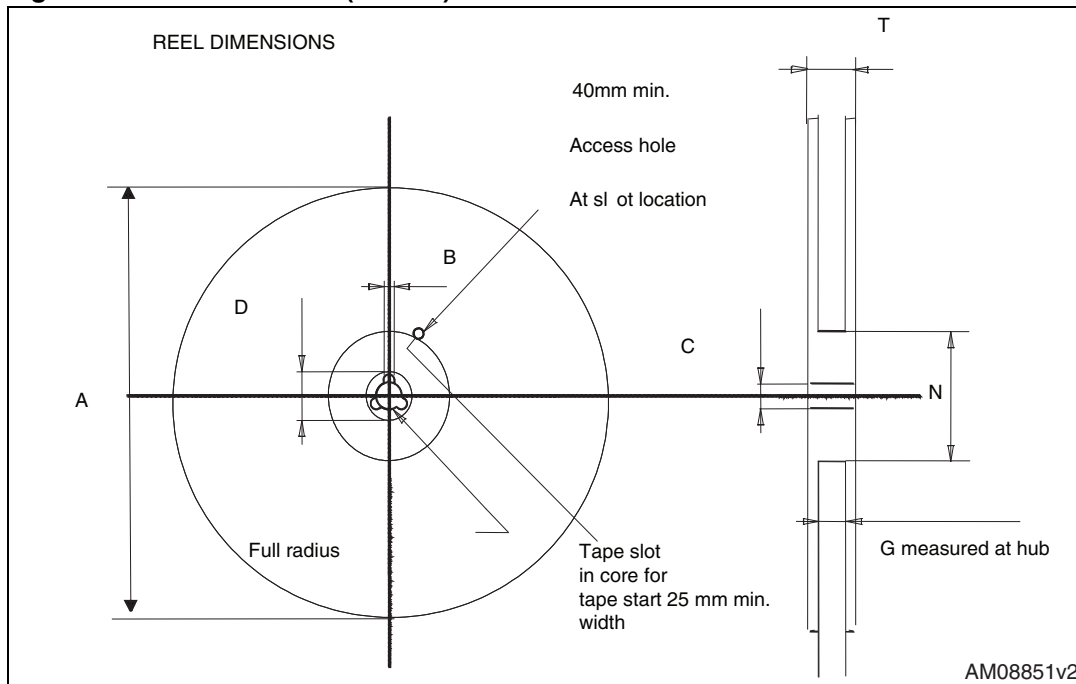

Table 7. SOT-89 mechanical data

Dim.	mm		
	Min.	Typ.	Max.
A	1.40		1.60
B	0.44		0.56
B1	0.36		0.48
C	0.35		0.44
C1	0.35		0.44
D	4.40		4.60
D1	1.62		1.83
D3		0.90	
E	2.29		2.60
e	1.42		1.57
e1	2.92		3.07
H	3.94		4.25
H1	2.70		3.10
K	1°		8°
L	0.89		1.20
R		0.25	
β		90°	

Figure 14. SOT-89 drawings

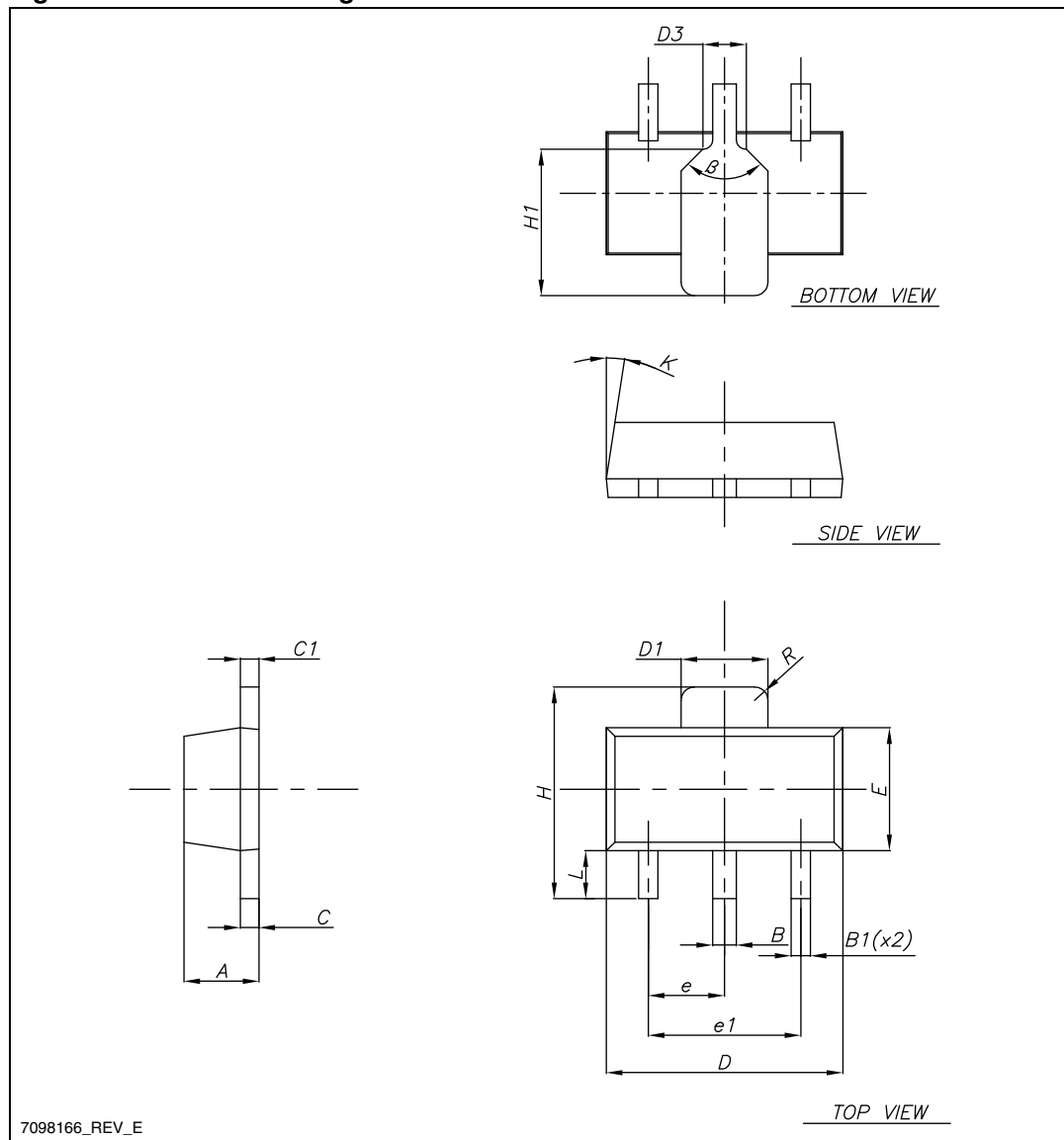

Figure 15. SOT-89 recommended footprint

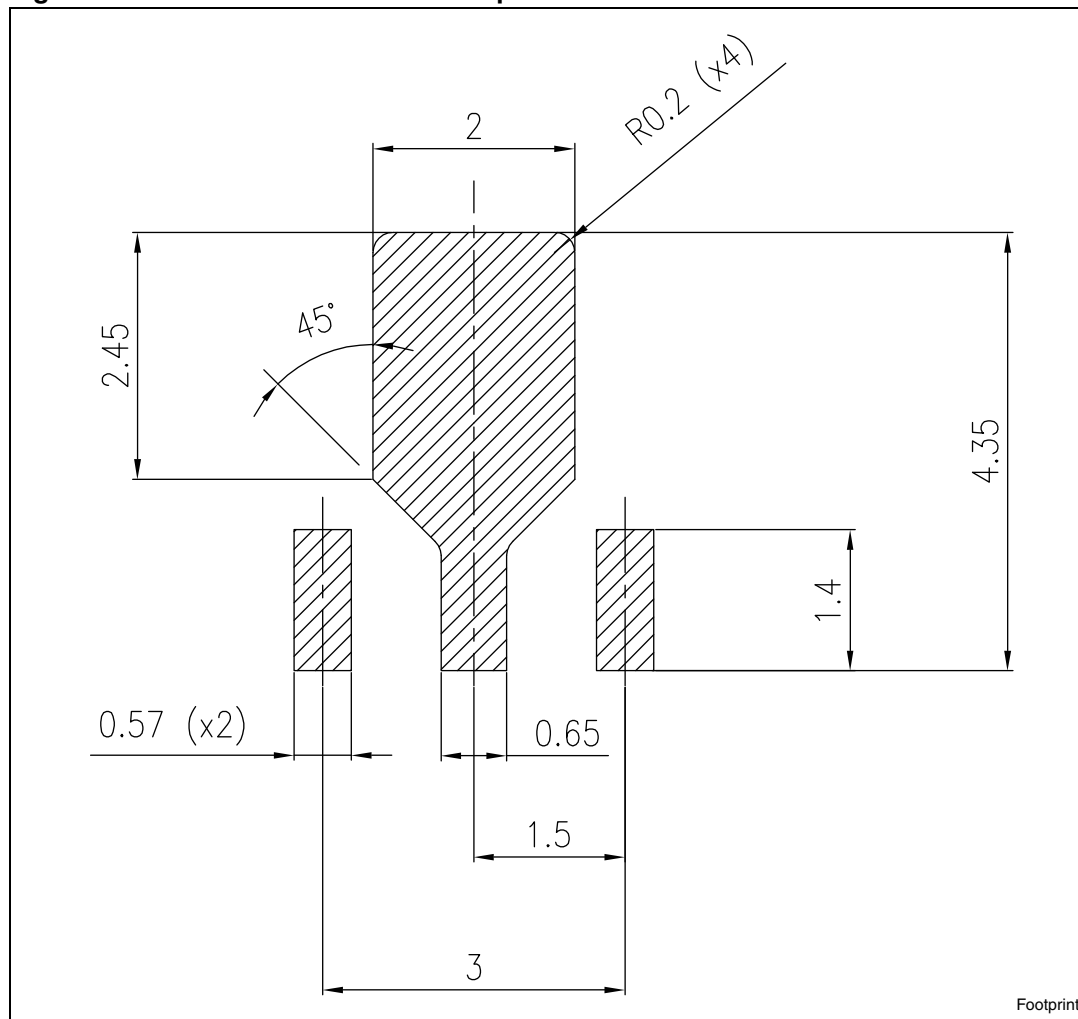
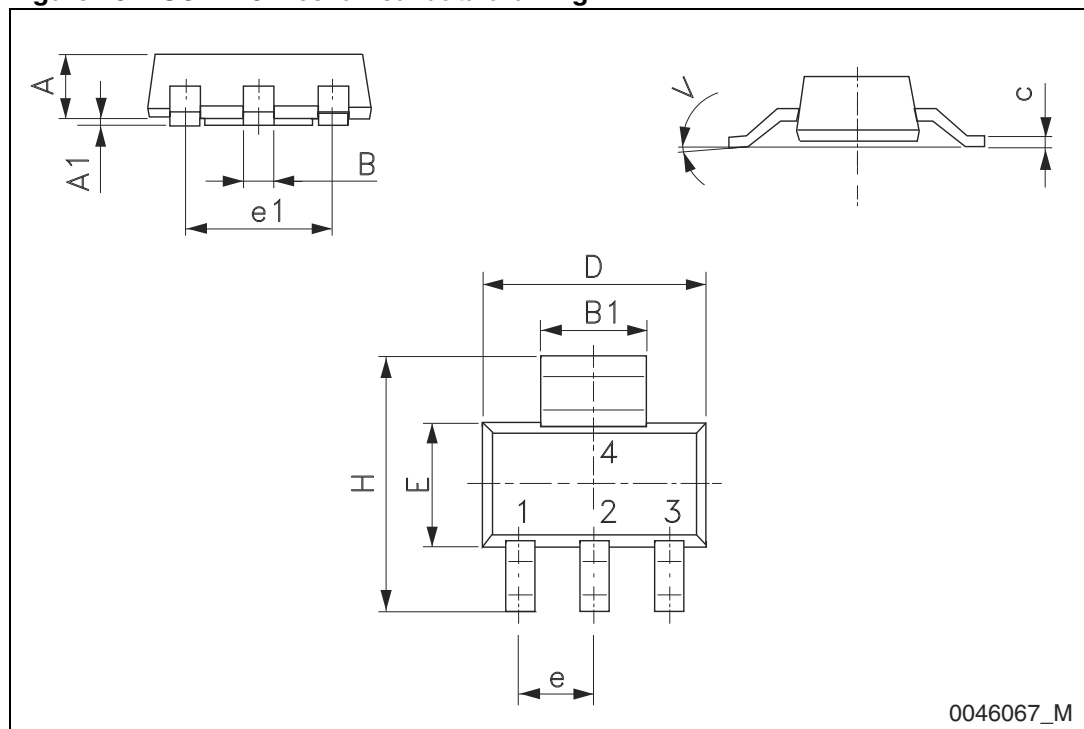

Table 8. SOT-223 mechanical data

Dim.	mm		
	Min.	Typ.	Max.
A			1.80
A1	0.02		0.1
B	0.60	0.70	0.85
B1	2.90	3.00	3.15
c	0.24	0.26	0.35
D	6.30	6.50	6.70
e		2.30	
e1		4.60	
E	3.30	3.50	3.70
H	6.70	7.00	7.30
V			10°

Figure 16. SOT-223 mechanical data drawing



0046067_M

4 Revision history

Table 9. Document revision history

Date	Revision	Changes
21-Nov-2005	1	Initial release
09-Oct-2009	2	Added 2STD1360T4 in TO-252 (DPAK) package
13-Aug-2012	3	Modified: marking for DPAK in Table 1

Please Read Carefully:

Information in this document is provided solely in connection with ST products. STMicroelectronics NV and its subsidiaries ("ST") reserve the right to make changes, corrections, modifications or improvements, to this document, and the products and services described herein at any time, without notice.

All ST products are sold pursuant to ST's terms and conditions of sale.

Purchasers are solely responsible for the choice, selection and use of the ST products and services described herein, and ST assumes no liability whatsoever relating to the choice, selection or use of the ST products and services described herein.

No license, express or implied, by estoppel or otherwise, to any intellectual property rights is granted under this document. If any part of this document refers to any third party products or services it shall not be deemed a license grant by ST for the use of such third party products or services, or any intellectual property contained therein or considered as a warranty covering the use in any manner whatsoever of such third party products or services or any intellectual property contained therein.

UNLESS OTHERWISE SET FORTH IN ST'S TERMS AND CONDITIONS OF SALE ST DISCLAIMS ANY EXPRESS OR IMPLIED WARRANTY WITH RESPECT TO THE USE AND/OR SALE OF ST PRODUCTS INCLUDING WITHOUT LIMITATION IMPLIED WARRANTIES OF MERCHANTABILITY, FITNESS FOR A PARTICULAR PURPOSE (AND THEIR EQUIVALENTS UNDER THE LAWS OF ANY JURISDICTION), OR INFRINGEMENT OF ANY PATENT, COPYRIGHT OR OTHER INTELLECTUAL PROPERTY RIGHT.

UNLESS EXPRESSLY APPROVED IN WRITING BY TWO AUTHORIZED ST REPRESENTATIVES, ST PRODUCTS ARE NOT RECOMMENDED, AUTHORIZED OR WARRANTED FOR USE IN MILITARY, AIR CRAFT, SPACE, LIFE SAVING, OR LIFE SUSTAINING APPLICATIONS, NOR IN PRODUCTS OR SYSTEMS WHERE FAILURE OR MALFUNCTION MAY RESULT IN PERSONAL INJURY, DEATH, OR SEVERE PROPERTY OR ENVIRONMENTAL DAMAGE. ST PRODUCTS WHICH ARE NOT SPECIFIED AS "AUTOMOTIVE GRADE" MAY ONLY BE USED IN AUTOMOTIVE APPLICATIONS AT USER'S OWN RISK.

Resale of ST products with provisions different from the statements and/or technical features set forth in this document shall immediately void any warranty granted by ST for the ST product or service described herein and shall not create or extend in any manner whatsoever, any liability of ST.

ST and the ST logo are trademarks or registered trademarks of ST in various countries.

Information in this document supersedes and replaces all information previously supplied.

The ST logo is a registered trademark of STMicroelectronics. All other names are the property of their respective owners.

© 2012 STMicroelectronics - All rights reserved

STMicroelectronics group of companies

Australia - Belgium - Brazil - Canada - China - Czech Republic - Finland - France - Germany - Hong Kong - India - Israel - Italy - Japan - Malaysia - Malta - Morocco - Philippines - Singapore - Spain - Sweden - Switzerland - United Kingdom - United States of America

www.st.com