



Chipsmall Limited consists of a professional team with an average of over 10 year of expertise in the distribution of electronic components. Based in Hongkong, we have already established firm and mutual-benefit business relationships with customers from,Europe,America and south Asia,supplying obsolete and hard-to-find components to meet their specific needs.

With the principle of "Quality Parts,Customers Priority,Honest Operation,and Considerate Service",our business mainly focus on the distribution of electronic components. Line cards we deal with include Microchip,ALPS,ROHM,Xilinx,Pulse,ON,Everlight and Freescale. Main products comprise IC,Modules,Potentiometer,IC Socket,Relay,Connector.Our parts cover such applications as commercial,industrial, and automotives areas.

We are looking forward to setting up business relationship with you and hope to provide you with the best service and solution. Let us make a better world for our industry!



## Contact us

Tel: +86-755-8981 8866 Fax: +86-755-8427 6832

Email & Skype: info@chipsmall.com Web: www.chipsmall.com

Address: A1208, Overseas Decoration Building, #122 Zhenhua RD., Futian, Shenzhen, China



REVISION(S)			
LTR	DESCRIPTION	INIT	APP'D
O	ECN: 0S60-0122-04	E.T 05/07/04	B.P 05/07/04
A	ECN: 0S60-0181-04	E.T 7/12/04	B.P 7/14/04
B	ECR-06-017841	E.T 7/25/06	V.K 7/25/06

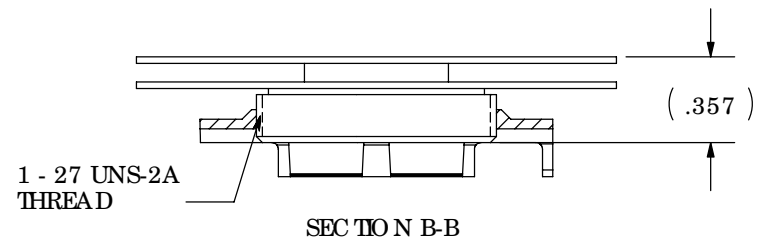
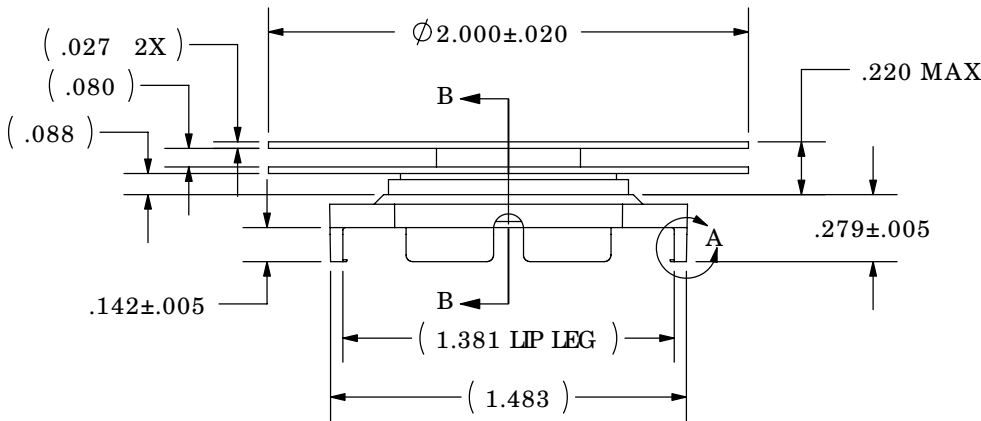
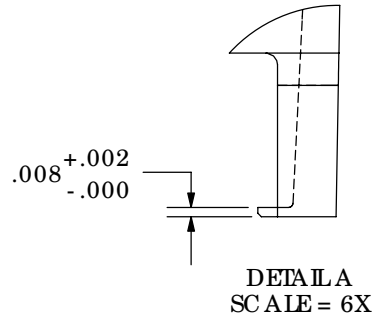
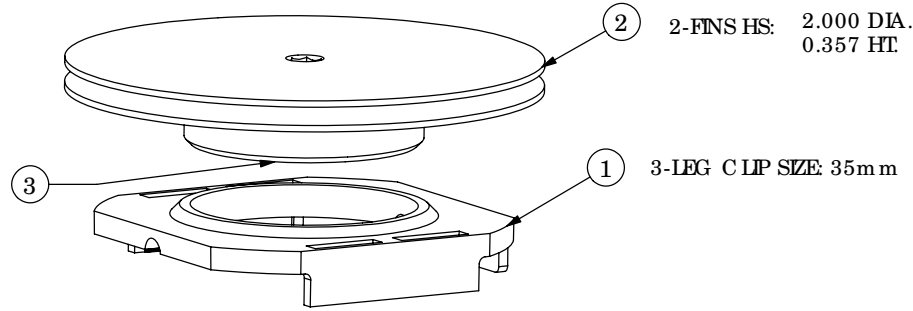

- MATERIAL:  
HEAT SINK: ALUM. (BLACK ANODIZE)  
CLIP: BLACK PEI (UL94-VO)
- BEFORE THE HEATSINK APPLICATION, THE USER SHOULD IDENTIFY THE SPECIFICATION OF MAXIMUM LOAD ON THE BGA PACKAGE.  
  
HEATSINK TORQUE SPECIFICATIONS CONVERTED TO FORCE.  
  
BARE DIE PACKAGE:  
2.0 POUND-FORCE INCH TORQUE = 8.1 POUND-FORCE (0.23 NEWTON METER TORQUE = 36.03 NEWTON)  
2.5 POUND-FORCE INCH TORQUE = 10.1 POUND-FORCE (0.28 NEWTON METER TORQUE = 44.93 NEWTON)  
  
FULL SIZE LID PACKAGE:  
2.0 POUND-FORCE INCH TORQUE = 6.9 POUND-FORCE (0.23 NEWTON METER TORQUE = 30.69 NEWTON)  
2.5 POUND-FORCE INCH TORQUE = 8.7 POUND-FORCE (0.28 NEWTON METER TORQUE = 38.70 NEWTON)
- REMOVE CLIP WITH REMOVAL TOOL P/N: 1542616-1
- RoHS COMPLIANT AND CERTIFIED.

**CUSTOMER DRAWING**  
SPECIFICATIONS ARE SUBJECT TO CHANGE WITHOUT NOTICE

ITEM	DESCRIPTION	QTY
1	MOUNTING CLIP	1
2	HEAT SINK	1
3	INTERFACE	1

<b>DO NOT SCALE</b>	<b>tyco</b> / Electronics		Attleboro Falls Massachusetts 02763		CONFIDENTIAL PROPERTY OF TYCO ELECTRONICS. NOT TO BE REPRODUCED OR USED FOR ANY PURPOSES EXCEPT AS AUTHORIZED IN WRITING BY AN AUTHORIZED OFFICIAL OF TYCO. MUST BE RETURNED TO TYCO ON DEMAND, ON COMPLETION OF ORDERS OR OTHER PURPOSES FOR WHICH INTENT.		TITLE <b>35mm HEATSINK ASSEMBLY</b>		
	UNLESS OTHERWISE SPECIFIED TO TOLERANCES ARE: .XX ± .XXX ± .XXXX ± ANGLES ± °	DRAWN BY: ETAO	DATE: 05/07/04	MATERIAL: SEE NOTE		DIMENSIONS ARE IN: INCHES		SCALE: 1.25:1	PART NO: <b>3-1542009-2</b>
	ENGINEER: B. PETROCELLI	DATE: 05/07/04	FINISH: SEE NOTE		SIZE: A	DWG. NO. <b>C-3-1542009-2</b>	SHEET: 1 OF 1	REV: <b>B</b>	
	FILENAME	PROJECT	SYSTEM						