



Chipsmall Limited consists of a professional team with an average of over 10 year of expertise in the distribution of electronic components. Based in Hongkong, we have already established firm and mutual-benefit business relationships with customers from,Europe,America and south Asia,supplying obsolete and hard-to-find components to meet their specific needs.

With the principle of “Quality Parts,Customers Priority,Honest Operation,and Considerate Service”,our business mainly focus on the distribution of electronic components. Line cards we deal with include Microchip,ALPS,ROHM,Xilinx,Pulse,ON,Everlight and Freescale. Main products comprise IC,Modules,Potentiometer,IC Socket,Relay,Connector.Our parts cover such applications as commercial,industrial, and automotives areas.

We are looking forward to setting up business relationship with you and hope to provide you with the best service and solution. Let us make a better world for our industry!



Contact us

Tel: +86-755-8981 8866 Fax: +86-755-8427 6832

Email & Skype: info@chipsmall.com Web: www.chipsmall.com

Address: A1208, Overseas Decoration Building, #122 Zhenhua RD., Futian, Shenzhen, China



ZONE	LTR	DESCRIPTION	DATE	APPROVED
	P1	REVISED PER ECO-11-005294	07APR11	HMR

NUMBER 330854

WIRE SIZE (AWG)	CLIP	"J"	PNEUMATIC TOOL	MANUAL SERVICE TOOL
	COLOR CODE		1000 CLIPS/REEL	40 STRIPS 25 EACH
20	YELLOW	.051	2-330854-6	2-330854-4
24	RED	.029	2-330854-9	4-330854-1

CLIP SELECTION CHART

INSULATION DIA. RANGE	MANDREL NUMBER	
	PNEUMATIC TOOL (69585-1)	MANUAL SERVICE TOOL (69702)
.066-.075	69542	69561-1
.076-.085	69542-1	69561-1
.055-.065	69542-8	69561-4

MANDREL SELECTION CHART

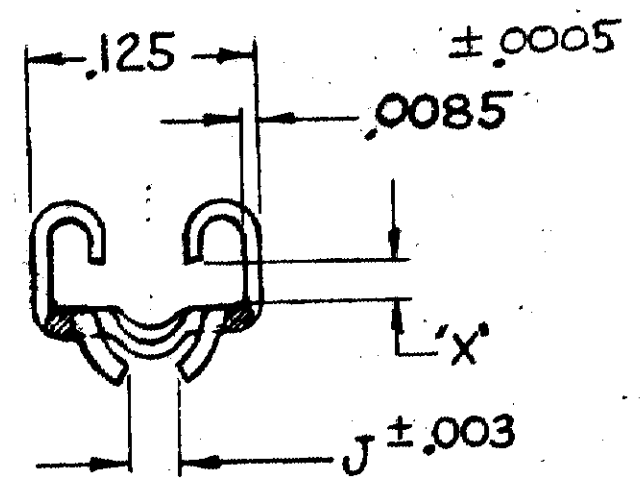
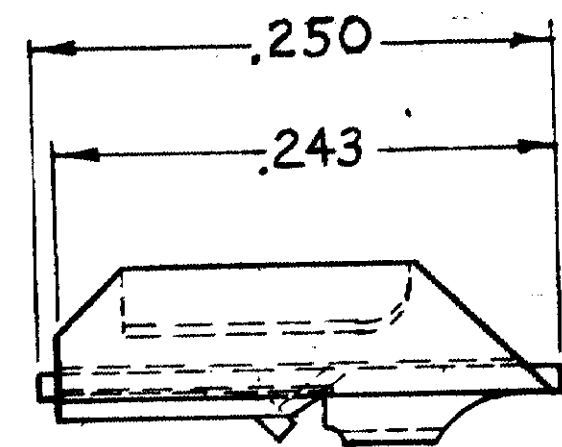

NOTE: 1. TIN PLATE (MIL-T-10727) .0001 MIN THK

SUGGESTED GAGE DESIGN

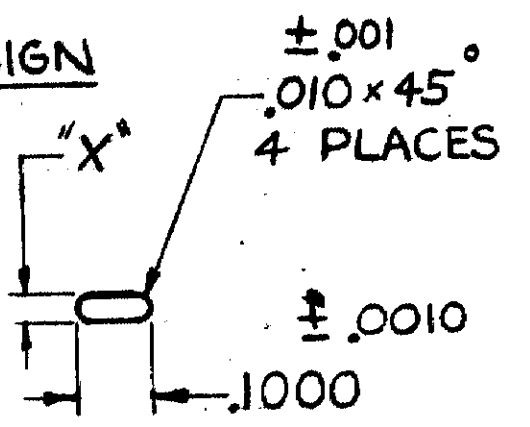
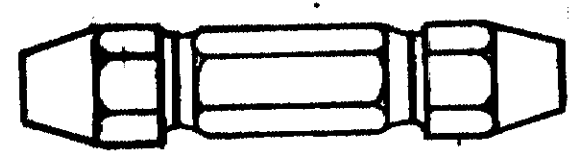
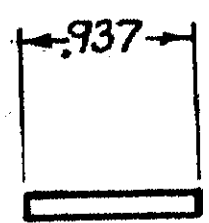

SIDE VIEW OF GAGE

DOUBLE END HANDLE A.G.D STD.

END VIEW OF GAGE

SCALE: 1-1

NOTE: GAGE TO VERIFY "X" DIM ONLY

DIM	GO	NO GO
"X"	.0214	.0261

AMP IDENTIFYING CODE (SEE TABLE)

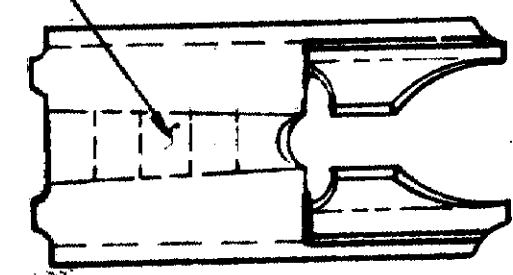

UNLESS OTHERWISE SPECIFIED DIM. ARE IN INCHES. TOLERANCES ON: DECIMALS ±.008 ANGLES ± 5°

CONTRACT NO. #

OR R WELSER 3-23-67

CHK R WELSER 3/27/67

MATERIAL PHOS BRONZE (QQ-P-750)

APPD Ewaler 3-28-67

DESIGN APPD

OTHER APPD

HEAT TREAT

FINISH NOTE 1

STE TE Connectivity

NAME TERMI-POINT CLIP .031X.093 SYSTEM

SIZE B CODE IDENT NO. 00779 NUMBER 330854

SCALE 10:1 WT CALC ACTUAL SHEET 1 OF 1

AMP INFO
LOC PRINTED
AD251P