



Chipsmall Limited consists of a professional team with an average of over 10 year of expertise in the distribution of electronic components. Based in Hongkong, we have already established firm and mutual-benefit business relationships with customers from,Europe,America and south Asia,supplying obsolete and hard-to-find components to meet their specific needs.

With the principle of "Quality Parts,Customers Priority,Honest Operation,and Considerate Service",our business mainly focus on the distribution of electronic components. Line cards we deal with include Microchip,ALPS,ROHM,Xilinx,Pulse,ON,Everlight and Freescale. Main products comprise IC,Modules,Potentiometer,IC Socket,Relay,Connector.Our parts cover such applications as commercial,industrial, and automotives areas.

We are looking forward to setting up business relationship with you and hope to provide you with the best service and solution. Let us make a better world for our industry!



Contact us

Tel: +86-755-8981 8866 Fax: +86-755-8427 6832

Email & Skype: info@chipsmall.com Web: www.chipsmall.com

Address: A1208, Overseas Decoration Building, #122 Zhenhua RD., Futian, Shenzhen, China



THIS DRAWING IS UNPUBLISHED. RELEASED FOR PUBLICATION
 © COPYRIGHT BY TYCO ELECTRONICS CORPORATION. ALL RIGHTS RESERVED.

LOC	DIST	REVISIONS					
		P	LTR	DESCRIPTION	DATE	DWN	APVD
H	-	G4		REV PER ECR-10-000662	18JAN2010	JY	SY
		H		ECR-10-018652	10SEP10	SW	MQW
		J		ECO-11-024491	13DEC11	SY	MQW
		K		ECR-12-010544	6NOV12	SY	AC

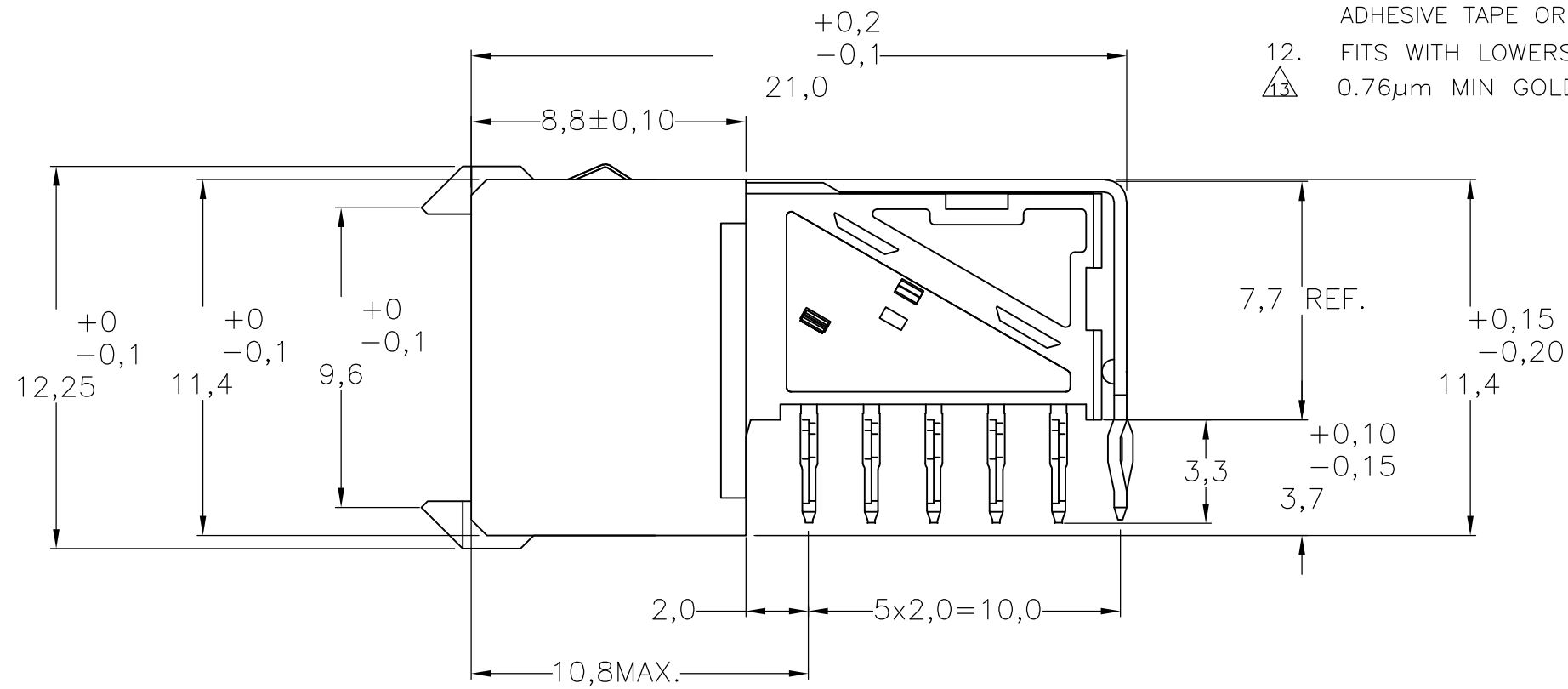
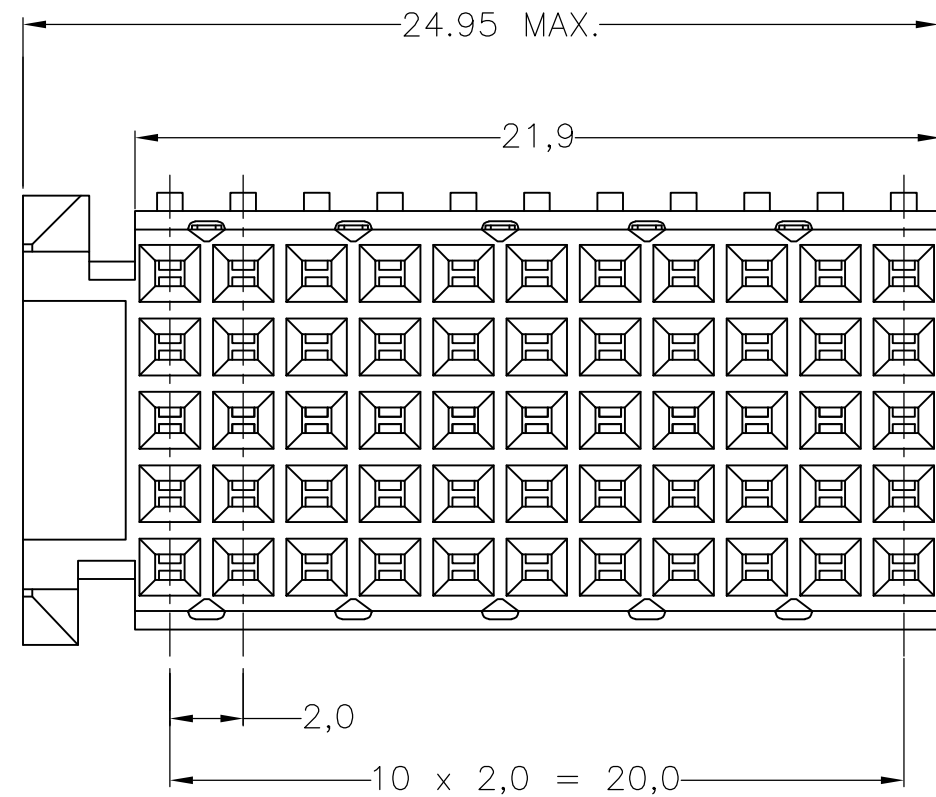
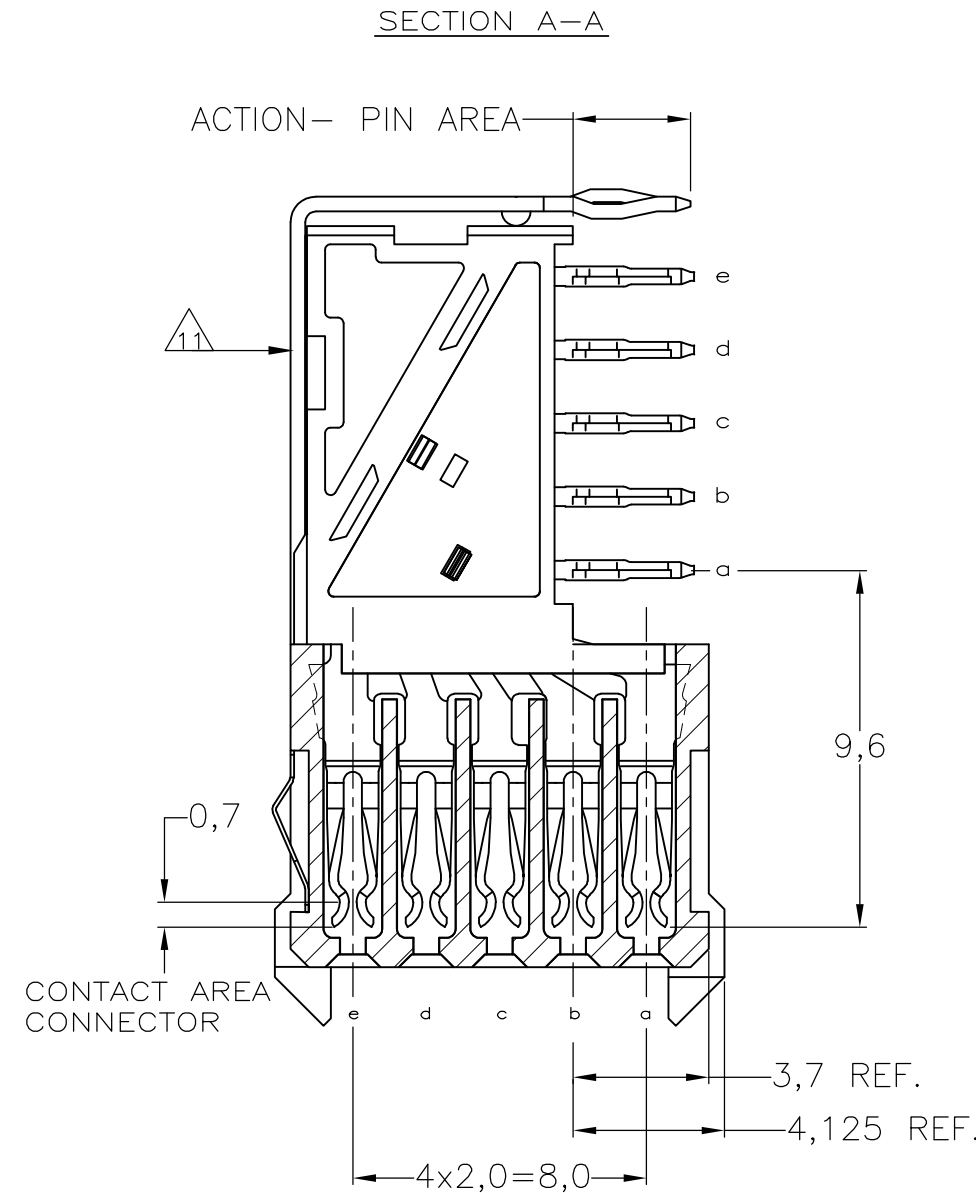
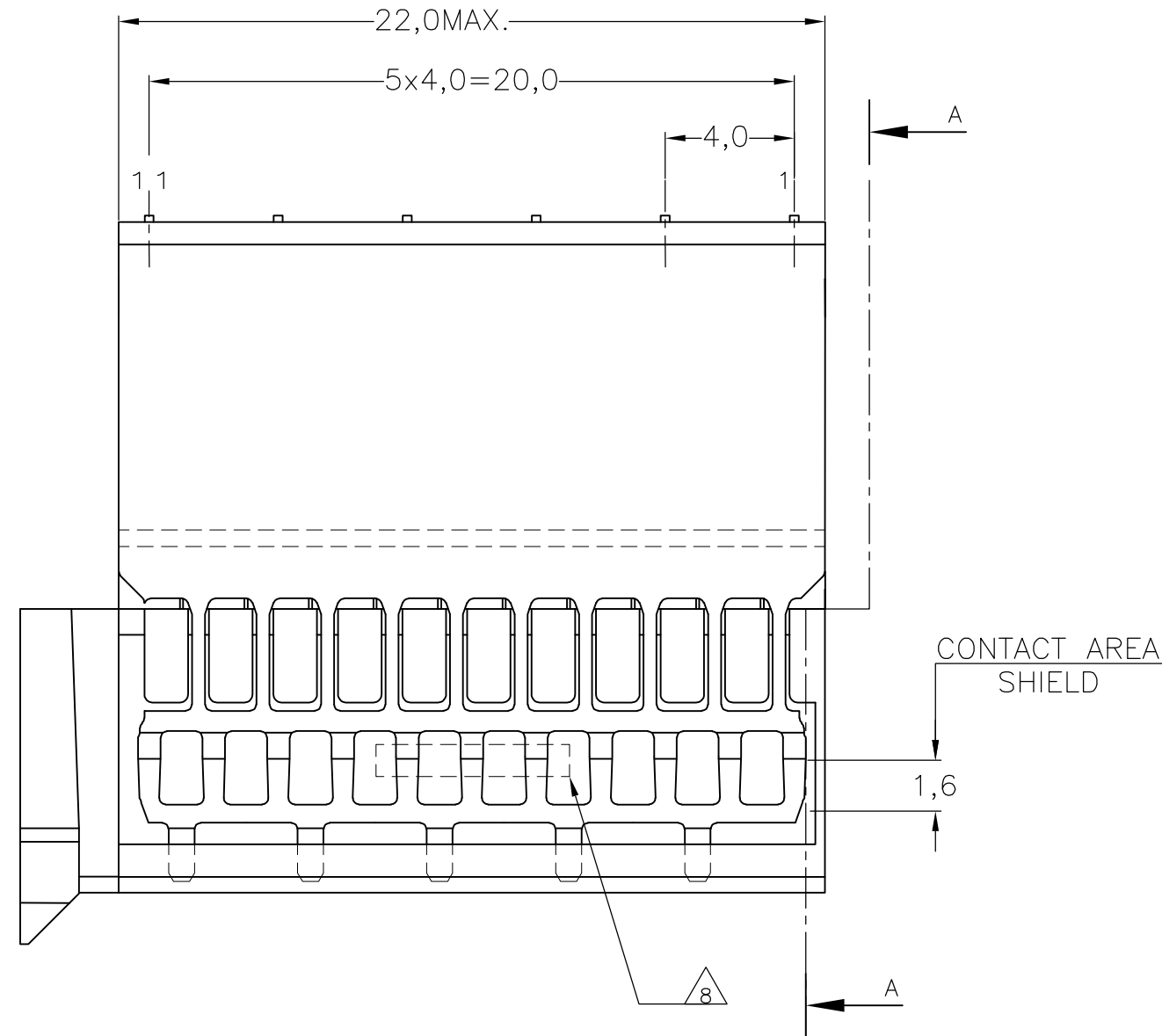

NOTES:

- 1. MATERIAL CONTACTS; PHOSPHORBRONZE
MATERIAL SHIELD ; PHOSPHORBRONZE
MATERIAL HOUSING; GLASSFILLED POLYESTER (GRAY)
- 2. GENERAL PLATING SPECIFICATION: UNDERPLATING
(ENTIRE CONTACT): 1,27µm NICKEL MIN.AND ACTION
PIN: 0,5µm TIN-LEAD MIN.
FOR PLATING OF MATING SURFACES SEE APPLICABLE
SPECIFICATION REFERENCE FOR EACH DASH NUMBER.
- 3. CONFORMS TO ALL TESTING ACCORDING IEC 61076-4-101
PERFORMANCE LEVEL 2.
- 4. CONFORMS TO ALL TESTING ACCORDING IEC 61076-4-101
PERFORMANCE LEVEL 1.
- 5. CONNECTOR TESTED AND QUALIFIED AGAINST TELCORDIA GR-1217-CORE
QUALITY LEVEL III,CENTRAL OFFICE APPLICATIONS.
- 6. CONNECTOR LUBRICATED WITH TELCORDIA GR-1217-CORE
APPROVED LUBRICANT.
- 7. PLATING SHIELD
CONTACT AREA : 0,76µm Au MIN.
ACTION PIN : 0,5µm SnPb MIN.
REMAINDER : Ni
- 8. ASSEMBLY PRINTED WITH P/N AND DATECODE
THE MARKING CAN APPEAR ON THE FRONT SIDE
OR BACK SIDE.
- 9. HOLE PATTERN FOR FEMALE CONNECTOR TYPE C
55 PLATED-THROUGH HOLES AT 2x2mm SQUARE GRID
- 10. ROW "f" 6 PLATED THROUGH HOLES FOR UPPERSHIELD
- 11. SHIELD MOUNTED ON CONNECTOR WITH DOUBLE SIDED
ADHESIVE TAPE OR ADHESIVE
- 12. FITS WITH LOWERSHIELD, BASIC PARTNUMBER : 352112.
- 13. 0.76µm MIN GOLD PLATING AT MATING SURFACES.

COMPONENT SIDE AS SHOWN
 RECOMMENDED PCB-HOLE LAY-OUT
 SCALE 2,5:1

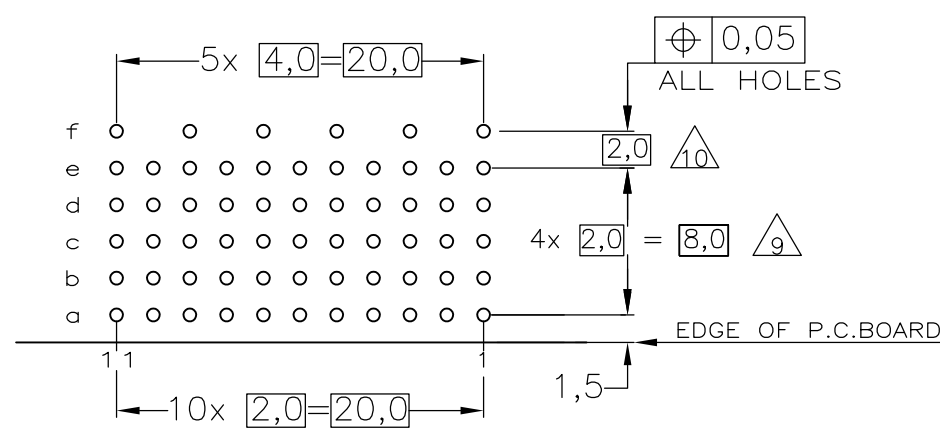

P.C.B. HOLE DIM. ACTION PIN
 FOR DETAILS SEE
 APPLICATION SPECIFICATION

FINISH	MATERIAL	PARTNUMBER
2 3 7 13	1	3-352115-0
2 5 6 7	1	352115-9
2 4 7	1	352115-4
2 3 7	1	352115-1

THIS DRAWING IS A CONTROLLED DOCUMENT.		DWN D. TRUREN	20JAN97	Tyco Electronics Corporation s-HertogenBosch, Netherlands,	
DIMENSIONS: MM		CHK -	APVD -	NAME -	
TOLERANCES UNLESS OTHERWISE SPECIFIED: 0-PLC ± 1-PLC ± 2-PLC ± ±0.2 3-PLC ± 4-PLC ± ANGLES ±		PRODUCT SPEC 108-19082		Z-PACK 2mm HM TYPE C - 11 COLUMNS PRE-SHIELDED RECEPTACLE	
MATERIAL -		FINISH -		SIZE A2	CAGE CODE 00779
		WEIGHT -		DRAWING NO C-352115	RESTRICTED TO -
CUSTOMER DRAWING				SCALE NTS	SHEET 1 OF 1