



Chipsmall Limited consists of a professional team with an average of over 10 year of expertise in the distribution of electronic components. Based in Hongkong, we have already established firm and mutual-benefit business relationships with customers from,Europe,America and south Asia,supplying obsolete and hard-to-find components to meet their specific needs.

With the principle of "Quality Parts,Customers Priority,Honest Operation,and Considerate Service",our business mainly focus on the distribution of electronic components. Line cards we deal with include Microchip,ALPS,ROHM,Xilinx,Pulse,ON,Everlight and Freescale. Main products comprise IC,Modules,Potentiometer,IC Socket,Relay,Connector.Our parts cover such applications as commercial,industrial, and automotives areas.

We are looking forward to setting up business relationship with you and hope to provide you with the best service and solution. Let us make a better world for our industry!



Contact us

Tel: +86-755-8981 8866 Fax: +86-755-8427 6832

Email & Skype: info@chipsmall.com Web: www.chipsmall.com

Address: A1208, Overseas Decoration Building, #122 Zhenhua RD., Futian, Shenzhen, China



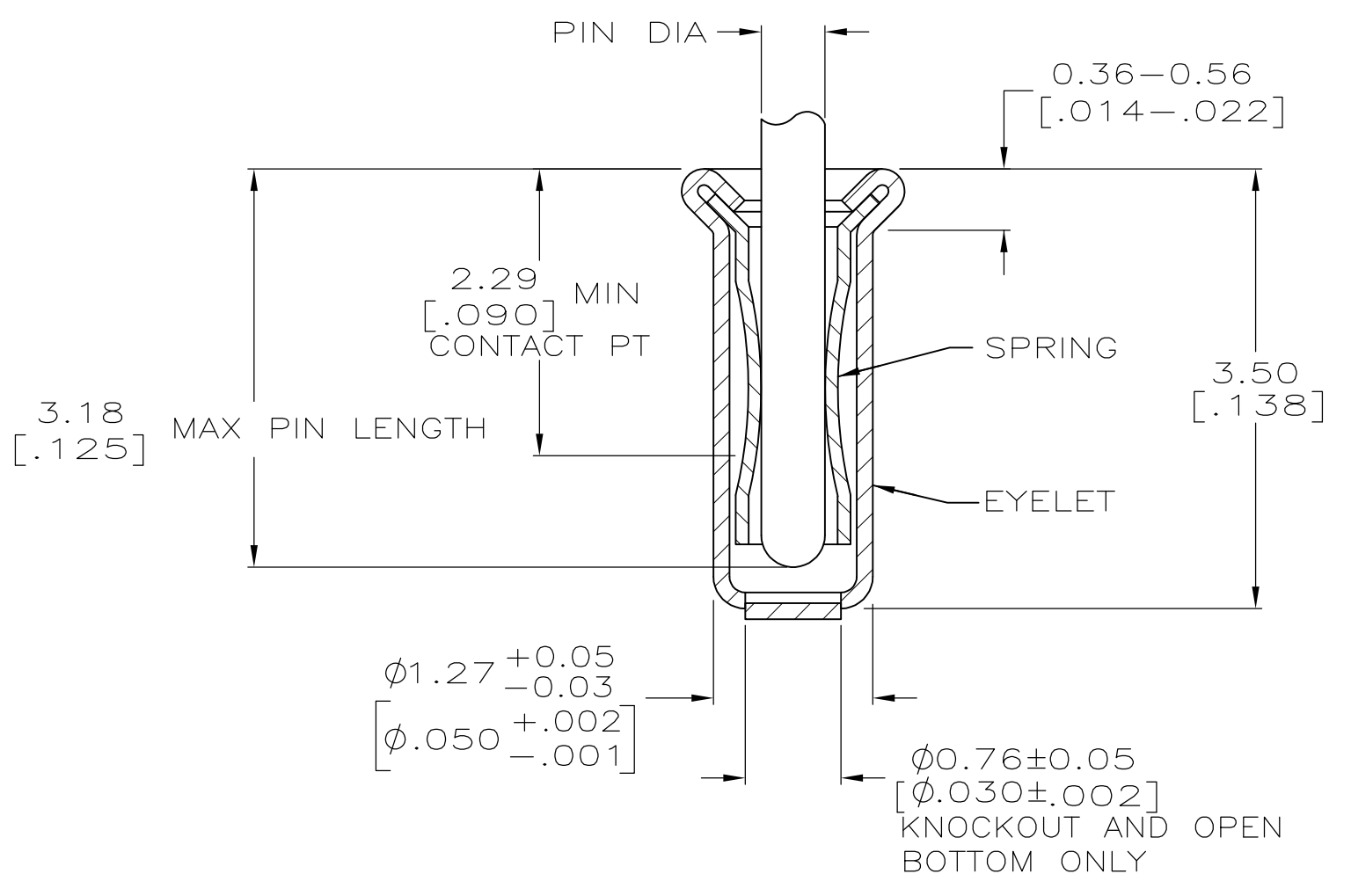
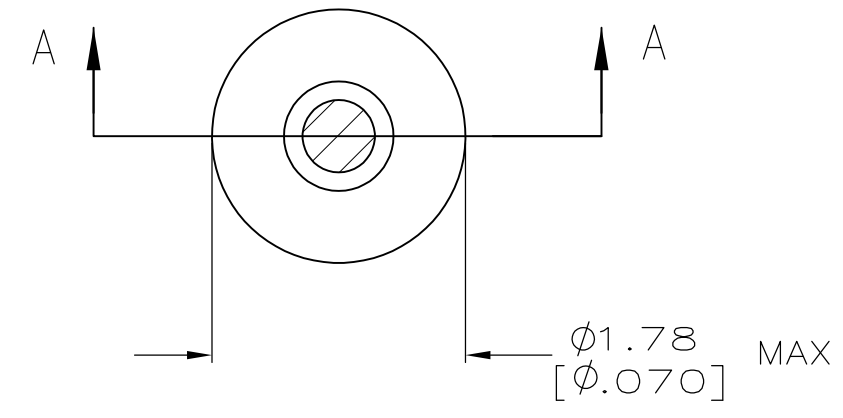

SECTION A-A

- 1. TIN PLATE PER ASTM B 545 .000254 [.000100] MIN THICK.
- 2. GOLD PLATE PER ASTM B 488 0.00076 [.000030] MIN THICK OVER NICKEL PLATE PER QQ-N-290 0.00028 [.000011] MIN THICK ON CONTACT AREA.
- 3. RECOMMENDED HOLE SIZE, PLATED OR UNPLATED:
 MACHINE INSERTION: 1.32±0.05 [.052±.002]
 HAND INSERTION: 1.32 ^{+0.10}/_{-0.00} [.052 ^{+0.04}/_{-.000}]
- 4. APPLICATION TOOL PART NUMBER:
 MACHINE NO. 682127-3
 INSERTION HEAD NO. 682039-2
- 5. TO INSURE PROPER SPRING TENSION DO NOT EXCEED A 0.05 [.002] DIFFERENCE IN PIN DIA WHEN CHANGING TO A SMALLER PIN.
- 6. BOTTOM PLUG KNOCKOUT TOOL PART NUMBER 69729 WITH TIP PART NUMBER 69728.
- 7. MATERIAL:
 SPRING: BERYLLIUM COPPER PER ASTM B 194
 EYELET: COPPER PER ASTM B 152
- 8. OBSOLETE PARTS: OBSOLETE CIS STREAMLINING PER D.RENAUD/D.SINISI

OPEN	0.56-0.64 [.022-.025]	TIN 1	GOLD 2	4-5331272-3
	0.46-0.53 [.018-.021]			3-5331272-9
KNOCKOUT	0.56-0.64 [.022-.025]	TIN 1	TIN 1	3-5331272-5
			GOLD 2	2-5331272-7
CLOSED	0.46-0.53 [.018-.021]	TIN 1	TIN 1	2-5331272-5
			GOLD 2	2-5331272-3
BOTTOM TYPE	RECOMMENDED PIN DIA 5	EYELET	FINISH	PART NO

8 OBSOLETE

THIS DRAWING IS A CONTROLLED DOCUMENT.

DWN A. FERNANDEZ-DOCK5 20APR2005	CHK J. HAVENER 20APR2005	APVD J. HAVENER 20APR2005	NAME MINIATURE SPRING SOCKET ASSEMBLY SERIES 2	
DIMENSIONS: mm[INCHES]		TOLERANCES UNLESS OTHERWISE SPECIFIED:		PRODUCT SPEC 108-14008
0 PLC ± -		1 PLC ± -		APPLICATION SPEC 114-13152
2 PLC ± -		3 PLC ± 0.20 [.008]		SIZE A2
4 PLC ± -		ANGLES ± -		CAGE CODE 00779
MATERIAL 7		FINISH SEE TABLE		DRAWING NO 5331272
WEIGHT -		CUSTOMER DRAWING		RESTRICTED TO -
SCALE 20:1		SHEET 1 of 1		REV P