



Chipsmall Limited consists of a professional team with an average of over 10 year of expertise in the distribution of electronic components. Based in Hongkong, we have already established firm and mutual-benefit business relationships with customers from,Europe,America and south Asia,supplying obsolete and hard-to-find components to meet their specific needs.

With the principle of "Quality Parts,Customers Priority,Honest Operation,and Considerate Service",our business mainly focus on the distribution of electronic components. Line cards we deal with include Microchip,ALPS,ROHM,Xilinx,Pulse,ON,Everlight and Freescale. Main products comprise IC,Modules,Potentiometer,IC Socket,Relay,Connector.Our parts cover such applications as commercial,industrial, and automotives areas.

We are looking forward to setting up business relationship with you and hope to provide you with the best service and solution. Let us make a better world for our industry!



Contact us

Tel: +86-755-8981 8866 Fax: +86-755-8427 6832

Email & Skype: info@chipsmall.com Web: www.chipsmall.com

Address: A1208, Overseas Decoration Building, #122 Zhenhua RD., Futian, Shenzhen, China



THIS DRAWING IS UNPUBLISHED. RELEASED FOR PUBLICATION
 © COPYRIGHT - By - ALL RIGHTS RESERVED.

LOC		DIST		REVISIONS			
P	LTR	DESCRIPTION	DATE	DWN	APVD		
E		REVISED PER ECR-12-008341	07MAY2012	SY	MQW		

- NOTES:
- ⚠ MATERIAL CONTACTS; PHOSPHORBRONZE
 - ⚠ MATERIAL HOUSING; GLASSFILLED POLYESTER (GRAY)
 - ⚠ GENERAL PLATING SPECIFICATION: UNDERPLATING (ENTIRE CONTACT): 1,27µm NICKEL MIN. AND ACTION PIN: 0,5µm TIN MIN.
 - FOR PLATING OF MATING SURFACES SEE APPLICABLE SPECIFICATION REFERENCE FOR EACH DASH NUMBER.
 - ⚠ CONFORMS TO ALL TESTING ACCORDING IEC 61076-4-101 PERFORMANCE LEVEL 2.
 - ⚠ CONFORMS TO ALL TESTING ACCORDING IEC 61076-4-101 PERFORMANCE LEVEL 1.
 - ⚠ CONNECTOR TESTED AND QUALIFIED AGAINST TELCORDIA GR-1217-CORE QUALITY LEVEL III, CENTRAL OFFICE APPLICATIONS.
 - ⚠ CONNECTOR LUBRICATED WITH TELCORDIA GR-1217-CORE APPROVED LUBRICANT.
 - ⚠ PLATING SHIELD:
CONTACT AREA: 0,76µm Au MIN.
ACTION PIN : 0,5µm Sn MIN.
REMAINDER : Ni
 - ⚠ ASSEMBLY PRINTED WITH P/N AND DATECODE
 - ⚠ THE MARKING CAN APPEAR ON THE FRONT SIDE OR BACK SIDE.
 - ⚠ HOLE PATTERN FOR FEMALE CONNECTOR TYPE B-22 COLUMNS
110 PLATED-THROUGH HOLES AT 2x2mm SQUARE GRID
 - ⚠ ROW "f" 11 PLATED THROUGH HOLES FOR UPPERSHIELD
 - ⚠ SHIELD MOUNTED ON CONNECTOR WITH DOUBLE SIDED ADHESIVE TAPE OR ADHESIVE
 - 12 BASIC P.N. LOWERSHIELD : 5352468.
 - ⚠ OBSOLETE PARTS: OBSOLETE CIS STREAMLINING PER D.RENAUD/D.SINISI
 - ⚠ 0.76µm MIN GOLD PLATING AT MATING SURFACE

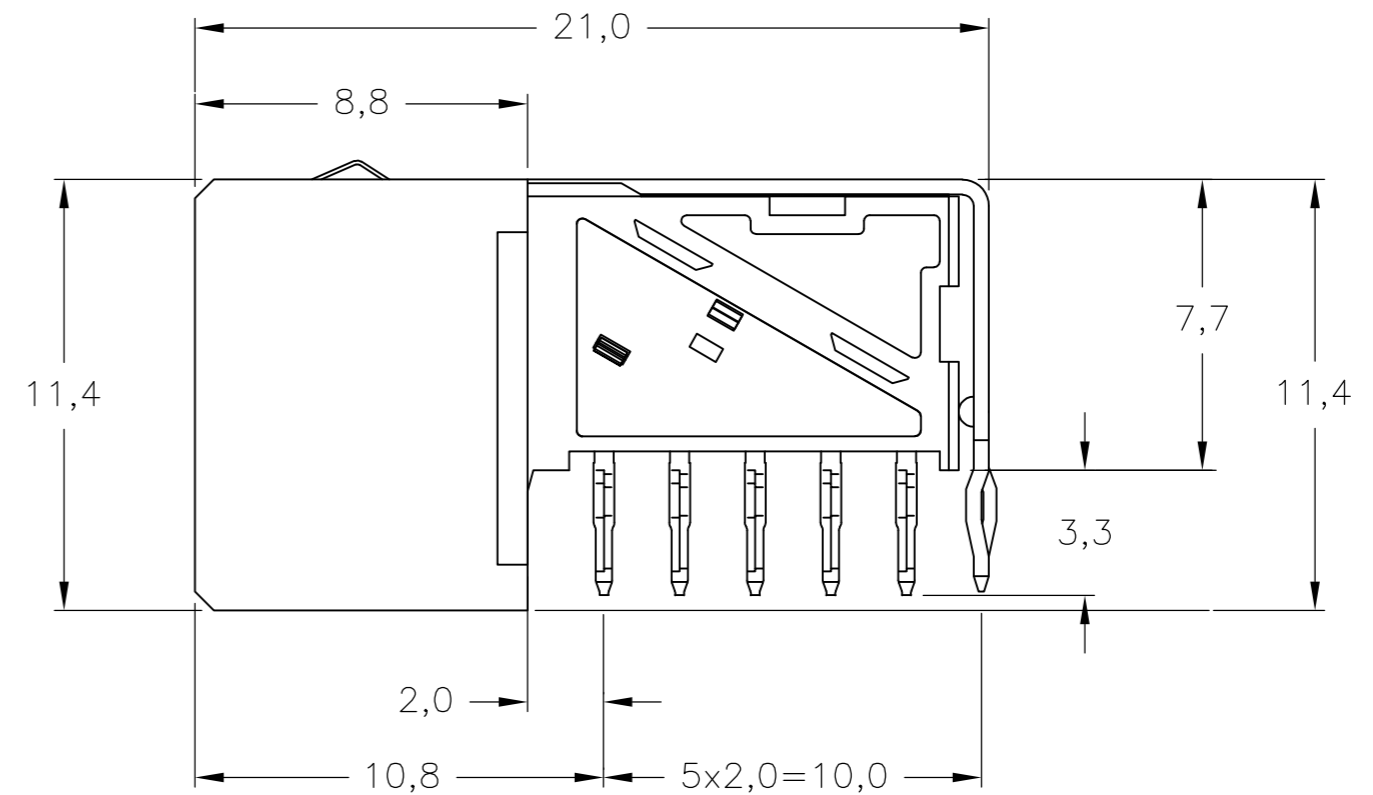
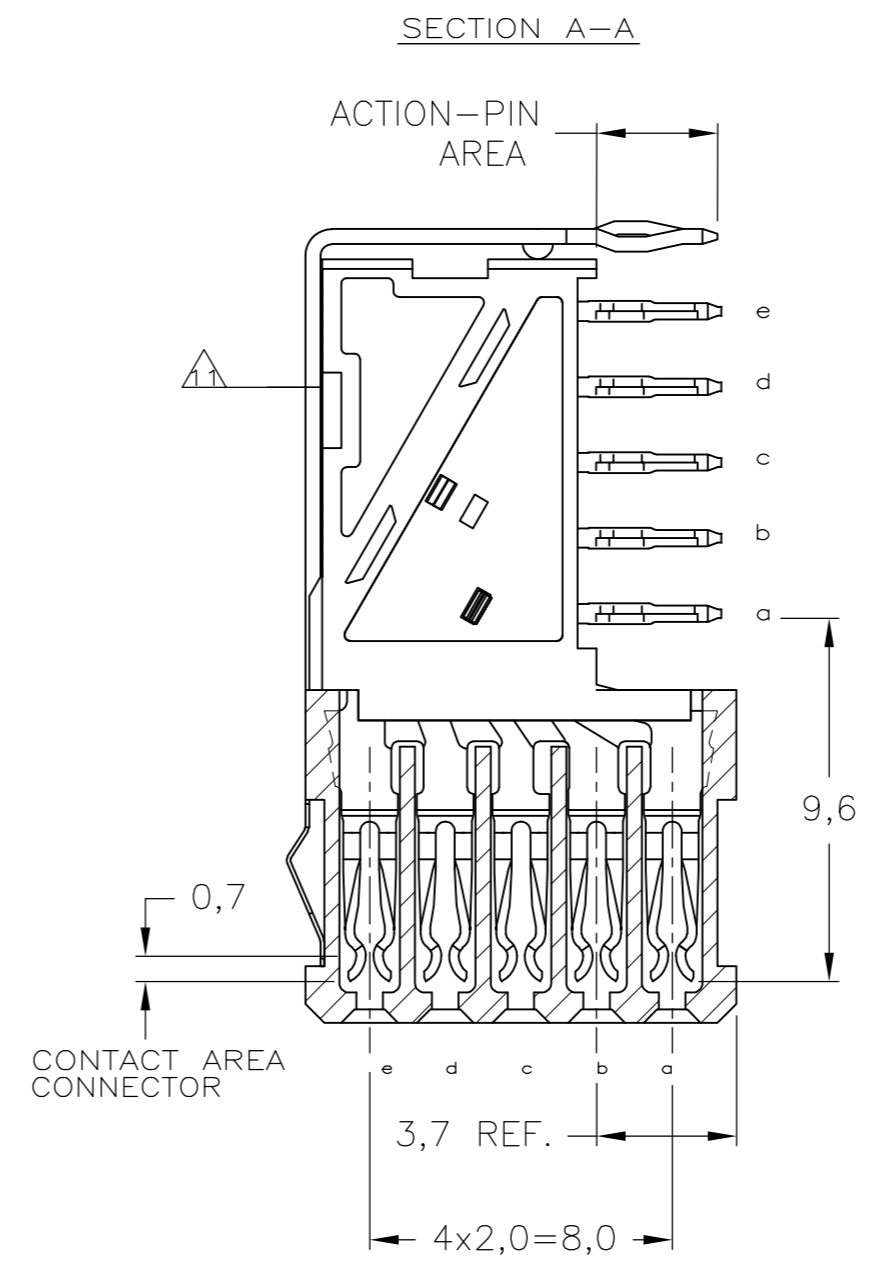
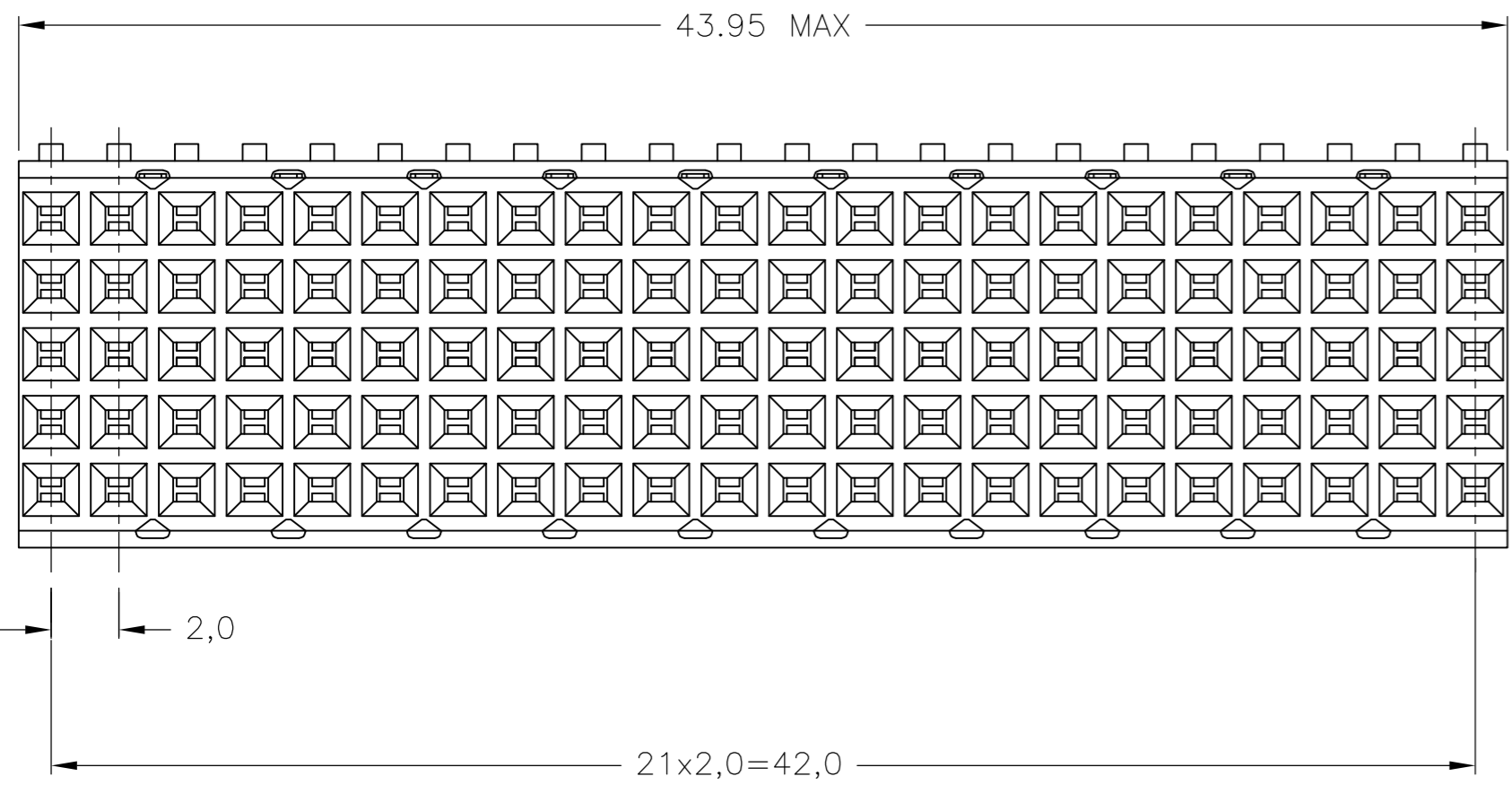
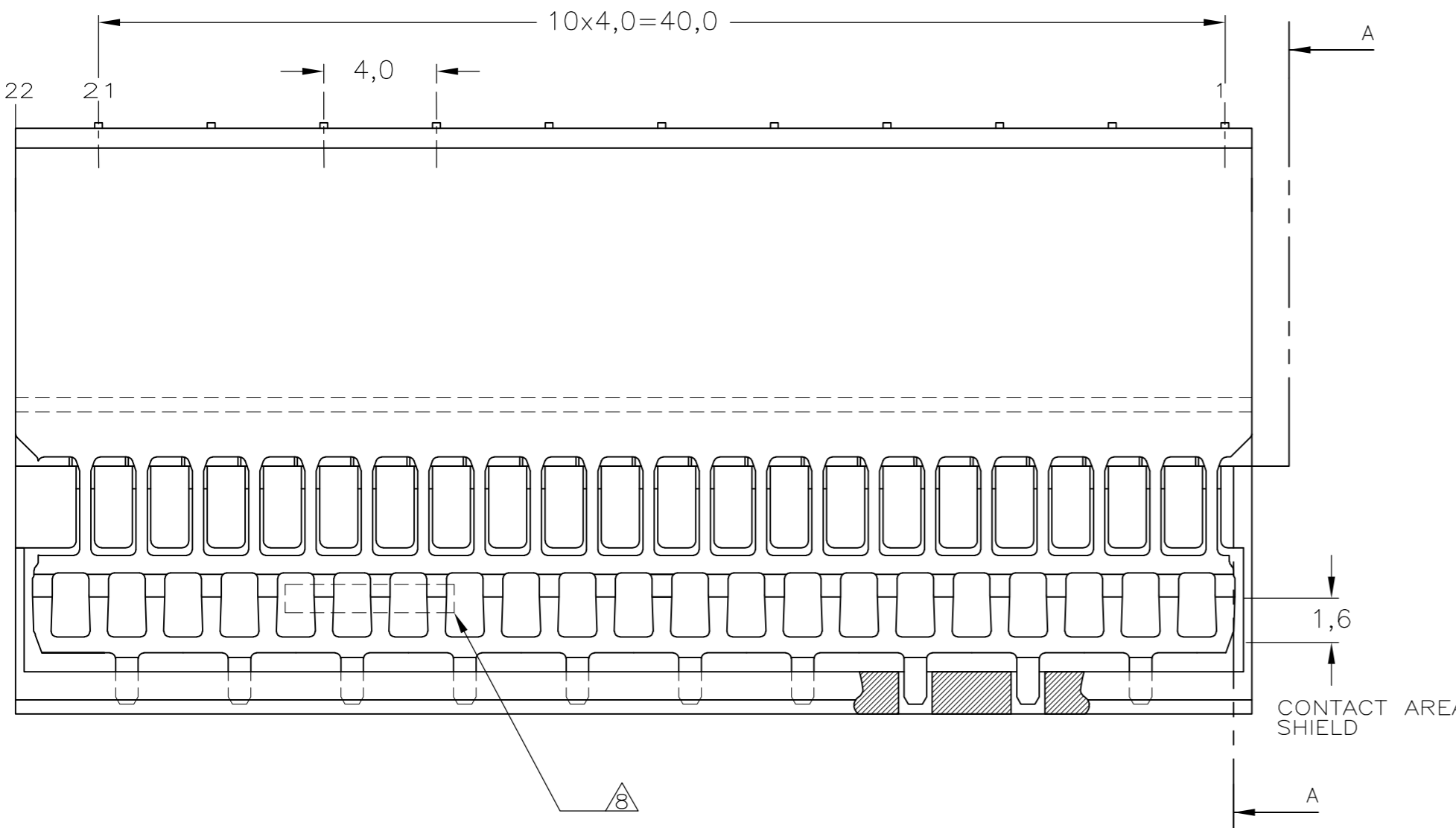

COMPONENT SIDE AS SHOWN
 RECOMMENDED PCB-HOLE LAY-OUT
 SCALE 2,5:1

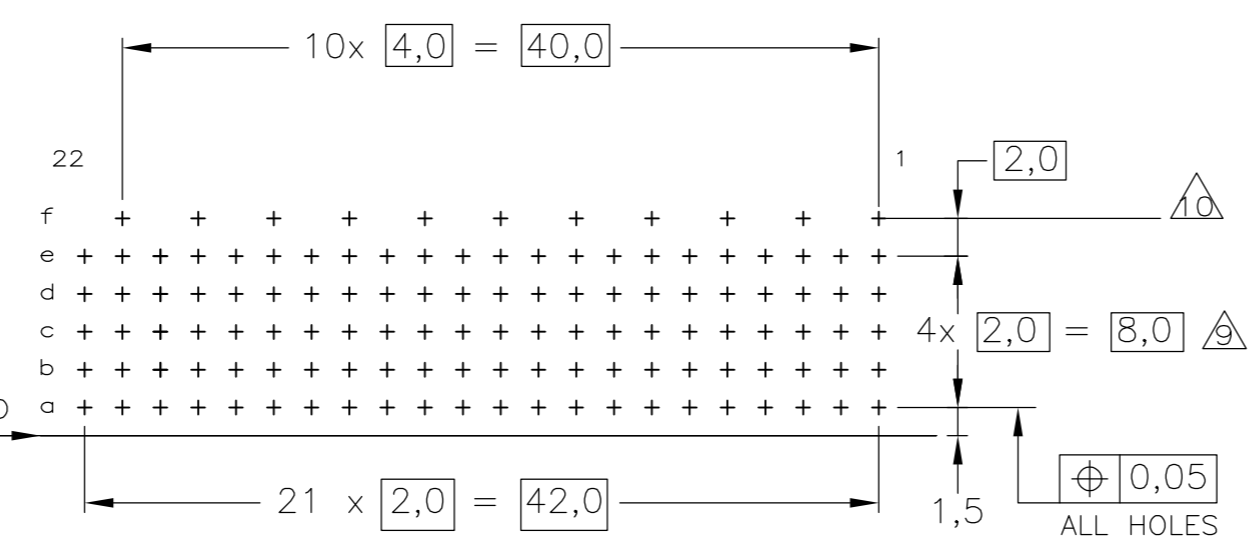

P.C.B. HOLE DIM. ACTION PIN
 FOR DETAILS SEE
 APPLICATION SPECIFICATION

FINISH	MATERIAL	PART NUMBER
⚠	⚠	3-5352152-0
⚠	⚠	5352152-9
⚠	⚠	5352152-4
⚠	⚠	5352152-1

THIS DRAWING IS A CONTROLLED DOCUMENT.

DIMENSIONS: mm	TOLERANCES UNLESS OTHERWISE SPECIFIED: ±0.2	DWN: K.N.KIRAN 20AUG2004		TE Connectivity			
		CHK: B.MOOIJ 27OCT2004		Z-PACK 2mm HM			
		APVD: B.MOOIJ 27OCT2004		TYPE B - 22 COLUMNS			
		PRODUCT SPEC: 108-19082		PRE-SHIELDED RECEPTACLE			
MATERIAL: -	FINISH: -	APPLICATION SPEC: 114-19029	WEIGHT: -	SIZE: A2	CAGE CODE: 00779	DRAWING NO: C=5352152	RESTRICTED TO: -
CUSTOMER DRAWING			SCALE: 5:1	SHEET: 1 OF 1	REV: E		