



Chipsmall Limited consists of a professional team with an average of over 10 year of expertise in the distribution of electronic components. Based in Hongkong, we have already established firm and mutual-benefit business relationships with customers from,Europe,America and south Asia,supplying obsolete and hard-to-find components to meet their specific needs.

With the principle of “Quality Parts,Customers Priority,Honest Operation,and Considerate Service”,our business mainly focus on the distribution of electronic components. Line cards we deal with include Microchip,ALPS,ROHM,Xilinx,Pulse,ON,Everlight and Freescale. Main products comprise IC,Modules,Potentiometer,IC Socket,Relay,Connector.Our parts cover such applications as commercial,industrial, and automotives areas.

We are looking forward to setting up business relationship with you and hope to provide you with the best service and solution. Let us make a better world for our industry!



Contact us

Tel: +86-755-8981 8866 Fax: +86-755-8427 6832

Email & Skype: info@chipsmall.com Web: www.chipsmall.com

Address: A1208, Overseas Decoration Building, #122 Zhenhua RD., Futian, Shenzhen, China



4

3

2

1

THIS DRAWING IS UNPUBLISHED.

RELEASED FOR PUBLICATION MAR , 1999.

© COPYRIGHT 1999 By -

ALL RIGHTS RESERVED.

REVISIONS

P	LTR	DESCRIPTION	DATE	DWN	APVD
-	-	SEE SHEET 1	-	-	-

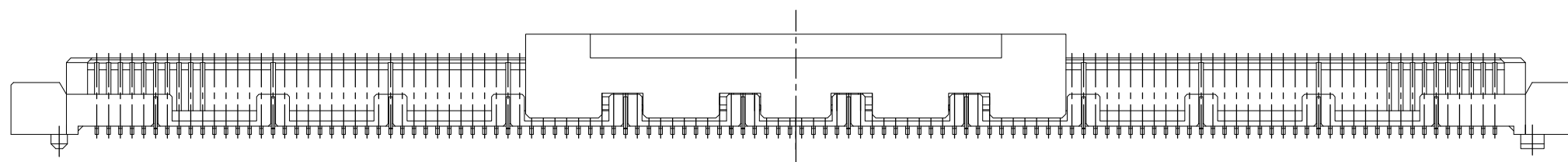
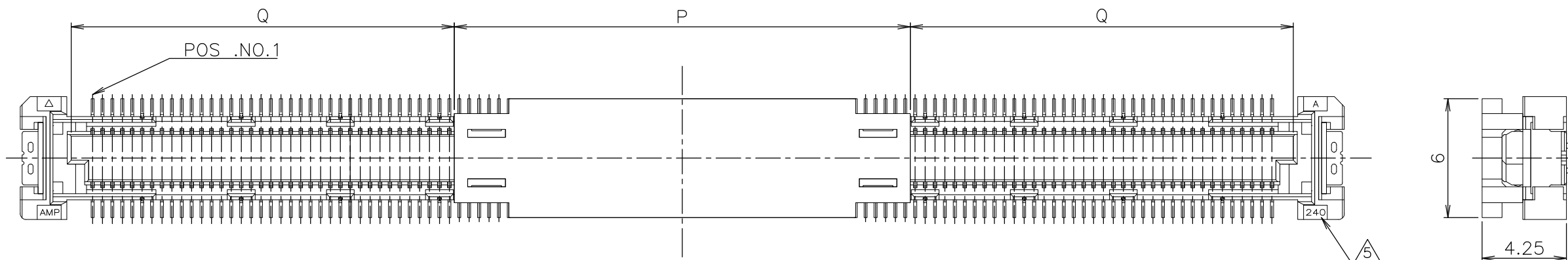

19.55	23	240
17.05	↑	220
14.55		200
12.05		180
10.8		170
9.55		160
8.3		150
7.05		140
4.55		120
2.05	↓	100
0.8	23	90
4.4	13.3	80
4.4	10.8	70
1.9	13.3	60
1.9	10.8	50
1.75	13.3	40
1.75	10.8	30
Q	P	POS.

THIS DRAWING IS A CONTROLLED DOCUMENT.		DWN	STE TE Connectivity		
DIMENSIONS: MM		CHK			
TOLERANCES UNLESS OTHERWISE SPECIFIED:		APVD	NAME		
0 PLC ± -		PRODUCT SPEC	HARD TRAY ASSY		
1 PLC ± -		APPLICATION SPEC	FH 0.5BTB CONNECTOR		
2 PLC ± -		WEIGHT	SIZE	CAGE CODE	DRAWING NO
3 PLC ± -		CUSTOMER DRAWING	A3	00779	C-5353606
4 PLC ± -			SCALE	SHEET	REV
ANGLES ± -			4:1	2 OF 5	B
FINISH					

THIS DRAWING IS UNPUBLISHED. RELEASED FOR PUBLICATION MAR , 1999.
 © COPYRIGHT 1999 By - ALL RIGHTS RESERVED.

REVISIONS					
P	LTR	DESCRIPTION	DATE	DWN	APVD
-	-	SEE SHEET 1	-	-	-

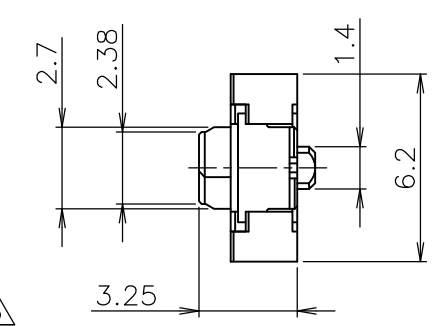
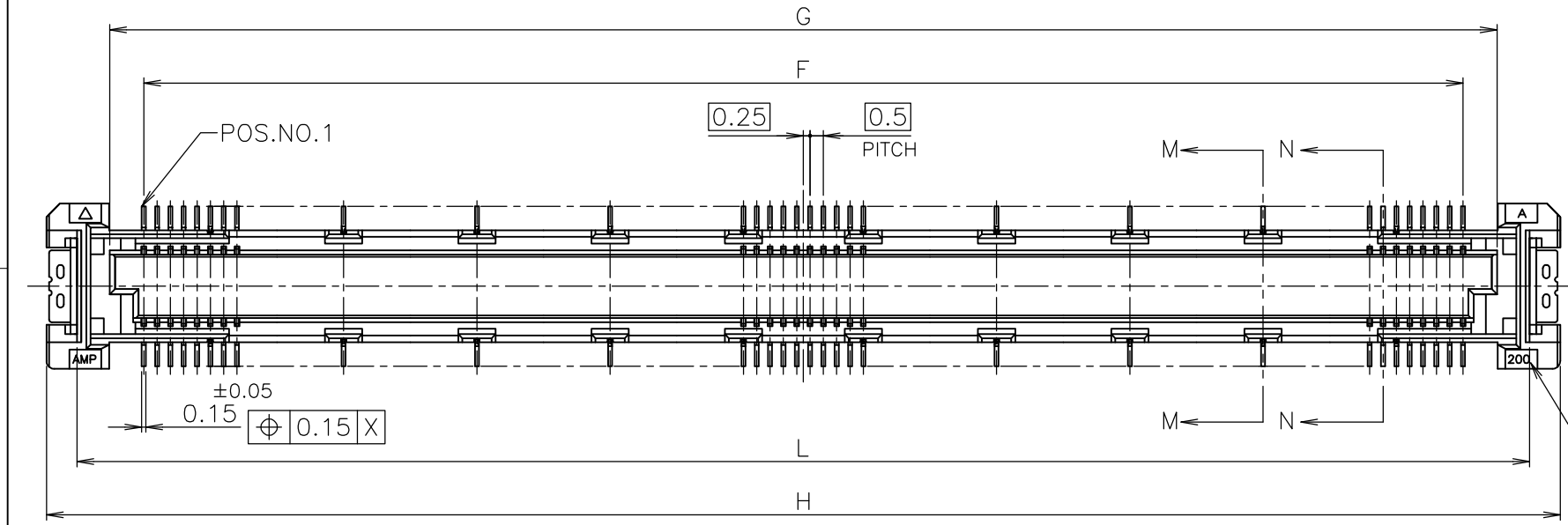

- NOTES**
- ① MATERIAL ; HOUSING : HIGH TEMP THERMO PLASTIC UL94V-0
CONTACT : COPPER ALLOY
 - ② FINISH ; MEETS THE PERFORMANCE REQUIREMENTS OF PRODUCT SPECIFICATION 108-5560
SOLDER PEG : TIN OVER Ni
 - ③ THIS POSITION IS GROUND CIRCUIT.
 - ④ THIS PRODUCT WAS COATED BY ANTI-FLUX-PENETRATION AGENT.
 - ⑤ NO. OF CIRCUIT (DEPEND ON CONNECTOR POS).

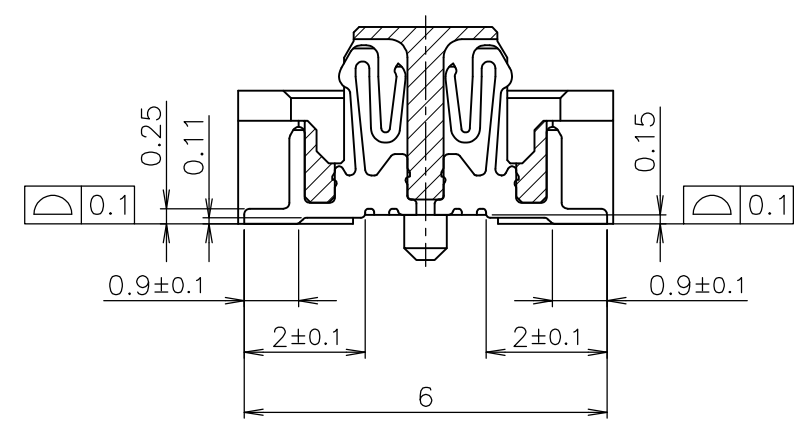
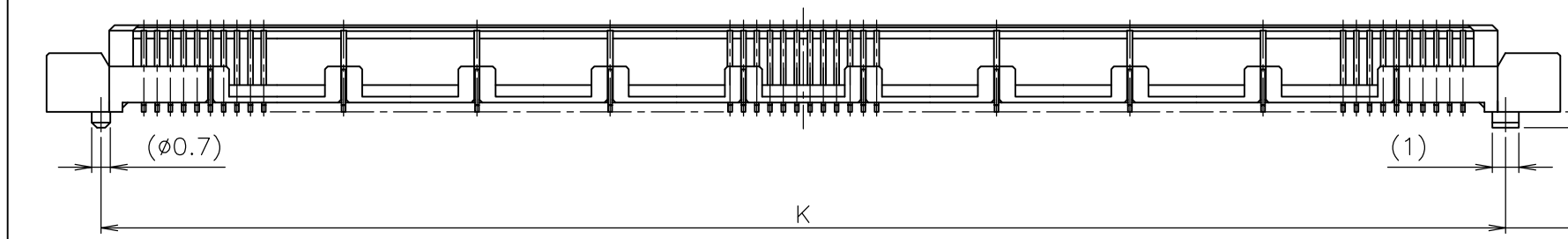

SECT. M-M
(GRAND POSITION)
(SCALE 8:1)

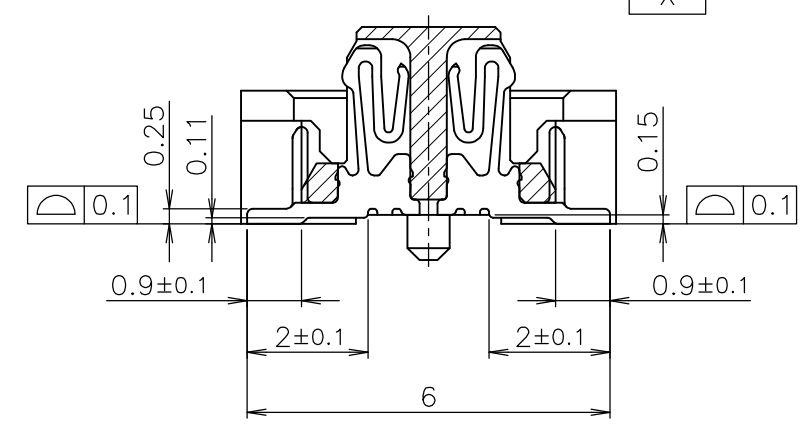

SECT. N-N
(SIGNAL POSITION)
(SCALE 8:1)

64.5	62.7	66.8	62.1	59.5	240
59.5	57.7	61.8	57.1	54.5	220
54.5	52.7	56.8	52.1	49.5	200
49.5	47.7	51.8	47.1	44.5	180
47	45.2	49.3	44.6	42	170
44.5	42.7	46.8	42.1	39.5	160
42	40.2	44.3	39.6	37	150
39.5	37.7	41.8	37.1	34.5	140
34.5	32.7	36.8	32.1	29.5	120
29.5	27.7	31.8	27.1	24.5	100
27	25.2	29.3	24.6	22	90
24.5	22.7	26.8	22.1	19.5	80
22	20.2	24.3	19.6	17	70
19.5	17.7	21.8	17.1	14.5	60
17	15.2	19.3	14.6	12	50
14.5	12.7	16.8	12.1	9.5	40
12	10.2	14.3	9.6	7	30
L	K	H	G	F	POS.

THIS DRAWING IS A CONTROLLED DOCUMENT.		DWN	TE Connectivity NAME HARD TRAY ASSY FH 0.5BTB CONNECTOR REC 4H WITH G-CONT. AND CAP					
DIMENSIONS: MM		CHK				SIZE	CAGE CODE	DRAWING NO
TOLERANCES UNLESS OTHERWISE SPECIFIED:		APVD				A3	00779	C-5353606
0 PLC ± - 1 PLC ± - 2 PLC ± - 3 PLC ± - 4 PLC ± - ANGLES ± - MATERIAL FINISH ± -		PRODUCT SPEC				RESTRICTED TO		
MATERIAL		APPLICATION SPEC	CUSTOMER DRAWING					
		WEIGHT	SCALE 4:1					
			SHEET 3 OF 5					
			REV B					

THIS DRAWING IS UNPUBLISHED.
 © COPYRIGHT 1999 By -
 ALL RIGHTS RESERVED.

RELEASED FOR PUBLICATION
 MAR , 1999.

REVISIONS

P	LTR	DESCRIPTION	DATE	DWN	APVD
-	-	SEE SHEET 1	-	-	-

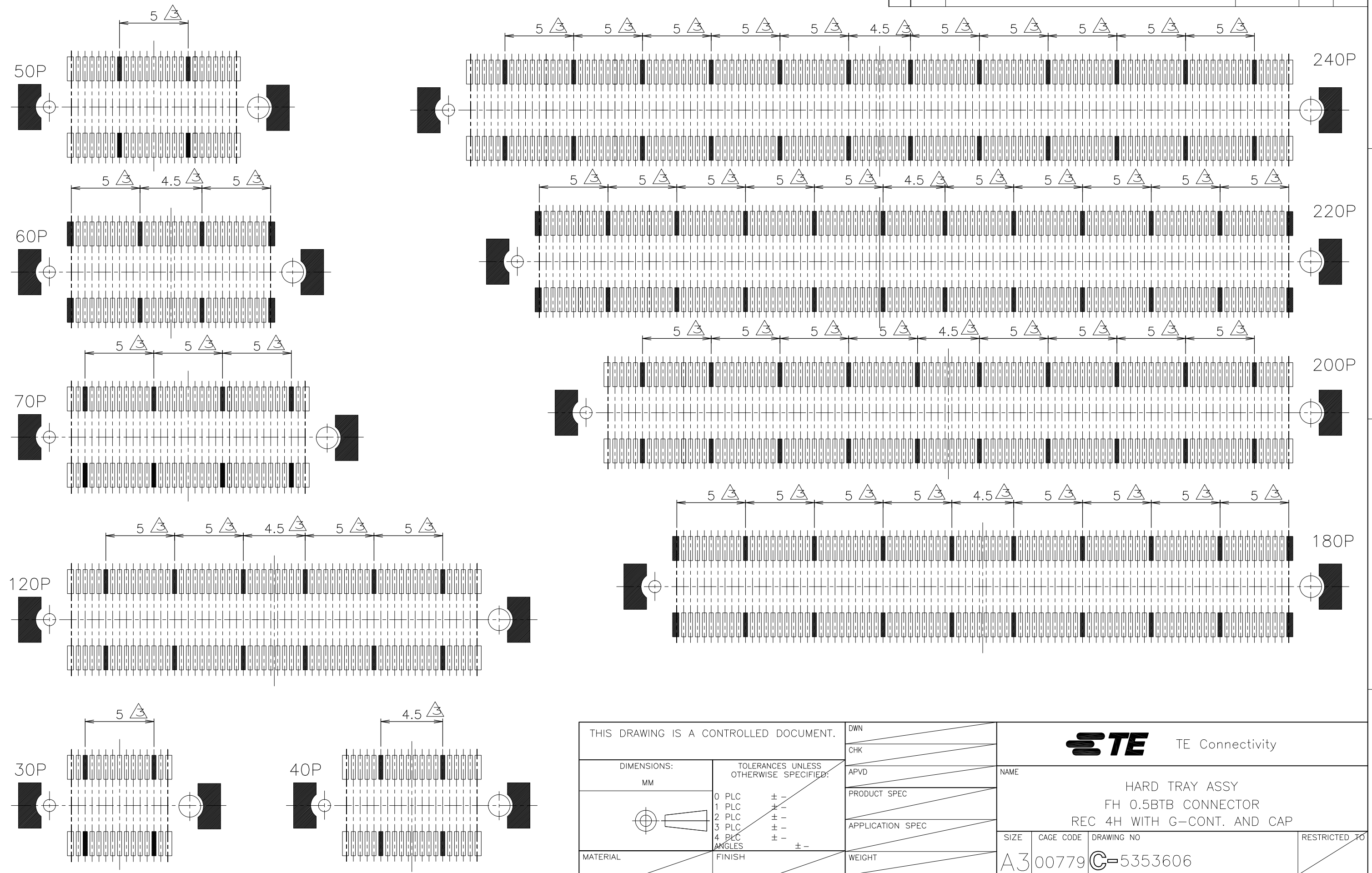

THIS DRAWING IS A CONTROLLED DOCUMENT.		DWN		TE Connectivity NAME HARD TRAY ASSY FH 0.5BTB CONNECTOR REC 4H WITH G-CONT. AND CAP	
DIMENSIONS: MM		CHK			
TOLERANCES UNLESS OTHERWISE SPECIFIED:		APVD			
0 PLC ± - 1 PLC ± - 2 PLC ± - 3 PLC ± - 4 PLC ± - ANGLES ± - FINISH ± -		PRODUCT SPEC			
MATERIAL		WEIGHT		APPLICATION SPEC	
		CUSTOMER DRAWING		SIZE	RESTRICTED TO
				A3	
				CAGE CODE	
				G-5353606	
				DRAWING NO	
				SCALE	
				4:1	
				SHEET	
				5 OF 5	
				REV	
				B	