



Chipsmall Limited consists of a professional team with an average of over 10 year of expertise in the distribution of electronic components. Based in Hongkong, we have already established firm and mutual-benefit business relationships with customers from,Europe,America and south Asia,supplying obsolete and hard-to-find components to meet their specific needs.

With the principle of "Quality Parts,Customers Priority,Honest Operation,and Considerate Service",our business mainly focus on the distribution of electronic components. Line cards we deal with include Microchip,ALPS,ROHM,Xilinx,Pulse,ON,Everlight and Freescale. Main products comprise IC,Modules,Potentiometer,IC Socket,Relay,Connector.Our parts cover such applications as commercial,industrial, and automotives areas.

We are looking forward to setting up business relationship with you and hope to provide you with the best service and solution. Let us make a better world for our industry!



Contact us

Tel: +86-755-8981 8866 Fax: +86-755-8427 6832

Email & Skype: info@chipsmall.com Web: www.chipsmall.com

Address: A1208, Overseas Decoration Building, #122 Zhenhua RD., Futian, Shenzhen, China



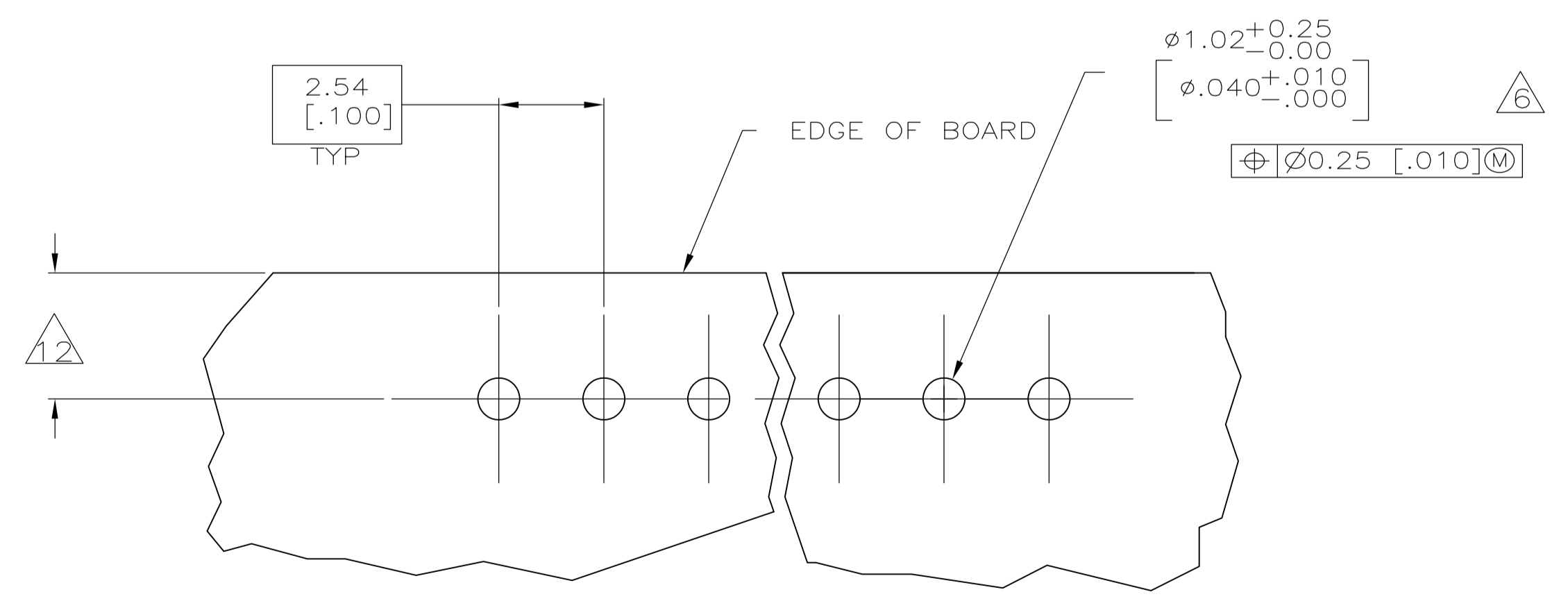
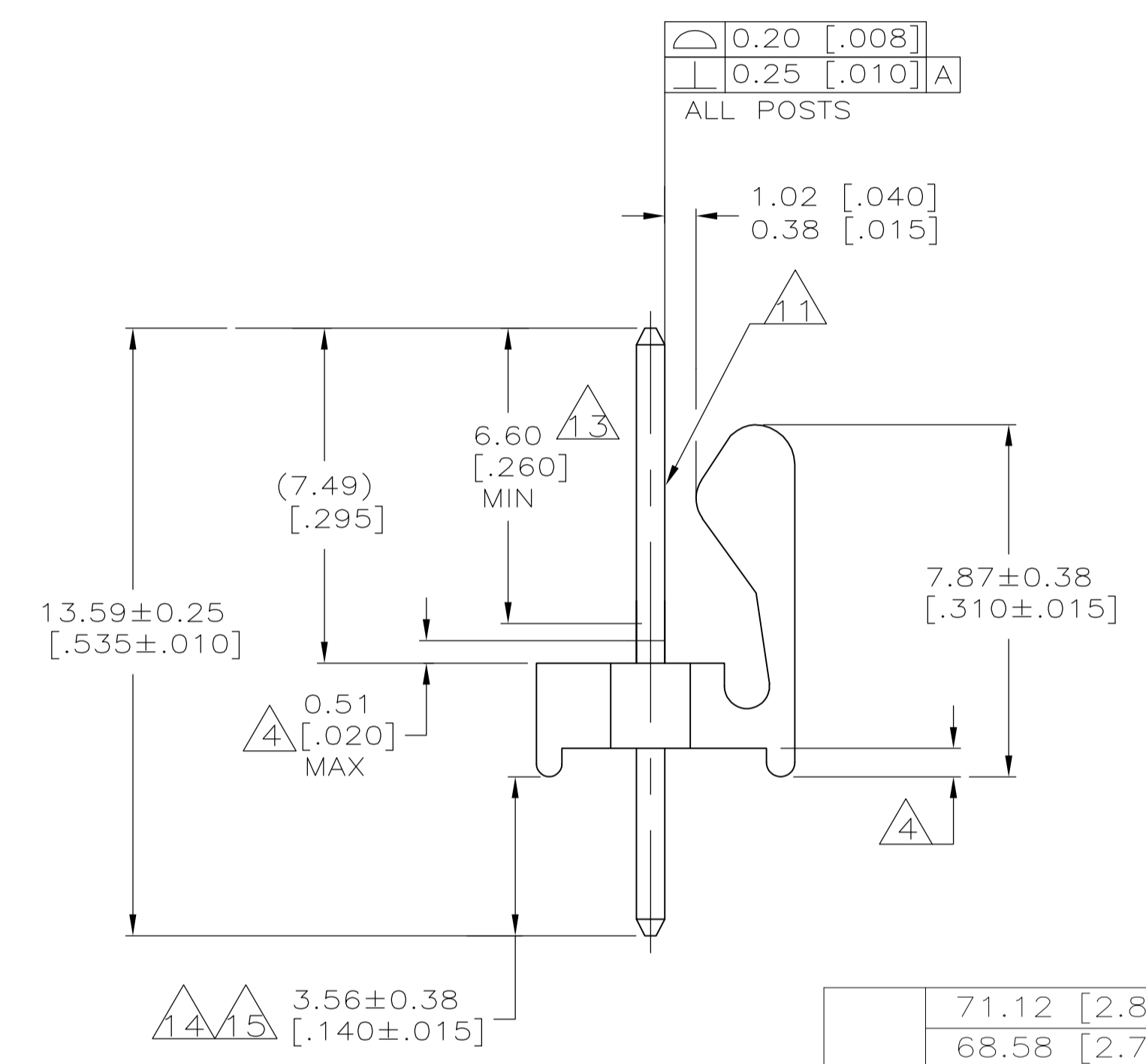
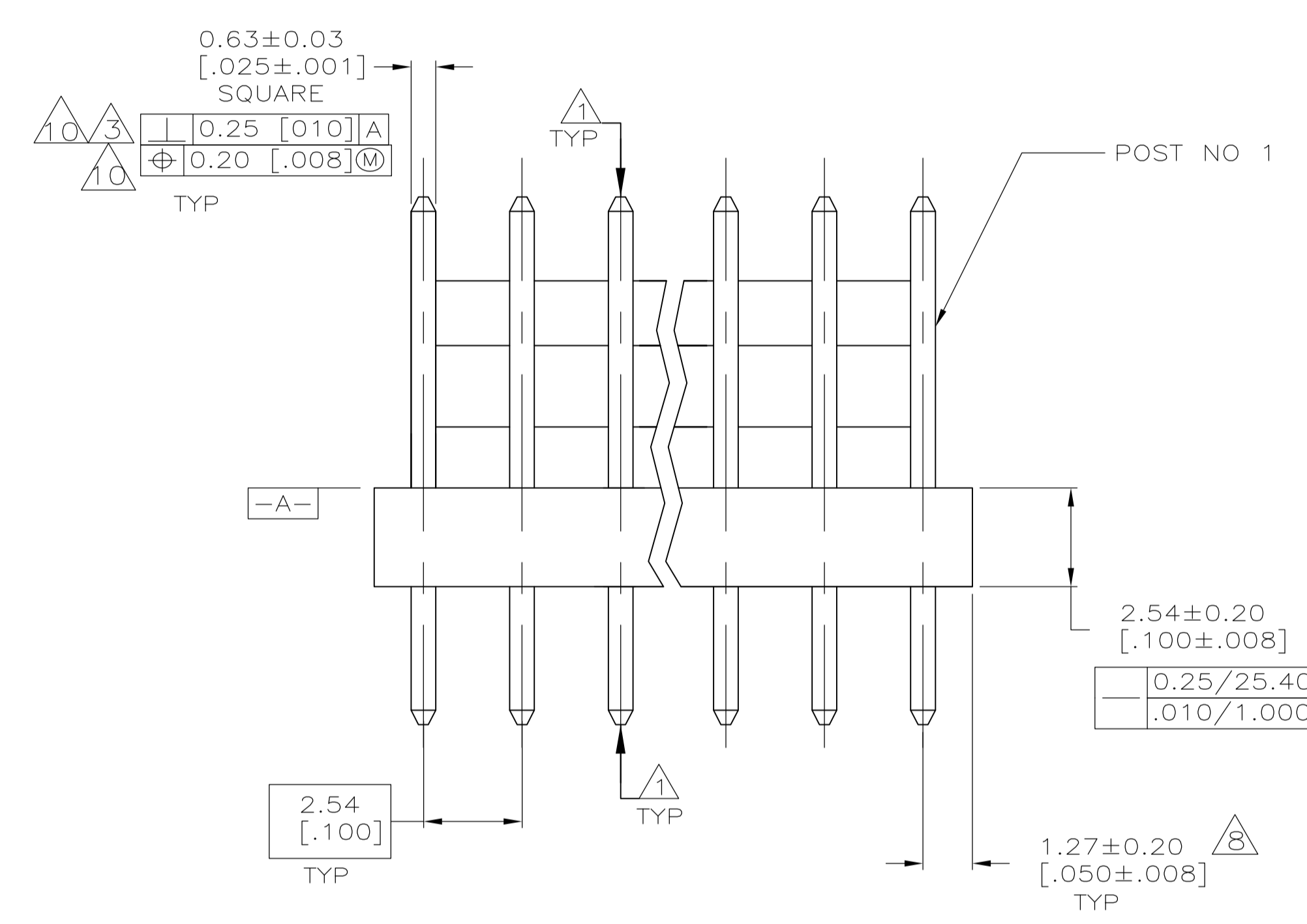
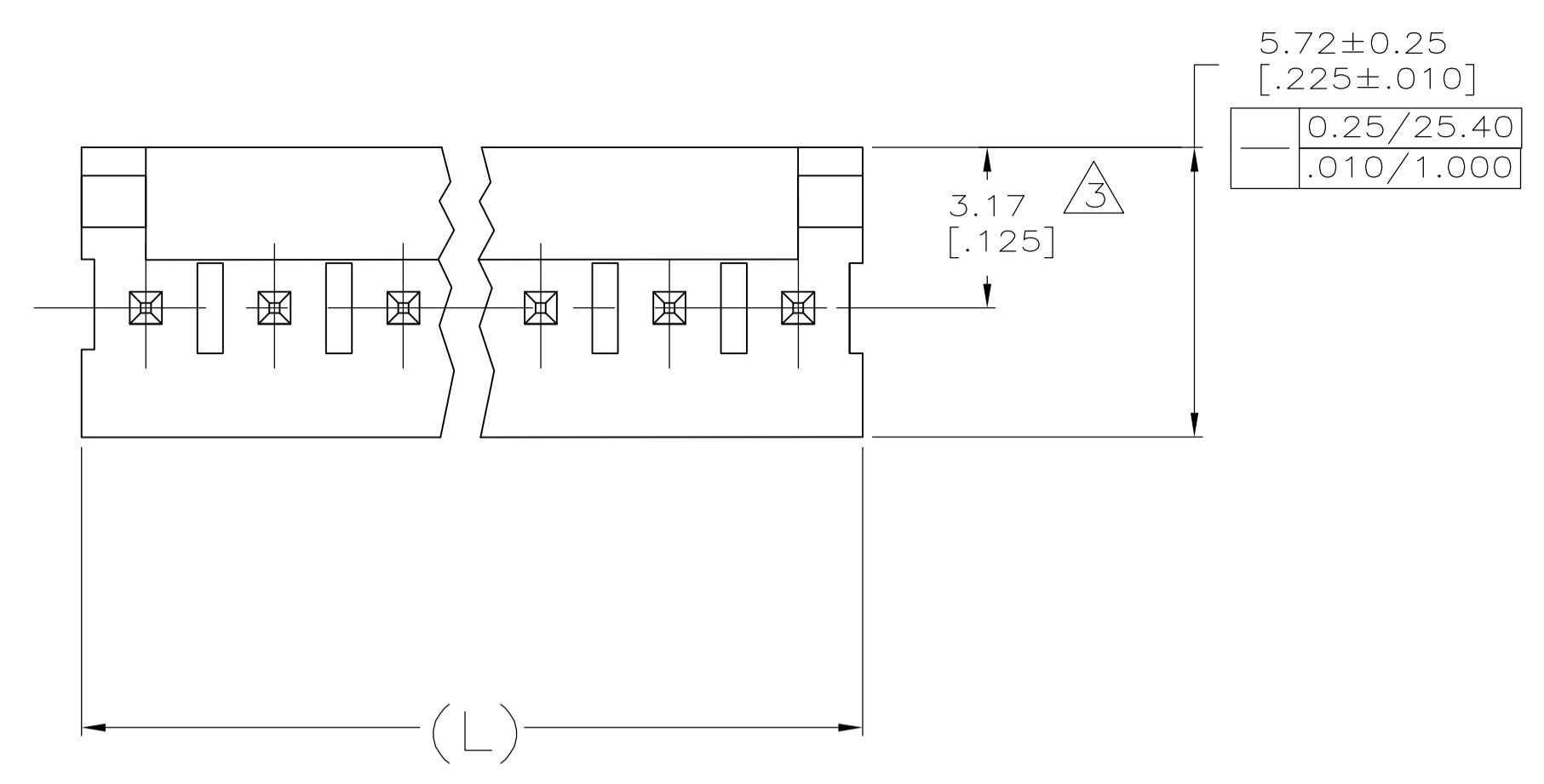

RECOMMENDED MOUNTING HOLE PATTERN FOR 1.60 [.063] THICK P.C. BOARD

- 1 POST TO WITHSTAND 13 NEWTONS (3 LBS) MINIMUM AXIAL FORCE IN BOTH DIRECTIONS SHOWN WITHOUT DISLODGING.
- 2 TOLERANCES APPLY TO SOLDER SIDE OF BOARD.
- 3 MEASURED \square ATA-
- 4 PLASTIC FLASH PERMITTED IN THIS AREA.
- 5 PARTS COMPLY WITH AMP SOLDERABILITY SPEC. NO. 109-11-2.
- 6 ONE HOLE MAY BE UNDERSIZED 0.81-0.89 [.032-.035] DIA. FOR ASSEMBLY RETENTION DURING WAVE SOLDERING.
- 7 MATERIAL: HEADER-THERMOPLASTIC POLYESTER
94V-0 (NATURAL)
POST-COPPER ALLOY
FINISH-USE PLATING NOTES 13 & 14 FOR -2 THRU -28
AND NOTES 13 & 15 FOR -32 THRU -58
- 8 COORDINATE DIMENSION APPLIES FROM CENTER OF ACTUAL FEATURE.
- 9 PLASTIC BURRS CAUSED BY CUT-OFF TOOLING ARE PERMITTED WITHIN THE MAXIMUM TOLERANCE ENVELOPE.
- 10 POSTS TO BE MEASURED WHEN STRIP IS HELD FLAT.
- 11 POST MUST WITHSTAND TWO 90° BENDS AGAINST EXTRUSION WITHOUT BREAKING.
- 12 DIMENSION SHOULD BE 3.30 [.130] MIN WHEN MATING WITH A MTA-100 CONNECTOR ASSEMBLY OR A CST-100 CONNECTOR ASSEMBLY.
- 13 PLATING: GOLD PLATE AREA, 0.00038 [.000015] GOLD OR 0.00008 [.000003] MIN GOLD FLASH OVER 0.00030 [.000012] PALLADIUM NICKEL, PER TE CONNECTIVITY'S DISCRETION, ALL SIDES, OVER NICKEL UNDERPLATE, 0.00127 [.000050] MIN, ALL SIDES AND ENTIRE LENGTH OF POST.
- 14 PLATING: BRIGHT TIN/LEAD (93/7) PLATE AREA, 0.00381-0.00889 [.000150-.000350] THICK, ALL FOUR SIDES 3.56 [.140] MINIMUM.
- 15 PLATING: MATTE TIN PLATE AREA, 0.00381-0.00889 [.000150-.000350] THICK, ALL FOUR SIDES 3.56 [.140] MINIMUM.
- 16 OBSOLETE PARTS: OBSOLETE CIS STREAMLINING PER D.RENAUD/D.SINISI

71.12	[2.800]	28	5-641126-8
68.58	[2.700]	27	5-641126-7
66.04	[2.600]	26	5-641126-6
63.50	[2.500]	25	5-641126-5
60.96	[2.400]	24	5-641126-4
58.42	[2.300]	23	5-641126-3
55.88	[2.200]	22	5-641126-2
53.34	[2.100]	21	5-641126-1
50.80	[2.000]	20	5-641126-0
48.26	[1.900]	19	4-641126-9
45.72	[1.800]	18	4-641126-8
43.18	[1.700]	17	4-641126-7
40.64	[1.600]	16	4-641126-6
38.10	[1.500]	15	4-641126-5
35.56	[1.400]	14	4-641126-4
33.02	[1.300]	13	4-641126-3
30.48	[1.200]	12	4-641126-2
27.94	[1.100]	11	4-641126-1
25.40	[1.000]	10	4-641126-0
22.86	[.900]	9	3-641126-9
20.32	[.800]	8	3-641126-8
17.78	[.700]	7	3-641126-7
15.24	[.600]	6	3-641126-6
12.70	[.500]	5	3-641126-5
10.16	[.400]	4	3-641126-4
7.62	[.300]	3	3-641126-3
5.08	[.200]	2	3-641126-2
DIM (L)		NO. OF POSN	ASSEMBLY

71.12	[2.800]	28	2-641126-8	SUPERSEDED BY 5-641126-8
68.58	[2.700]	27	2-641126-7	SUPERSEDED BY 5-641126-7
66.04	[2.600]	26	2-641126-6	SUPERSEDED BY 5-641126-6
63.50	[2.500]	25	2-641126-5	SUPERSEDED BY 5-641126-5
60.96	[2.400]	24	2-641126-4	SUPERSEDED BY 5-641126-4
58.42	[2.300]	23	2-641126-3	SUPERSEDED BY 5-641126-3
55.88	[2.200]	22	2-641126-2	SUPERSEDED BY 5-641126-2
53.34	[2.100]	21	2-641126-1	SUPERSEDED BY 5-641126-1
50.80	[2.000]	20	2-641126-0	
48.26	[1.900]	19	1-641126-9	SUPERSEDED BY 4-641126-9
45.72	[1.800]	18	1-641126-8	
43.18	[1.700]	17	1-641126-7	SUPERSEDED BY 4-641126-7
40.64	[1.600]	16	1-641126-6	
38.10	[1.500]	15	1-641126-5	
35.56	[1.400]	14	1-641126-4	
33.02	[1.300]	13	1-641126-3	SUPERSEDED BY 4-641126-3
30.48	[1.200]	12	1-641126-2	
27.94	[1.100]	11	1-641126-1	
25.40	[1.000]	10	1-641126-0	
22.86	[.900]	9	641126-9	
20.32	[.800]	8	641126-8	
17.78	[.700]	7	641126-7	
15.24	[.600]	6	641126-6	
12.70	[.500]	5	641126-5	
10.16	[.400]	4	641126-4	
7.62	[.300]	3	641126-3	
5.08	[.200]	2	641126-2	
DIM (L)		NO. OF POSN	ASSEMBLY	

METRIC

THIS DRAWING IS A CONTROLLED DOCUMENT.

DIMENSIONS: mm [INCHES]	TOLERANCES UNLESS OTHERWISE SPECIFIED:	DIN S. HOOVER 26-JAN-2005	APVD D. ROSSI 26-JAN-2005	NAME
0 PLC ±	±			MTA-100 HEADER ASSEMBLY, FRICTION LOCK, NOTCHED, .025 SQUARE STRAIGHT POST, .000015 GOLD PLATED
1 PLC ±	±			
2 PLC ±	±			
3 PLC ±	± 0.13 [.005]			
4 PLC ±	±			
ANGLES	±			
MATERIAL	FINISH	APPLICATION SPEC	WEIGHT	SIZE
				CAGE CODE DRAWING NO. RESTRICTED TO
			A1 00779	641126
		CUSTOMER DRAWING	SCALE 8:1	SHEET 1 OF 1 REV Z