



Chipsmall Limited consists of a professional team with an average of over 10 year of expertise in the distribution of electronic components. Based in Hongkong, we have already established firm and mutual-benefit business relationships with customers from,Europe,America and south Asia,supplying obsolete and hard-to-find components to meet their specific needs.

With the principle of "Quality Parts,Customers Priority,Honest Operation,and Considerate Service",our business mainly focus on the distribution of electronic components. Line cards we deal with include Microchip,ALPS,ROHM,Xilinx,Pulse,ON,Everlight and Freescale. Main products comprise IC,Modules,Potentiometer,IC Socket,Relay,Connector.Our parts cover such applications as commercial,industrial, and automotives areas.

We are looking forward to setting up business relationship with you and hope to provide you with the best service and solution. Let us make a better world for our industry!



Contact us

Tel: +86-755-8981 8866 Fax: +86-755-8427 6832

Email & Skype: info@chipsmall.com Web: www.chipsmall.com

Address: A1208, Overseas Decoration Building, #122 Zhenhua RD., Futian, Shenzhen, China



- 1 POST TO WITHSTAND 13 NEWTONS (3LBS.) MINIMUM AXIAL FORCE IN BOTH DIRECTIONS SHOWN WITHOUT DISLODGING.
- 2 TOLERANCES APPLY TO SOLDER SIDE OF BOARD.
- 3 MEASURED AT SURFACE $\overline{-A-}$
- 4 PLASTIC FLASH PERMITTED IN THIS AREA.
- 5 PARTS COMPLY WITH AMP SOLDERABILITY SPEC. NO. 109-11-2.
- 6 ONE HOLE MAY BE UNDERSIZED 1.65-1.52 [.065-.060] DIA. FOR ASSEMBLY RETENTION DURING WAVE SOLDERING.
- 7 MATERIAL: HEADER-THERMOPLASTIC POLYESTER
GLASS-FILLED 94V-0 (NATURAL)
POST-COPPER ALLOY (SEE NOTES 13 & 14 FOR PLATING)
- 8 COORDINATE DIMENSION APPLIES FROM CENTER OF ACTUAL FEATURE.
- 9 PLASTIC BURRS CAUSED BY CUT-OFF TOOLING ARE PERMITTED WITHIN THE MAXIMUM TOLERANCE ENVELOPE.
- 10 POST TO BE MEASURED WHEN STRIP IS HELD FLAT.
- 11 POST MUST WITHSTAND TWO 90° BENDS AGAINST EXTRUSION WITHOUT BREAKING.
- 12 DIMENSION SHOULD BE 8.25-10.16 [.325-.400] WHEN MATING WITH A MTA 156 CONNECTOR ASSEMBLY OR 8.25-10.16 [.325-.345] WHEN MATING WITH A SL-156 CONNECTOR ASSEMBLY.
- 13 PLATING: GOLD PLATE AREA, 0.00076 [.000030] GOLD OR 0.00008 [.000003] MIN GOLD FLASH OVER 0.00068 [.000027] PALLADIUM NICKEL, PER TE CONNECTIVITY'S DISCRETION, ALL SIDES, OVER NICKEL UNDERPLATE, 0.00127 [.000050] MIN, ALL SIDES AND ENTIRE LENGTH OF POST.
- 14 BRIGHT TIN/LEAD (93/7) PLATE AREA, 0.00381-0.0089 [.000150-.000350] THICK, ALL FOUR SIDES, 3.18 [.125] MINIMUM.
- 15 MATTE TIN PLATE AREA, [0.00381-0.0089] [.000150-.000350] THICK, ALL FOUR SIDES, 3.18 [.125] MINIMUM.
- 16 OBSOLETE PARTS: OBSOLETE CIS STREAMLINING PER D.RENAUD/D.SINISI

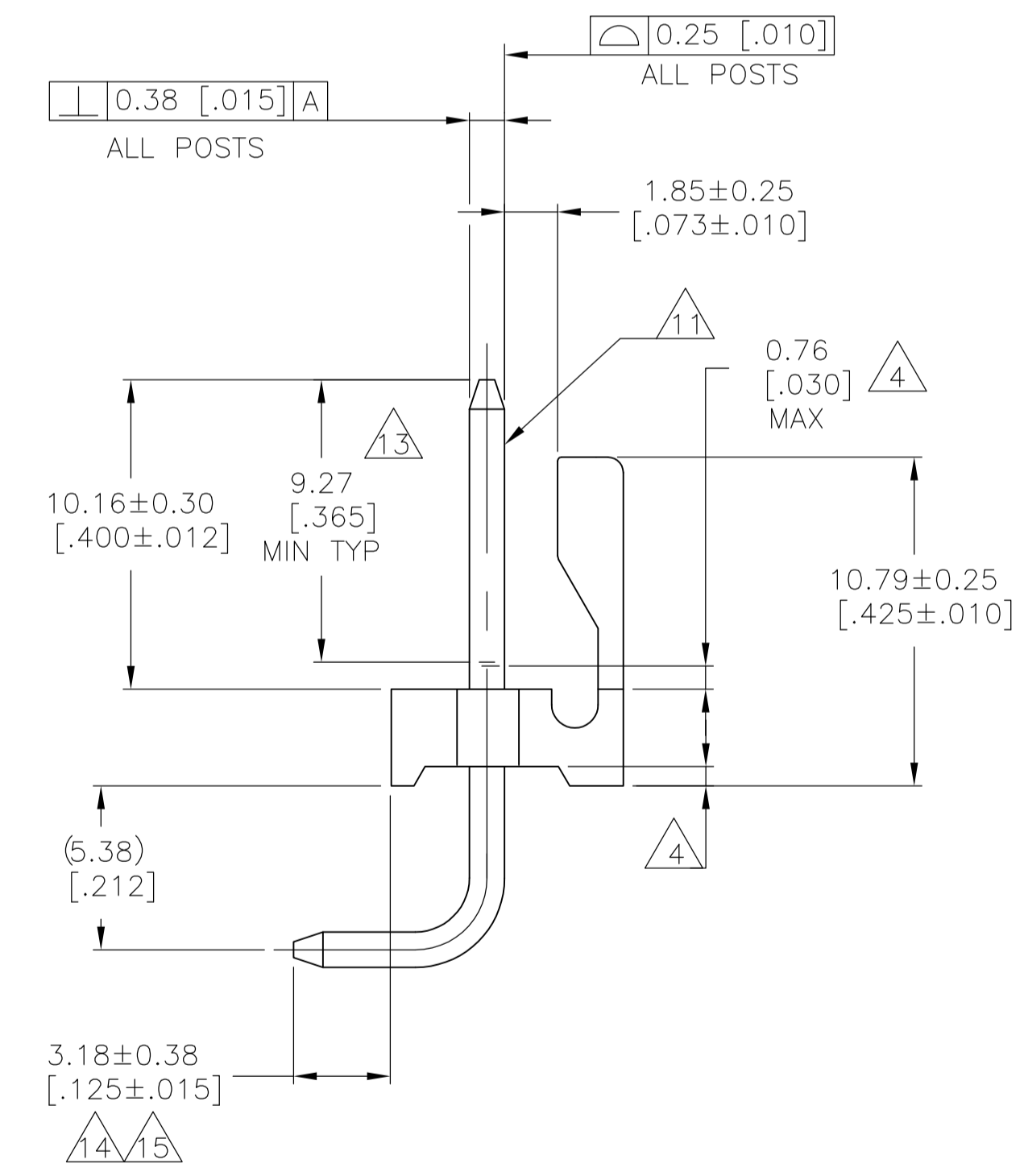
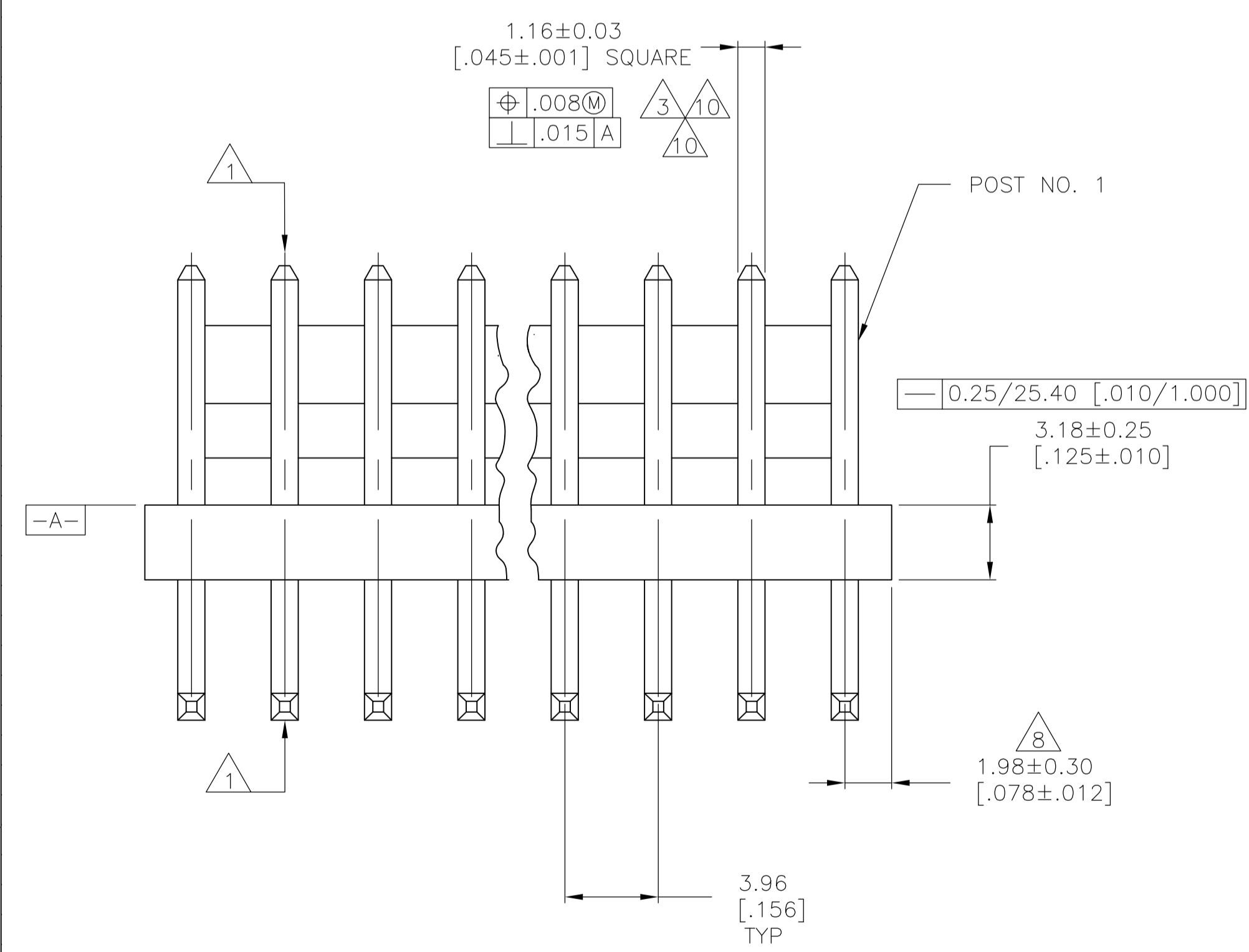
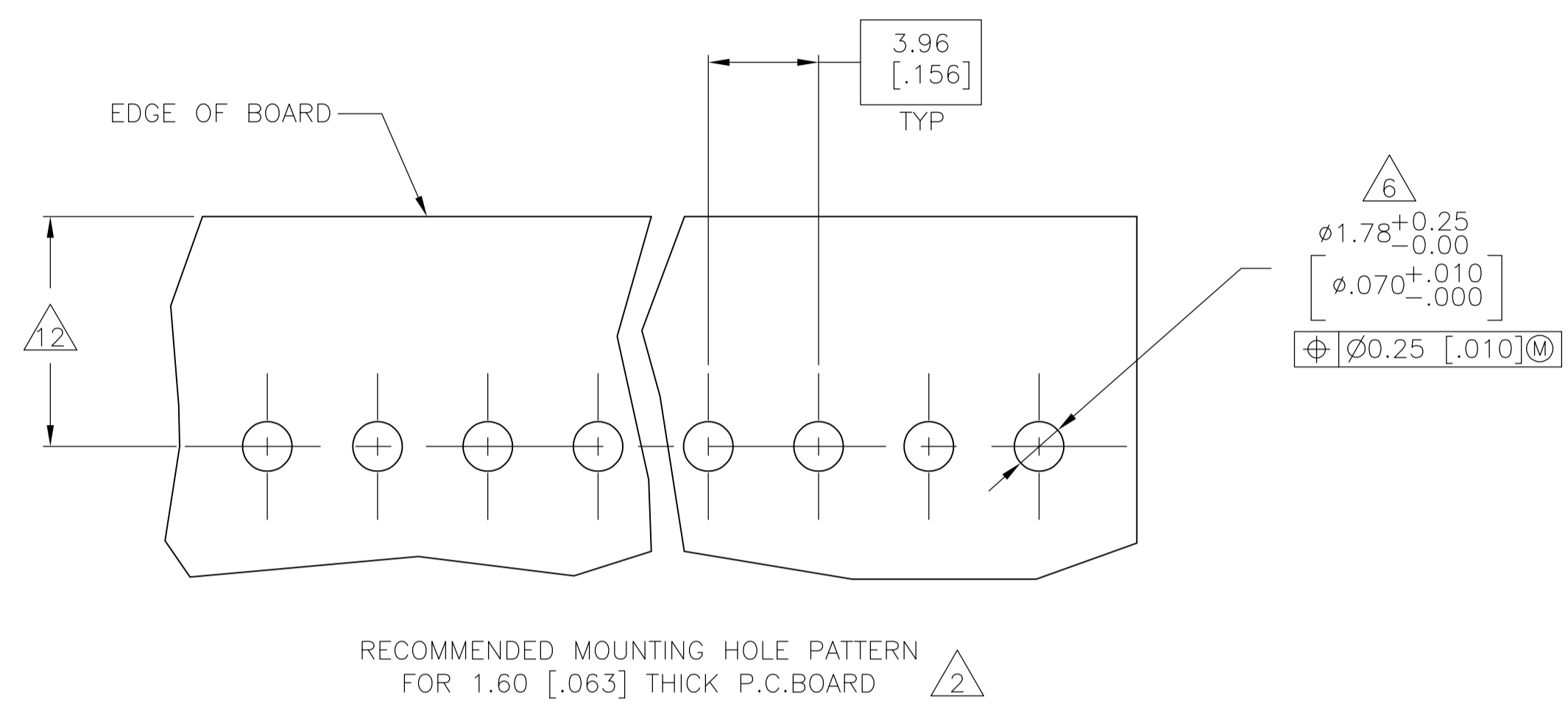
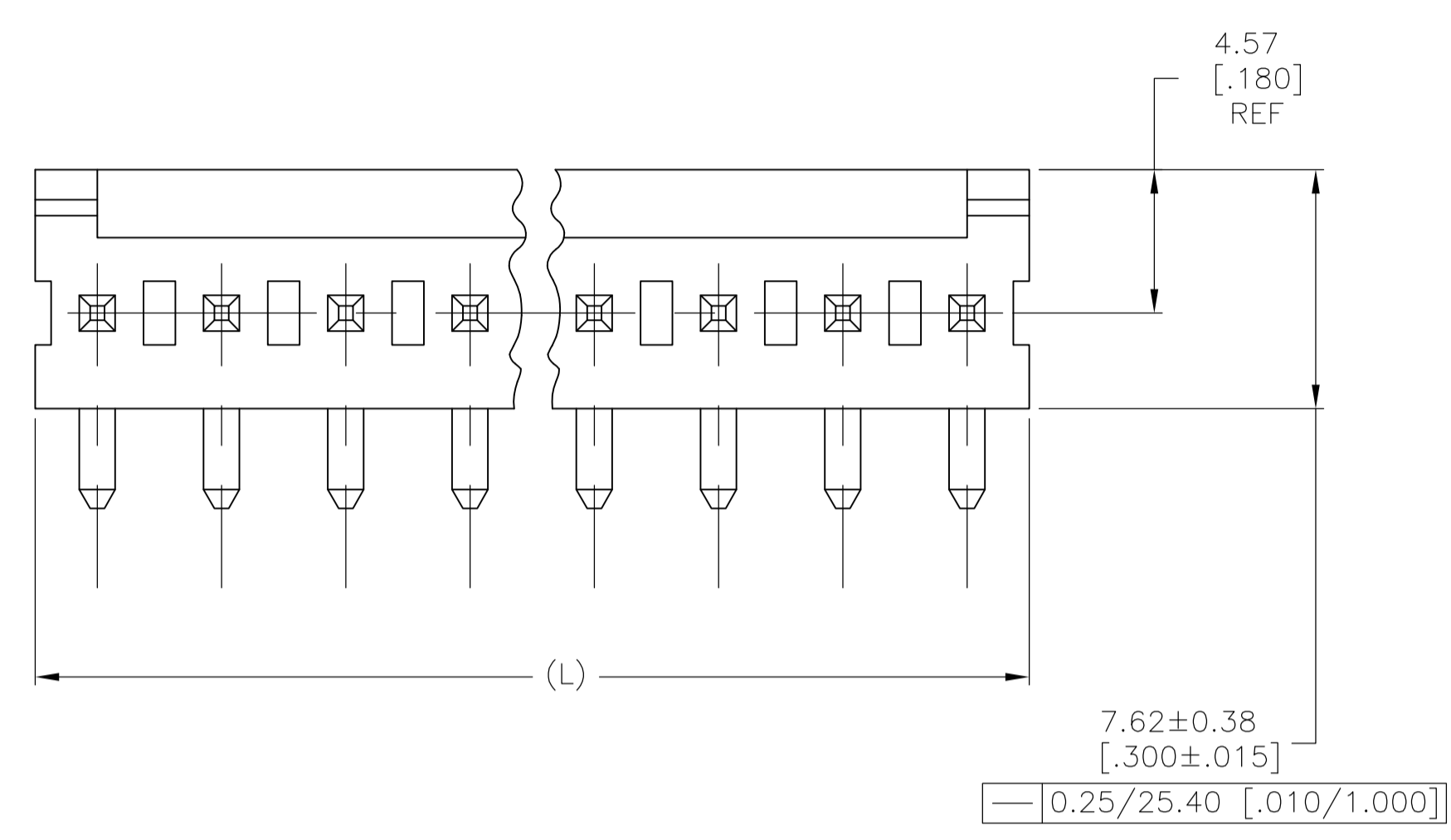

FINISH	MM	[IN]	NO. OF POSN	PART NUMBER
13/15	95.10	3.744	24	5-641210-4
13/15	91.14	3.588	23	5-641210-3
13/15	87.17	3.432	22	5-641210-2
13/15	83.21	3.276	21	5-641210-1
13/15	79.25	3.120	20	5-641210-0
13/15	75.29	2.964	19	4-641210-9
13/15	71.32	2.808	18	4-641210-8
13/15	67.36	2.652	17	4-641210-7
13/15	63.40	2.496	16	4-641210-6
13/15	59.44	2.340	15	4-641210-5
13/15	55.47	2.184	14	4-641210-4
13/15	51.51	2.028	13	4-641210-3
13/15	47.55	1.872	12	4-641210-2
13/15	43.59	1.716	11	4-641210-1
13/15	39.62	1.560	10	4-641210-0
13/15	35.66	1.404	9	3-641210-9
13/15	31.70	1.248	8	3-641210-8
13/15	27.74	1.092	7	3-641210-7
13/15	23.77	.936	6	3-641210-6
13/15	19.81	.780	5	3-641210-5
13/15	15.85	.624	4	3-641210-4
13/15	11.89	.468	3	3-641210-3
13/15	7.92	.312	2	3-641210-2

FINISH	MM	[IN]	NO. OF POSN	PART NUMBER
13/14	95.10	3.744	24	2-641210-4
13/14	91.14	3.588	23	2-641210-3
13/14	87.17	3.432	22	2-641210-2
13/14	83.21	3.276	21	2-641210-1
13/14	79.25	3.120	20	2-641210-0
13/14	75.29	2.964	19	1-641210-9
13/14	71.32	2.808	18	1-641210-8
13/14	67.36	2.652	17	1-641210-7
13/14	63.40	2.496	16	1-641210-6
13/14	59.44	2.340	15	1-641210-5
13/14	55.47	2.184	14	1-641210-4
13/14	51.51	2.028	13	1-641210-3
13/14	47.55	1.872	12	1-641210-2
13/14	43.59	1.716	11	1-641210-1
13/14	39.62	1.560	10	1-641210-0
13/14	35.66	1.404	9	641210-9
13/14	31.70	1.248	8	641210-8
13/14	27.74	1.092	7	641210-7
13/14	23.77	.936	6	641210-6
13/14	19.81	.780	5	641210-5
13/14	15.85	.624	4	641210-4
13/14	11.89	.468	3	641210-3
13/14	7.92	.312	2	641210-2

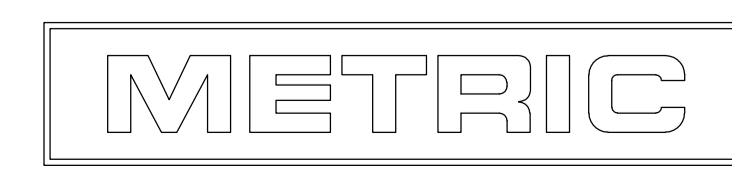

THIS DRAWING IS A CONTROLLED DOCUMENT.

DIMENSIONS: mm [INCHES]	TOLERANCES UNLESS OTHERWISE SPECIFIED:	DIN S. HOOVER 07NOV02	APVD D. ROSSI 07NOV02
0 PLC ± -	1 PLC ± -	NAME	TE Connectivity
2 PLC ± -	3 PLC ± .005	PRODUCT SPEC	MTA-156 HEADER ASSEMBLY, FRICTION LOCK, RIGHT ANGLE, FRONT BEND .045 SQUARE POST, .000030 GOLD
4 PLC ± -	ANGLES ± -	APPLICATION SPEC	RESTRICTED TO
MATERIAL	FINISH	WEIGHT	SIZE CAGE CODE DRAWING NO
			A1 00779 C=641210
		CUSTOMER DRAWING	SCALE 5:1 SHEET 1 OF 1 REV AE