



Chipsmall Limited consists of a professional team with an average of over 10 year of expertise in the distribution of electronic components. Based in Hongkong, we have already established firm and mutual-benefit business relationships with customers from,Europe,America and south Asia,supplying obsolete and hard-to-find components to meet their specific needs.

With the principle of “Quality Parts,Customers Priority,Honest Operation,and Considerate Service”,our business mainly focus on the distribution of electronic components. Line cards we deal with include Microchip,ALPS,ROHM,Xilinx,Pulse,ON,Everlight and Freescale. Main products comprise IC,Modules,Potentiometer,IC Socket,Relay,Connector.Our parts cover such applications as commercial,industrial, and automotives areas.

We are looking forward to setting up business relationship with you and hope to provide you with the best service and solution. Let us make a better world for our industry!



Contact us

Tel: +86-755-8981 8866 Fax: +86-755-8427 6832

Email & Skype: info@chipsmall.com Web: www.chipsmall.com

Address: A1208, Overseas Decoration Building, #122 Zhenhua RD., Futian, Shenzhen, China



8

7

6

5

4

3

2

1

VICOR CONFIDENTIAL

THIS DOCUMENT AND THE DATA DISCLOSED HEREIN OR HEREWITH IS NOT TO BE REPRODUCED, USED OR DISCLOSED IN WHOLE OR IN PART TO ANYONE WITHOUT THE PERMISSION OF VICOR CORP.

REV.	DESCRIPTION		DATE	APPROVED
1	RELEASED PER E050349	PEI	11/15/05	ECF
2	REVISED PER E100622	GCK	04/28/10	REJH
3	REVISED PER E100872	KUK	06/30/10	DCS
4	REVISED PER E120629	ZMB	07/02/12	SJ
5	REVISED PER E120794	SJ	08/30/12	REJH
6	REVISED PER E131431	GCK	10/8/13	TO

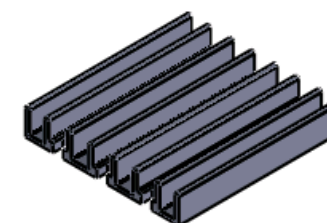
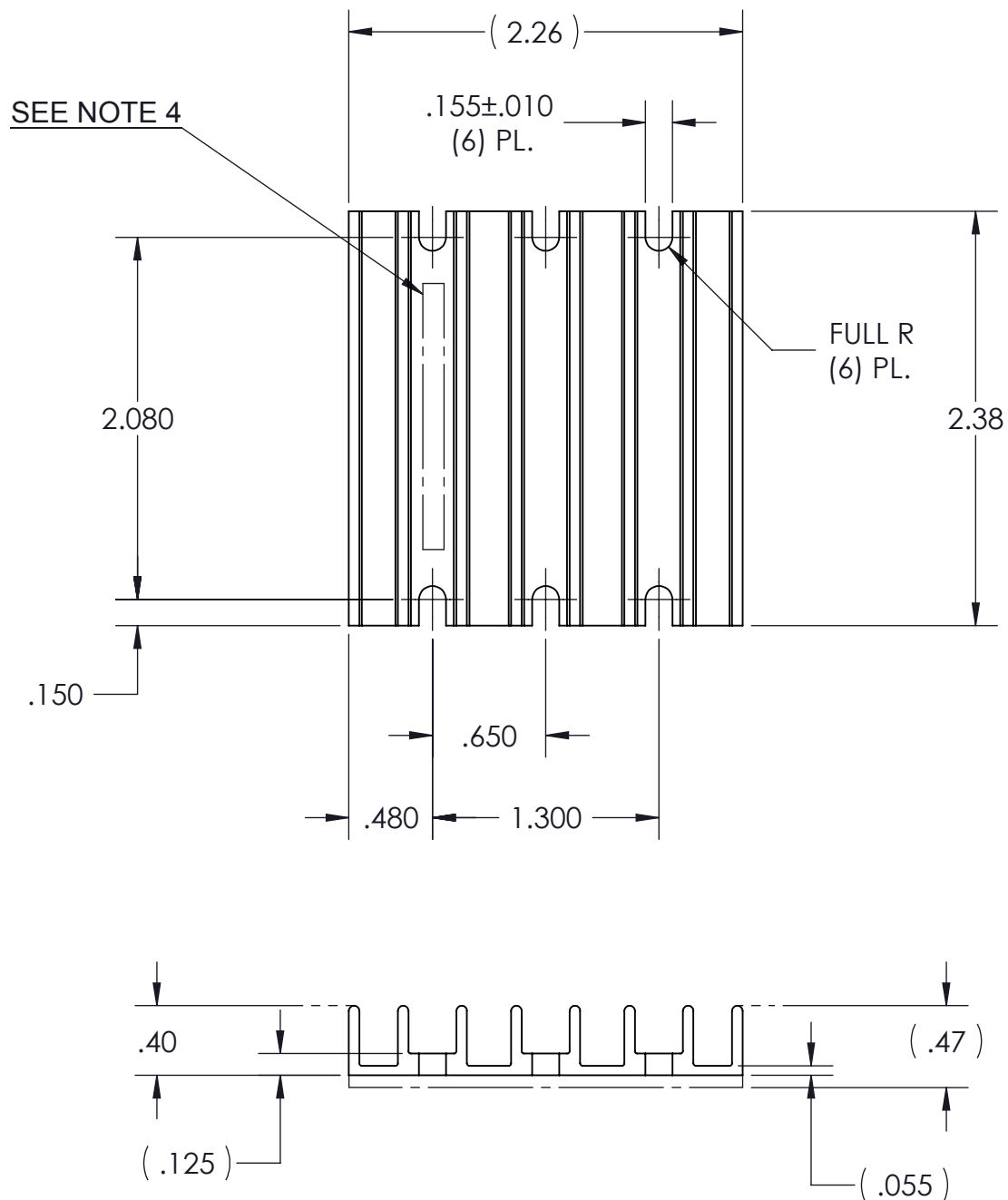

NOTES

1. MATERIAL: EXTRUSION SEE SHEET 2 OF 2
2. CLEAR FINISH, RoHS COMPLIANT PER CST-0001, LATEST REVISION PER A.) CHROMIUM FREE, OR B.) TRIVALENT CHROMIUM IN ACCORDANCE WITH MIL-DTL-5541, TYPE II, CLASS 1A OR 3. SEE CST-0003 FOR TYPES OF AVAILABLE FINISHES.
- <> 3. REMOVE ALL LOOSE BURRS.
4. MECHANICALLY STAMP OR USE WHITE EPOXY INK FOR PART NUMBER. REVISION LEVEL NOT REQUIRED, BUT MAY BE INCLUDED AT THE FABRICATOR'S DISCRETION.
5. <> DENOTES CRITICAL CHARACTERISTIC FOR LOT INSPECTION.
6. DIMENSIONS ARE INCHES ONLY.

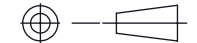
DRAWN BY	DATE	 SWD			
P.E.IENI	05/14/2010				
UNLESS OTHERWISE SPECIFIED DIMENSIONS ARE : INCH / [MM]		HEATSINK XFLOW MINI-MOD .40 HG			
TOLERANCES ARE:					
DECIMALS	ANGLES				
X.XX [X.X] = ±0.01 [0.25]	±1°	SIZE	CAGE CODE	DWG NO	REV
X.XXX [X.XX] = ±0.005 [0.127]		B	67131	30140	6
THIRD ANGLE PROJECTION		SCALE 1:1		SHEET 1 OF 2	
 DO NOT SCALE DRAWING					

8

7

6

5

4

3

2

1

8

7

6

5

4

3

2

1

VICOR CONFIDENTIAL

THIS DOCUMENT AND THE DATA DISCLOSED HEREIN OR HEREWITH IS NOT TO BE REPRODUCED, USED OR DISCLOSED IN WHOLE OR IN PART TO ANYONE WITHOUT THE PERMISSION OF VICOR CORP.

REVISIONS

REV	DESCRIPTION	DATE	APPROVED
	SEE SHEET 1		

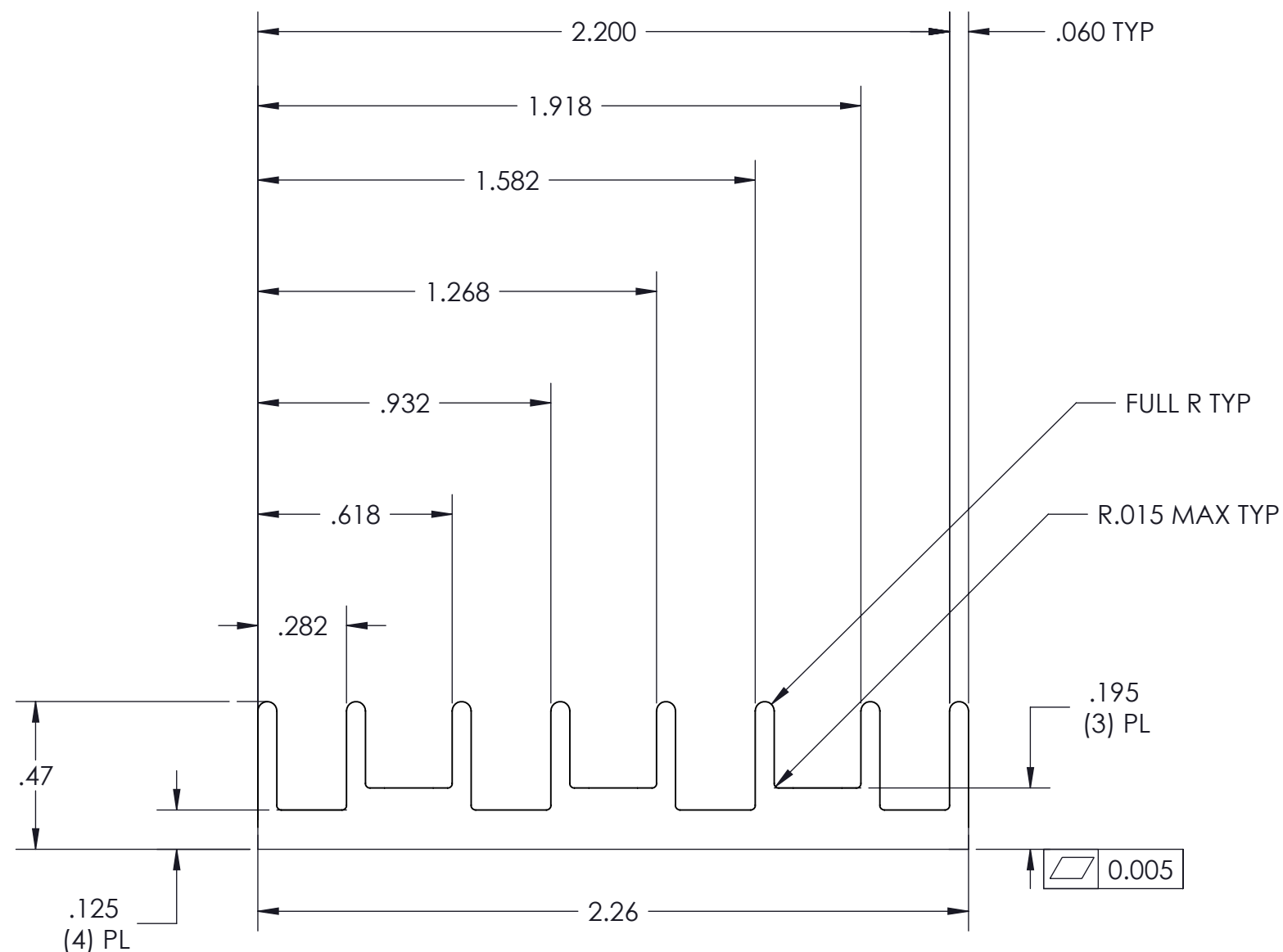

PROFILE COMMON FOR
30140

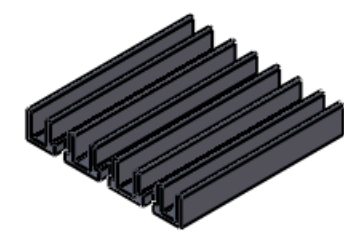

NOTES:

1. MATERIAL ALUMINIUM: 6063-T5
2. BREAK ALL EDGES AND SHARP CORNERS.
3. RoHS COMPLIANT PER CST-0001 LATEST REVISION.
4. DIMENSIONS ARE INCHES ONLY.

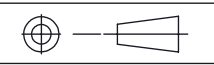
DRAWN BY P.E.IENI	DATE 05/14/2010	 HEATSINK XFLOW MINI-MOD .40 HG		REV 6
<small>UNLESS OTHERWISE SPECIFIED DIMENSIONS ARE : INCH / [MM]</small> <small>TOLERANCES ARE:</small> <small>DECIMALS</small> X.XX [X.X] = ±0.01 [0.25] <small>ANGLES</small> ±1° <small>X.XXX [X.XX] = ±0.005 [0.127]</small>				SIZE B
<small>THIRD ANGLE PROJECTION</small>  <small>DO NOT SCALE DRAWING</small>		SCALE 2:1	SHEET 2 OF 2	

8

7

6

5

4

3

2

1