



Chipsmall Limited consists of a professional team with an average of over 10 year of expertise in the distribution of electronic components. Based in Hongkong, we have already established firm and mutual-benefit business relationships with customers from,Europe,America and south Asia,supplying obsolete and hard-to-find components to meet their specific needs.

With the principle of “Quality Parts,Customers Priority,Honest Operation,and Considerate Service”,our business mainly focus on the distribution of electronic components. Line cards we deal with include Microchip,ALPS,ROHM,Xilinx,Pulse,ON,Everlight and Freescale. Main products comprise IC,Modules,Potentiometer,IC Socket,Relay,Connector.Our parts cover such applications as commercial,industrial, and automotives areas.

We are looking forward to setting up business relationship with you and hope to provide you with the best service and solution. Let us make a better world for our industry!



Contact us

Tel: +86-755-8981 8866 Fax: +86-755-8427 6832

Email & Skype: info@chipsmall.com Web: www.chipsmall.com

Address: A1208, Overseas Decoration Building, #122 Zhenhua RD., Futian, Shenzhen, China



8

7

6

5

4

3

2

1

VICOR CONFIDENTIAL

THIS DOCUMENT AND THE DATA DISCLOSED HEREIN OR HEREWITH IS NOT TO BE REPRODUCED, USED OR DISCLOSED IN WHOLE OR IN PART TO ANYONE WITHOUT THE PERMISSION OF VICOR CORP.

REV.	DESCRIPTION	INTL	DATE	APVD
1	RELEASED PER E050350	LEK	11/16/05	EF
2	REVISED PER E100841	KUK	06/22/10	GCK
3	REVISED PER E131632	GCK	11/21/2013	TO

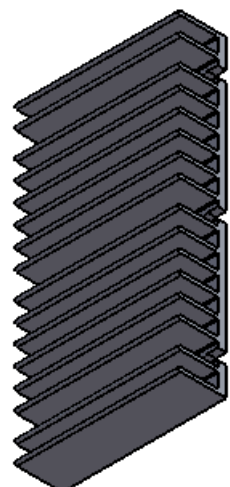
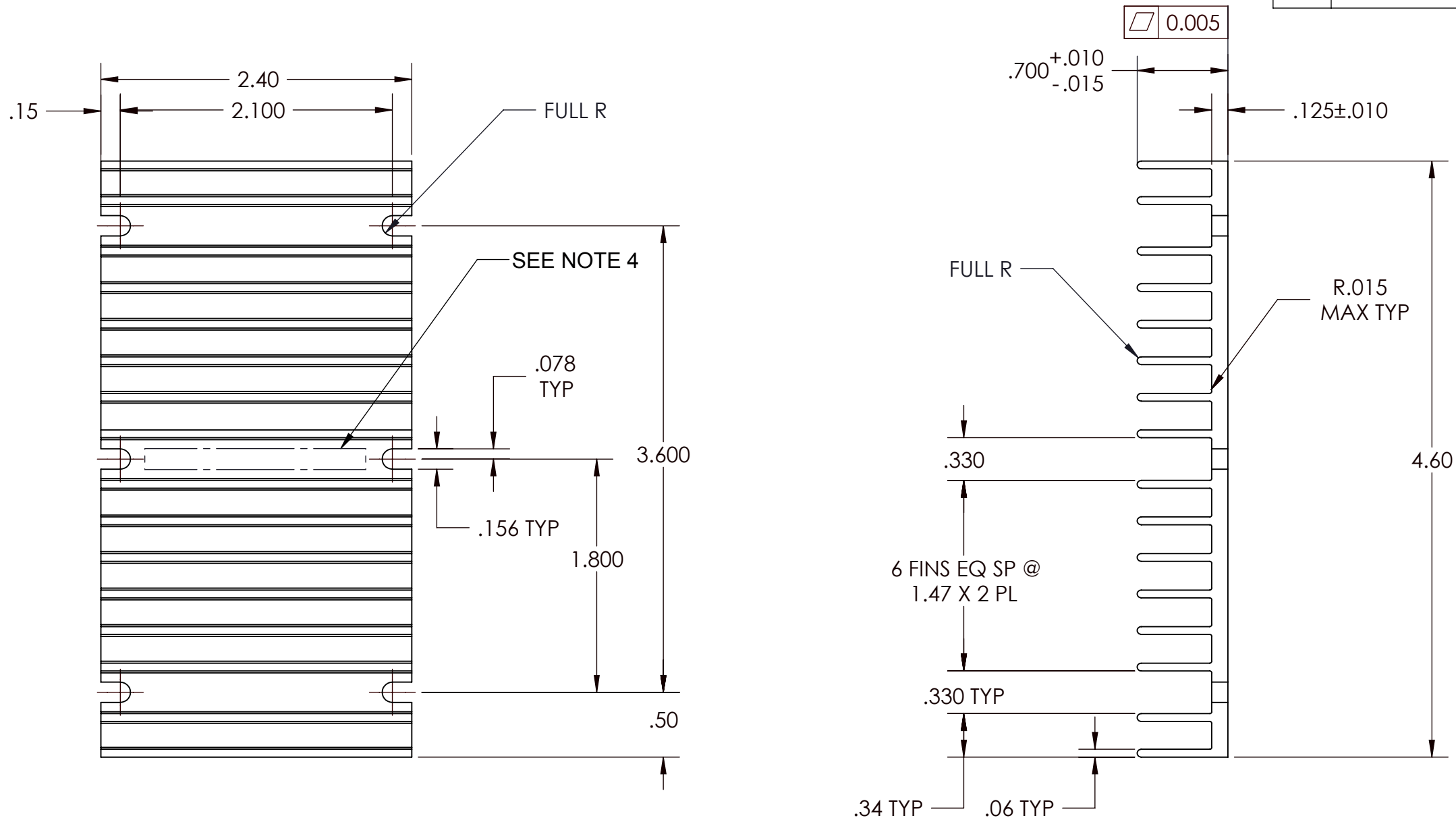

NOTES:

1. MATERIAL: AL. 6063-T5.
2. REMOVE ALL LOOSE AND HANGING BURRS. OTHERWISE, BURRS SHALL NOT EXCEED .003.
- <> 3. CLEAR FINISH RoHS COMPLIANT PER CST-0001, LATEST REVISION PER: A) CHROMIUM FREE OR B.) TRIVALENT CHROMIUM IN ACCORDANCE WITH MIL-D-5541 TYPE II, CLASS 1A OR 3. SEE CST-0003 FOR TYPES OF AVAILABLE FINISHES.
4. MECHANICALLY STAMP OR USE WHITE OR BLACK EPOXY INK FOR PART NUMBER.
5. <> DENOTES CRITICAL CHARACTERISTIC FOR LOT INSPECTION.
6. TOLERANCE ON ALL DIMENSIONS SHOWN AS REFERENCE SHALL FOLLOW STANDARD ALUMINUM ASSOCIATION TOLERANCE.

DRAWN BY Krishna Kamath	DATE 05/14/2010	VICOR		SWD	
UNLESS OTHERWISE SPECIFIED DIMENSIONS ARE : INCH / [MM]		HS XF 17.78MM			
TOLERANCES ARE: DECIMALS ANGLES X.XX [X.X] = ±0.01 [0.25] ±1° X.XXX [X.XX] = ±0.005 [0.127]		SIZE B	CAGE CODE 67131	DWG NO 30193	REV 3
THIRD ANGLE PROJECTION DO NOT SCALE DRAWING		SCALE 1:1	SHEET 1 OF 1		

8

7

6

5

4

3

2

1