



Chipsmall Limited consists of a professional team with an average of over 10 year of expertise in the distribution of electronic components. Based in Hongkong, we have already established firm and mutual-benefit business relationships with customers from,Europe,America and south Asia,supplying obsolete and hard-to-find components to meet their specific needs.

With the principle of “Quality Parts,Customers Priority,Honest Operation,and Considerate Service”,our business mainly focus on the distribution of electronic components. Line cards we deal with include Microchip,ALPS,ROHM,Xilinx,Pulse,ON,Everlight and Freescale. Main products comprise IC,Modules,Potentiometer,IC Socket,Relay,Connector.Our parts cover such applications as commercial,industrial, and automotives areas.

We are looking forward to setting up business relationship with you and hope to provide you with the best service and solution. Let us make a better world for our industry!



## Contact us

Tel: +86-755-8981 8866 Fax: +86-755-8427 6832

Email & Skype: info@chipsmall.com Web: www.chipsmall.com

Address: A1208, Overseas Decoration Building, #122 Zhenhua RD., Futian, Shenzhen, China



THESE DRAWINGS ARE THE PROPERTY OF QUALTEK ELECTRONICS AND NOT TO BE REPRODUCED FOR OR COMMUNICATED TO A THIRD PARTY WITHOUT THE EXPRESS WRITTEN PERMISSION OF AN OFFICER OF QUALTEK ELECTRONICS.

REVISION			
REV.	DESCRIPTION	DATE	APPROVED

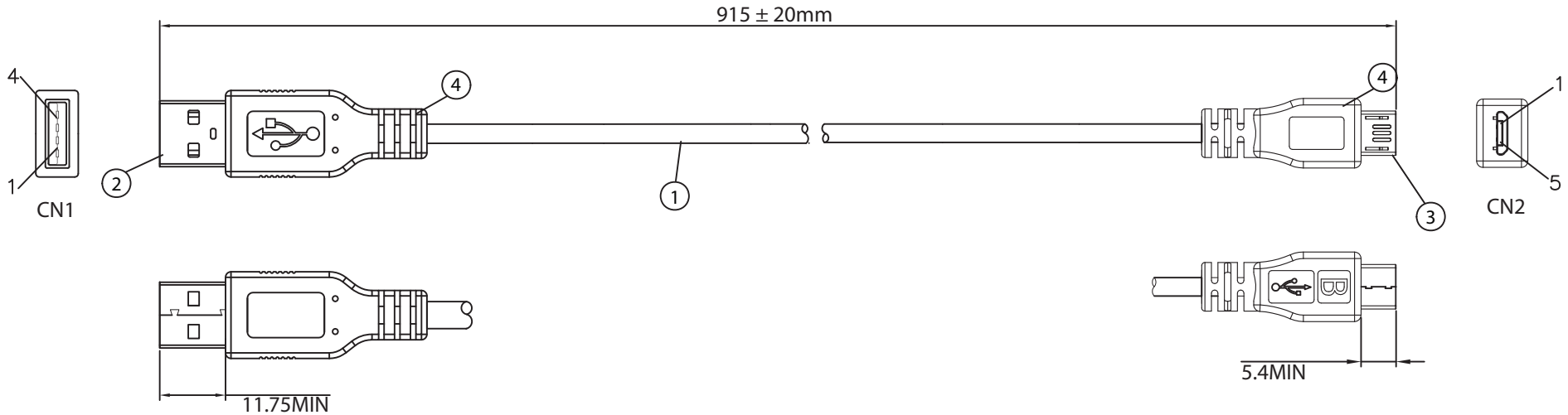

CONNECTION

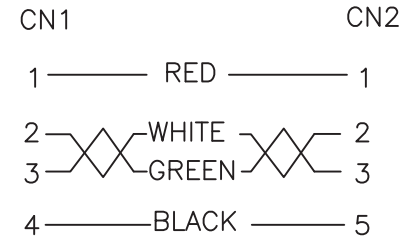

SHELL — BRAID & DRAIN — SHELL

NOTES:

1. CABLE: UL2725  
28AWG\*1PR+28AWG\*2C+AEB(AL) 65%  
OUTER JACKET: WHITE, OD: 4.0 ± 0.2mm
2. CONNECTOR: USB A TYPE MALE  
INSULATOR: WHITE PBT  
PIN G/F  
NICKEL PLATED SHELL
3. CONNECTOR: MICRO USB B TYPE MALE  
INSULATOR: BLACK  
PIN G/F  
NICKEL PLATED SHELL
4. PVC MOLDED: 45P WHITE
5. ELECTRICAL TEST:  
<1>.100% OPEN SHORT & MISS WIRE TEST  
<2>.INSULATION RESISTANCE: DC300V 10M ohm MIN.  
<3>.CONDUCTOR RESISTANCE: 2 ohm MAX.

**CONTROLLED**

Dim range (mm)	Tolerance +/- (mm)	<b>Qualtek Electronics Corp.</b> WCI DIVISION		
		Part Number: 3025010-03		<span style="border: 1px solid green; padding: 2px;">RoHS Compliant</span>
0-1	0.15	Description: USB 4P(A)/M - MICRO USB 5P(B)/M		
1-6	0.20			
6-18	0.30	RFQ# 2505D	UNIT: mm	
18-50	0.50			
50-120	0.70	Drawn / Date	Checked / Date	Approved / Date
120-250	0.90	R. Nuti 06-13-13	06-13-13	LY / 06-13-13
250-500	1.20			