



Chipsmall Limited consists of a professional team with an average of over 10 year of expertise in the distribution of electronic components. Based in Hongkong, we have already established firm and mutual-benefit business relationships with customers from,Europe,America and south Asia,supplying obsolete and hard-to-find components to meet their specific needs.

With the principle of “Quality Parts,Customers Priority,Honest Operation,and Considerate Service”,our business mainly focus on the distribution of electronic components. Line cards we deal with include Microchip,ALPS,ROHM,Xilinx,Pulse,ON,Everlight and Freescale. Main products comprise IC,Modules,Potentiometer,IC Socket,Relay,Connector.Our parts cover such applications as commercial,industrial, and automotives areas.

We are looking forward to setting up business relationship with you and hope to provide you with the best service and solution. Let us make a better world for our industry!



Contact us

Tel: +86-755-8981 8866 Fax: +86-755-8427 6832

Email & Skype: info@chipsmall.com Web: www.chipsmall.com

Address: A1208, Overseas Decoration Building, #122 Zhenhua RD., Futian, Shenzhen, China



VICOR CONFIDENTIAL
 THIS DOCUMENT AND THE DATA DISCLOSED HEREIN OR
 HEREWITH IS NOT TO BE REPRODUCED, USED OR
 DISCLOSED IN WHOLE OR IN PART TO ANYONE WITHOUT
 THE PERMISSION OF VICOR CORP.

REV.	DESCRIPTION	DATE	APPROVED
1	RELEASED PER E050348	11/15/05	ECF
2	REVISED PER E072386	10/02/07	REJH
3	REVISED PER E090033	01/09/09	REJH
4	REVISED PER E091548	09/03/09	REJH
5	REVISED PER E100902	7/14/10	KUK
6	REVISED PER E111105	11/11/11	REJH

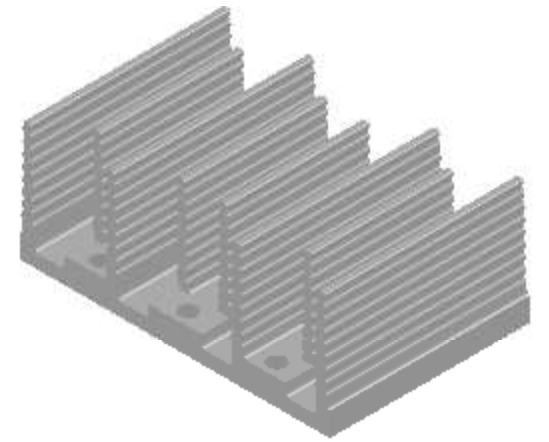
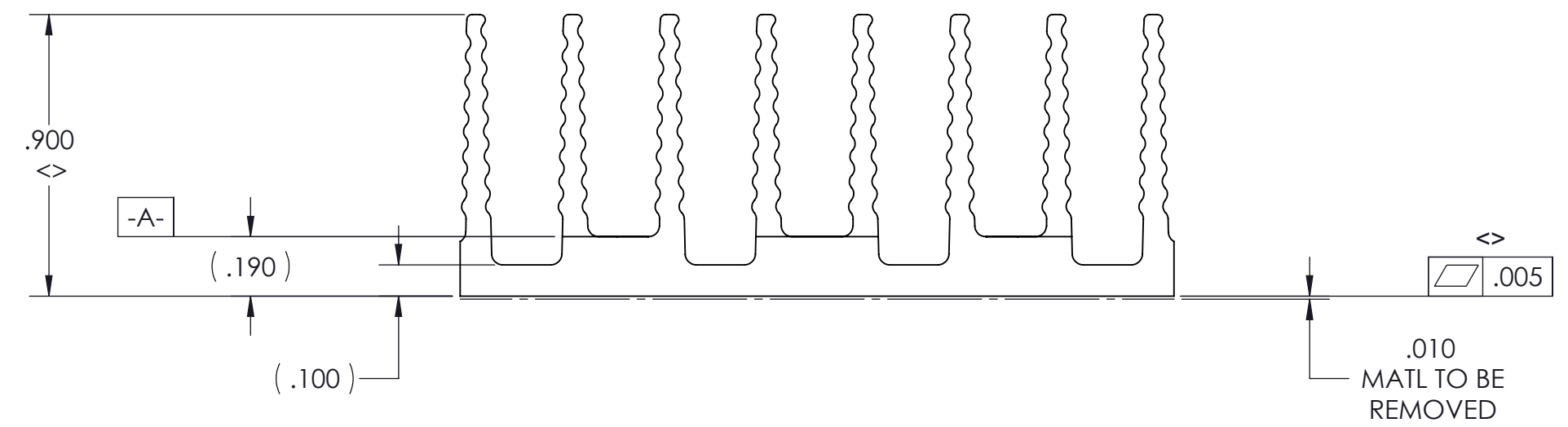
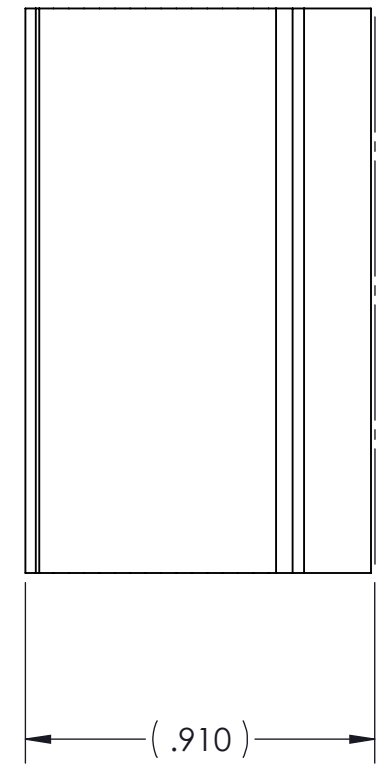
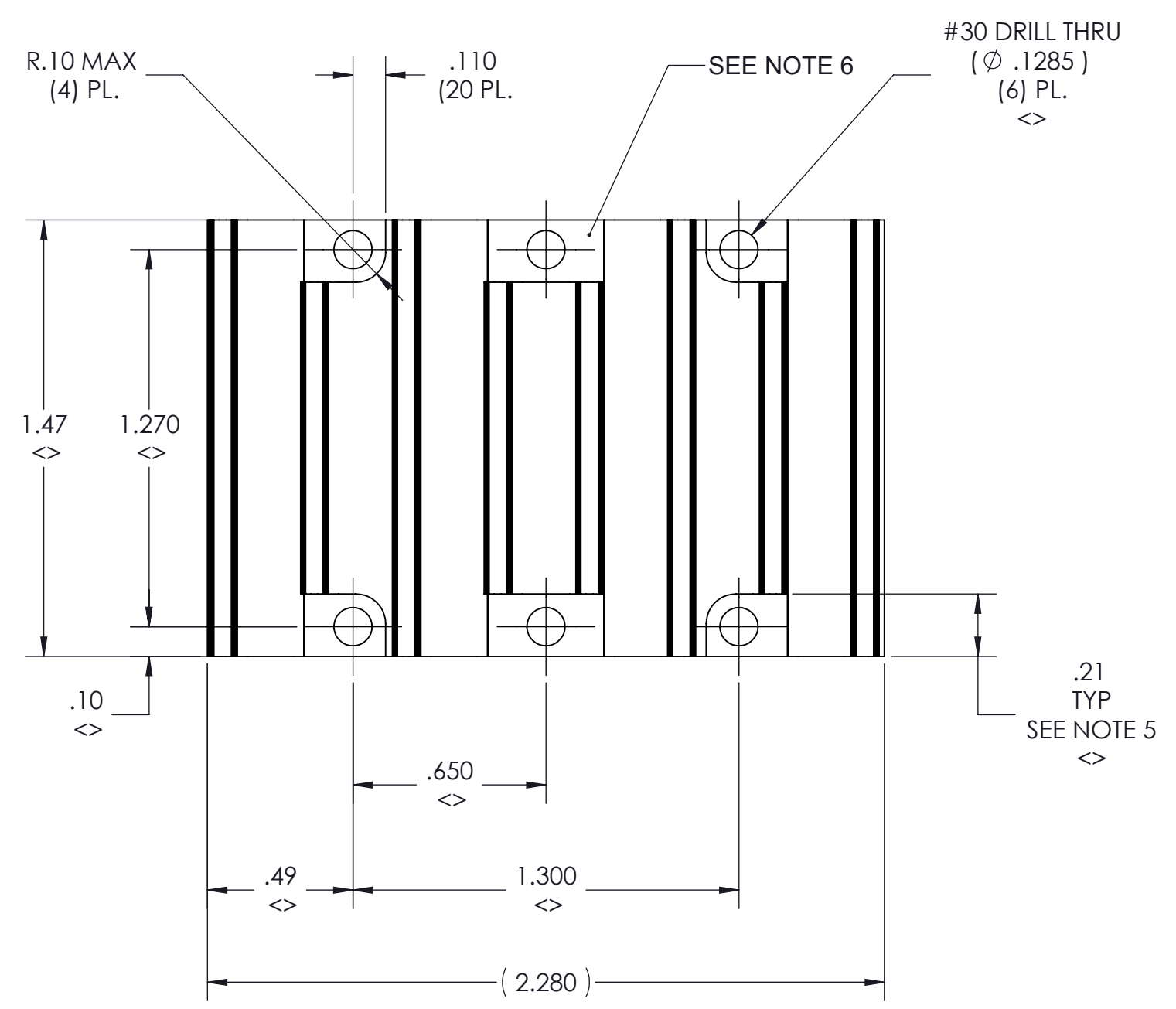

- NOTES:
 1. MATERIAL: EXTRUSION SEE SHEET 2 OF 2.
 2. REMOVE ALL BURRS AND SHARP EDGES.
 <>3. CLEAR FINISH, RoHS COMPLIANT, PER CST-0001
 LATEST REVISION PER:
 A.) CHROMIUM FREE, OR
 B.) TRIVALENT CHROMIUM IN ACCORDANCE WITH
 MIL-DTL-5541, TYPE II CLASS 1A OR 3.
 SEE CST-0003 FOR TYPES OF AVAILABLE FINISHES
 4. "<>" DENOTES CRITICAL CHARACTERISTIC FOR LOT INSPECTION.
 5. DIMENSIONS APPLIES AT SURFACE -A- (2) PL.
 6. MACHINED SURFACE TO BE .010 MAX BELOW SURFACE -A- (6) PL.
 7. DIMENSIONS ARE INCHES ONLY.

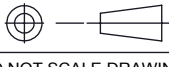
DRAWN BY David Schmidt	DATE 06/28/2010	VICOR SWD		
UNLESS OTHERWISE SPECIFIED DIMENSIONS ARE : INCH / (MM)		HTSNK, "C" X-FLOW, .9H LOW FLOW, THRU HOLE		
TOLERANCES ARE: DECIMALS ANGLES X.XX [X.X] = ±0.01 [0.25] ±1° X.XXX [X.XX] = ±0.005 [0.127]				
THIRD ANGLE PROJECTION  DO NOT SCALE DRAWING	SIZE C	CAGE CODE 67131	DWG NO 30725	REV 6
SCALE 2:1		SHEET 1 OF 2		

VICOR CONFIDENTIAL
THIS DOCUMENT AND THE DATA DISCLOSED HEREIN OR
HEREWITH IS NOT TO BE REPRODUCED, USED OR
DISCLOSED IN WHOLE OR IN PART TO ANYONE WITHOUT
THE PERMISSION OF VICOR CORP.

REVISIONS			
REV	DESCRIPTION	DATE	APPROVED
	SEE SHEET 1		

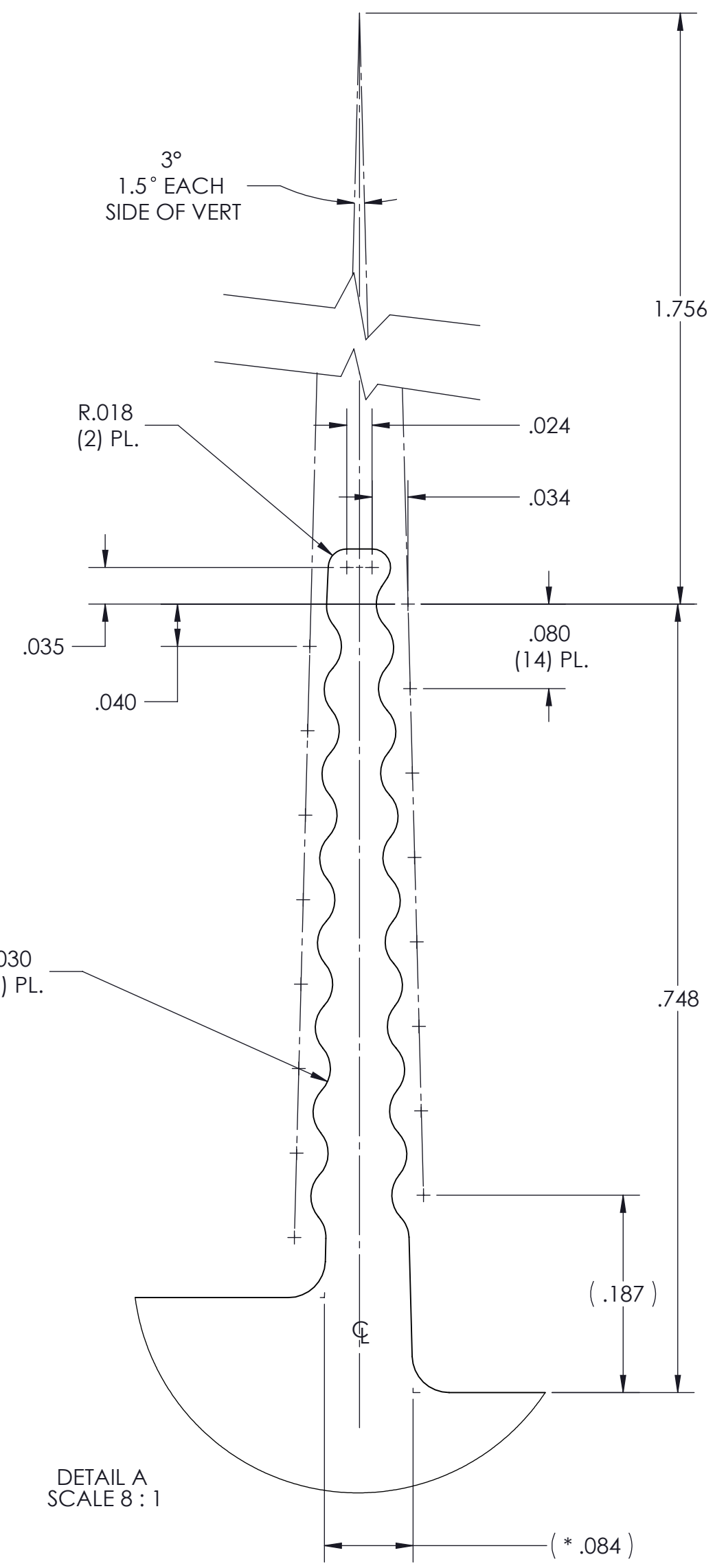
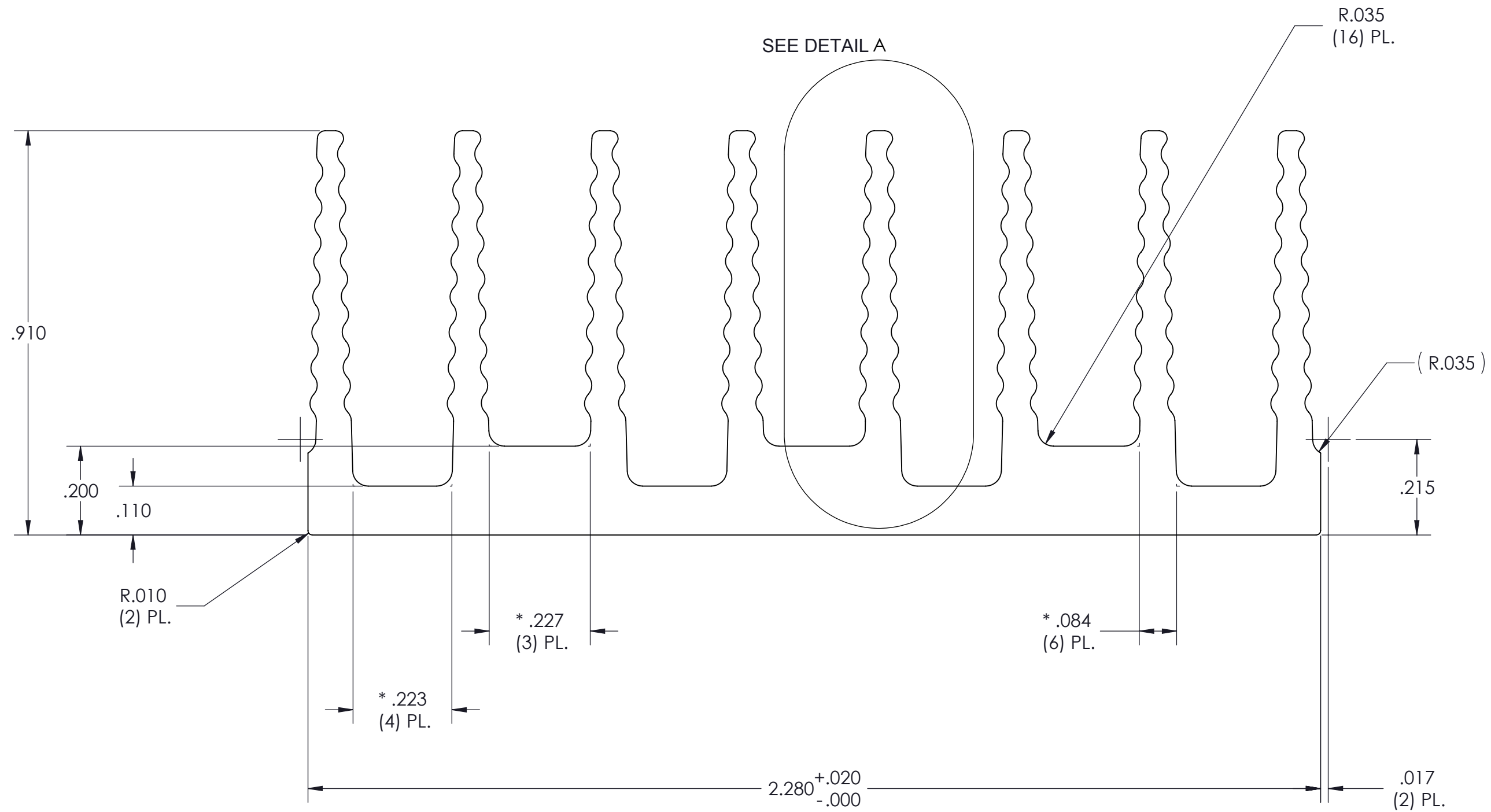

PROFILE COMMON FOR
30270
30724
30269
30725

- NOTES:
- MATL: ALUMINUM 6063-T5
 - * DENOTES DIMENSION TO THEORETICAL SHARP CORNER.
 - ALL DIMENSIONS ARE CRITICAL CHARACTERISTICS.
 - RoHS COMPLIANT PER CST-0001 LATEST REVISION.
 - WORKMANSHIP STANDARDS WS-0004, WS-0006 AND WS-0007 APPLY TO THIS PART.
 - DIMENSIONS ARE INCHES ONLY.

DRAWN BY David Schmidt	DATE 06/28/2010	SWD	
UNLESS OTHERWISE SPECIFIED DIMENSIONS ARE : INCH / (MM)		HTSNK, "C" X-FLOW, .9H LOW FLOW, THRU HOLE EXTRUSION	
TOLERANCES ARE: DECIMALS ANGLES X.XX [X.X] = ±0.01 [0.25] ±1° X.XXX [X.XXX] = ±0.005 [0.127]			
THIRD ANGLE PROJECTION 	SIZE C	CAGE CODE 67131	DWG NO 30725
DO NOT SCALE DRAWING	SCALE 2:1	REV 6	
		SHEET 2 OF 2	