



Chipsmall Limited consists of a professional team with an average of over 10 year of expertise in the distribution of electronic components. Based in Hongkong, we have already established firm and mutual-benefit business relationships with customers from,Europe,America and south Asia,supplying obsolete and hard-to-find components to meet their specific needs.

With the principle of “Quality Parts,Customers Priority,Honest Operation,and Considerate Service”,our business mainly focus on the distribution of electronic components. Line cards we deal with include Microchip,ALPS,ROHM,Xilinx,Pulse,ON,Everlight and Freescale. Main products comprise IC,Modules,Potentiometer,IC Socket,Relay,Connector.Our parts cover such applications as commercial,industrial, and automotives areas.

We are looking forward to setting up business relationship with you and hope to provide you with the best service and solution. Let us make a better world for our industry!



## Contact us

Tel: +86-755-8981 8866 Fax: +86-755-8427 6832

Email & Skype: info@chipsmall.com Web: www.chipsmall.com

Address: A1208, Overseas Decoration Building, #122 Zhenhua RD., Futian, Shenzhen, China



Shock-Safe Fuseholder, 5 x 20 mm, Slotted Cap/Fingerrip, horizontal, IEC 60335-1



Fingerrip

250 VAC · 2.5W/10A (VDE) · 500V · 16A (UL/CSA)



### Description

- Meets the new requirements of IEC 60335-1 for appliances in unattended use (clause 30.2.3). This includes the enhanced requirements of glow wire tests acc. to IEC 60695-2-12 and -13.
- Horizontal style

### Standards

- IEC 60127-6 Edition 2.0
- UL 4248-1
- CSA C22.2 no. 4248.1

### Approvals

- VDE Certificate Number: 129098
- UL File Number: E39328

### Applications

- Household appliances
- Medical equipment

### Weblinks

[pdf datasheet](#), [html-datasheet](#), [General Product Information](#), [Packaging details](#), [Approvals](#), [CE declaration of conformity](#), [RoHS](#), [CHINA-RoHS](#), [REACH](#), [Distributor-Stock-Check](#), [Detailed request for product](#)

### Technical Data

Shock-Safe Category	PC2
Fuse-Link	5 x 20mm
Mounting	PCB
Terminal	Solder THT
Rated Voltage	250VAC , 500V (UL/CSA)
Rated current	10A (VDE), 16A (UL/CSA)
Rated Power Acceptance IEC	2.5W / 10A @ Ta 23°C Admissible power acceptance at higher ambient temperature see derating curves
Degree of Protection	IP 40
Protection Class	Suitable for appliances with protection class I acc. to IEC 61140
Admissible Ambient Air Temp.	-40°C to 85°C
Climatic Category	40/085/21 acc. to IEC 60068-1
Material: Socket	Thermoplastic, black, UL 94V-0
Material: Terminals	Tin-Plated Copper Alloy
Unit Weight	4.31 g
Storage Conditions	0°C to 60°C, max. 70% r.h.
Product Marking	 , Type, Rated Voltage, Power Acc./Current Rating, Approvals

Soldering Methods	Wave <a href="#">Soldering Profile</a>
Solderability	235°C / 2 sec acc. to IEC 60068-2-20, Test Ta, method 1
Resistance to Soldering Heat	260°C / 10sec acc. to IEC 60068-2-20, Test Tb, method 1A
Contact Resistance	≤ 10mΩ at 20 mV acc. to IEC 60127-6
Dielectric Strength	> 3kV (50Hz; 1 min)
Impulse Withstand Voltage	> 2.5kV between L-N
Insulation Resistance	> 10MΩ between L-N (500VDC; 1 min)
Overvoltage Category	II acc. to IEC 60664-1
Pollution Degree	2 acc. to IEC 60664-1
Resistance to Vibration	acc. to IEC 60068-2-6, test Fc

Detailed information on product approvals, code requirements, usage instructions and detailed test conditions can be looked up in [General Product Information](#)

Dimension

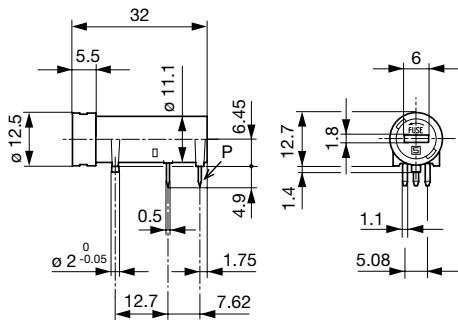

Variant 3101.0050

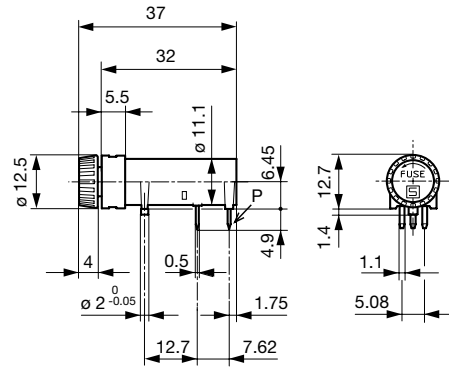

Variant Fingergrasp 3101.0055 / Connector tinned

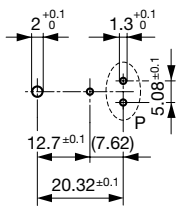

Drilling diagram

Derating Curves

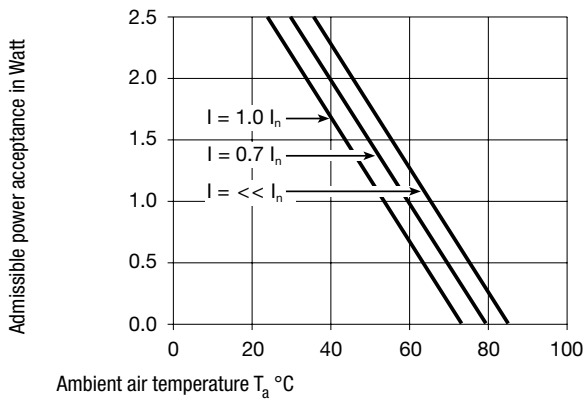

All Variants

Holder	Cap	Terminal	Material	Remark	Order Number
●	slotted	straight	Thermoplastic	-	3101.0050
●	Fingergrasp	straight	Thermoplastic	-	3101.0055

Most Popular.

Availability for all products can be searched real-time: <http://www.schurter.com/en/Stock-Check/Stock-Check-SCHURTER>

Packaging Unit

Bulk 186 x 91 x 91 mm (100 pcs.)