



Chipsmall Limited consists of a professional team with an average of over 10 year of expertise in the distribution of electronic components. Based in Hongkong, we have already established firm and mutual-benefit business relationships with customers from,Europe,America and south Asia,supplying obsolete and hard-to-find components to meet their specific needs.

With the principle of “Quality Parts,Customers Priority,Honest Operation,and Considerate Service”,our business mainly focus on the distribution of electronic components. Line cards we deal with include Microchip,ALPS,ROHM,Xilinx,Pulse,ON,Everlight and Freescale. Main products comprise IC,Modules,Potentiometer,IC Socket,Relay,Connector.Our parts cover such applications as commercial,industrial, and automotives areas.

We are looking forward to setting up business relationship with you and hope to provide you with the best service and solution. Let us make a better world for our industry!



## Contact us

Tel: +86-755-8981 8866 Fax: +86-755-8427 6832

Email & Skype: info@chipsmall.com Web: www.chipsmall.com

Address: A1208, Overseas Decoration Building, #122 Zhenhua RD., Futian, Shenzhen, China



# MQ303A Alcohol Sensor

## Character

- \* High sensitivity
- \* Fast response and resume
- \* Long life and low cost
- \* Mini Size

## Application

MQ303A is semiconductor sensor is for Alcohol detection, It has good sensitivity and fast response to alcohol, suitable for portable alcohol detector.

## Technical Data

Model No.		MQ303A	
Sensor Type		Semiconductor	
Standard Encapsulation		Metal	
Detection Gas		Alcohol	
Concentration		20-1000ppm Alcohol	
Standard Circuit Conditions	Heater Voltage	$V_H$	$0.9V \pm 0.1V$ AC or DC
	Loop Voltage	$V_e$	$\leq 6V$ DC
	Load Resistance	$R_L$	Adjustable
	Heater Resistance	$R_H$	$4.5\Omega \pm 0.5\Omega$ (Room Tem. )
	Heater Current	$I_H$	$120 \pm 20mA$
	Heater Power	$P_H$	$\leq 140$ mW
Character	Sensor Consumption	$P_S$	$\leq 10$ mW
	Sensing Resistance	$R_s$	$4K\Omega - 400K\Omega$ (in air)
	Sensitivity	$S$	$R_s(\text{in air})/R_s(125\text{ppm Alcohol}) \geq 3$
	Slope	$\alpha$	$0.50 \pm 0.15 (R_{300\text{ppm}}/R_{100\text{ppm Alcohol}})$
Condition	Tem. Humidity	$20^\circ\text{C} \pm 2^\circ\text{C}; 65\% \pm 5\%RH$	
	Standard test circuit	$V_c: 3.0 V \pm 0.1 V$ DC ; $V_H: 0.9 V \pm 0.1 V$ DC	
	Preheat time	Over 48 hours	



## Configuration

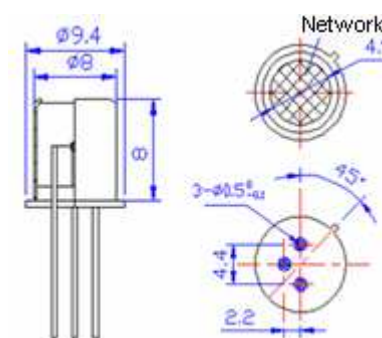
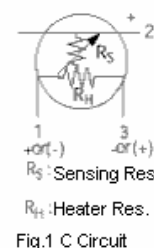
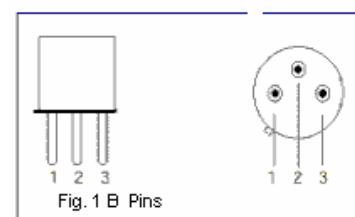
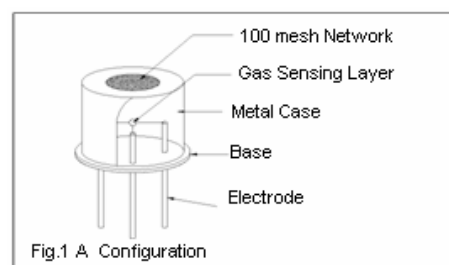

Sensing element of the semiconductor sensor is a micro-ball, heater and metal electrode are inside, and the sensing element is installed in anti-explosion double 100 mesh metal case (see the above)

## Sensitivity Characteristics

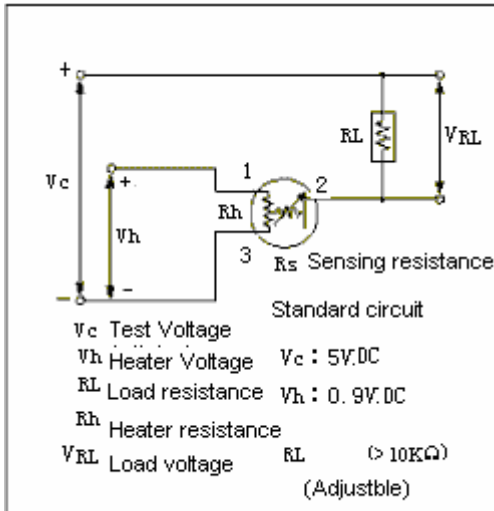

Fig 2 Standard Test Circuit

Fig.2 is the test circuit. You could get resistance change from voltage change on fixed or adjustable load resistance. Normally, it will take several minutes preheating for sensor enter into stable working after electrified; or you could give  $2.2 \pm 0.2V$  high voltage for 5-10secs before test, which make sensor easily stable.

## Influence of Temperature/Humidity

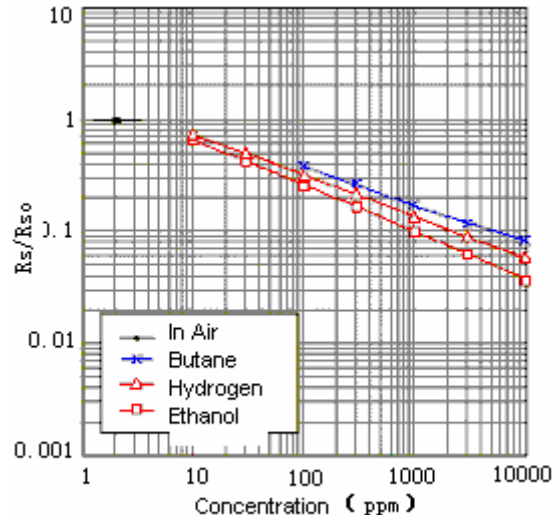

Fig 3 is sensitivity of MQ303A, it reflects relations between resistance and gas concentration, resistance of the sensor reduce when gas concentration increases

## Notification

### 1 Following conditions must be prohibited

#### 1.1 Exposed to organic silicon steam

Organic silicon steam cause sensors invalid, sensors must be avoid exposing to silicon bond, fixture, silicon latex, putty or plastic contain silicon environment

#### 1.2 High Corrosive gas

If the sensors exposed to high concentration corrosive gas (such as  $H_2S$ ,  $SO_x$ ,  $Cl_2$ ,  $HCl$  etc), it will not only result in corrosion of sensors structure, also it cause sincere sensitivity attenuation.

#### 1.3 Alkali, Alkali metals salt, halogen pollution

The sensors performance will be changed badly if sensors be sprayed polluted by alkali metals salt especially brine, or be exposed to halogen such as fluorin.

#### 1.4 Touch water

Sensitivity of the sensors will be reduced when spattered or dipped in water.

#### 1.5 Freezing

Do avoid icing on sensor's surface, otherwise sensor would lose sensitivity.

#### 1.6 Applied voltage higher

Applied voltage on sensor should not be higher than stipulated value, otherwise it cause down-line or heater damaged, and bring on sensors' sensitivity characteristic changed badly.

#### 1.7 Voltage on wrong pins

For 6 pins sensor, if apply voltage on 1、3 pins or 4、6 pins, it will make lead broken, and without signal when apply on 2、4 pins

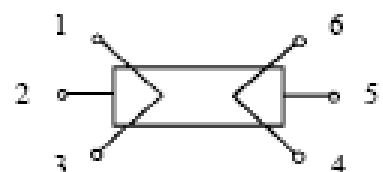

### 2 Following conditions must be avoided

#### 2.1 Water Condensation



---

Indoor conditions, slight water condensation will effect sensors performance lightly. However, if water condensation on sensors surface and keep a certain period, sensor' sensitivity will be decreased.

## 2.2 Used in high gas concentration

No matter the sensor is electrified or not, if long time placed in high gas concentration, it will affect sensors characteristic.

## 2.3 Long time storage

The sensors resistance produce reversible drift if it's stored for long time without electrify, this drift is related with storage conditions. Sensors should be stored in airproof without silicon gel bag with clean air. For the sensors with long time storage but no electrify, they need long aging time for stability before using.

## 2.4 Long time exposed to adverse environment

No matter the sensors electrified or not, if exposed to adverse environment for long time, such as high humidity, high temperature, or high pollution etc, it will effect the sensors performance badly.

## 2.5 Vibration

Continual vibration will result in sensors down-lead response then repute. In transportation or assembling line, pneumatic screwdriver/ultrasonic welding machine can lead this vibration.

## 2.6 Concussion

If sensors meet strong concussion, it may lead its lead wire disconnected.

## 2.7 Usage

For sensor, handmade welding is optimal way. If use wave crest welding should meet the following conditions:

2.7.1 Soldering flux: Rosin soldering flux contains least chlorine

2.7.2 Speed: 1-2 Meter/ Minute

2.7.3 Warm-up temperature:  $100\pm 20^{\circ}\text{C}$

2.7.4 Welding temperature:  $250\pm 10^{\circ}\text{C}$

2.7.5 1 time pass wave crest welding machine

If disobey the above using terms, sensors sensitivity will be reduced.