



Chipsmall Limited consists of a professional team with an average of over 10 year of expertise in the distribution of electronic components. Based in Hongkong, we have already established firm and mutual-benefit business relationships with customers from,Europe,America and south Asia,supplying obsolete and hard-to-find components to meet their specific needs.

With the principle of "Quality Parts,Customers Priority,Honest Operation,and Considerate Service",our business mainly focus on the distribution of electronic components. Line cards we deal with include Microchip,ALPS,ROHM,Xilinx,Pulse,ON,Everlight and Freescale. Main products comprise IC,Modules,Potentiometer,IC Socket,Relay,Connector.Our parts cover such applications as commercial,industrial, and automotives areas.

We are looking forward to setting up business relationship with you and hope to provide you with the best service and solution. Let us make a better world for our industry!



Contact us

Tel: +86-755-8981 8866 Fax: +86-755-8427 6832

Email & Skype: info@chipsmall.com Web: www.chipsmall.com

Address: A1208, Overseas Decoration Building, #122 Zhenhua RD., Futian, Shenzhen, China



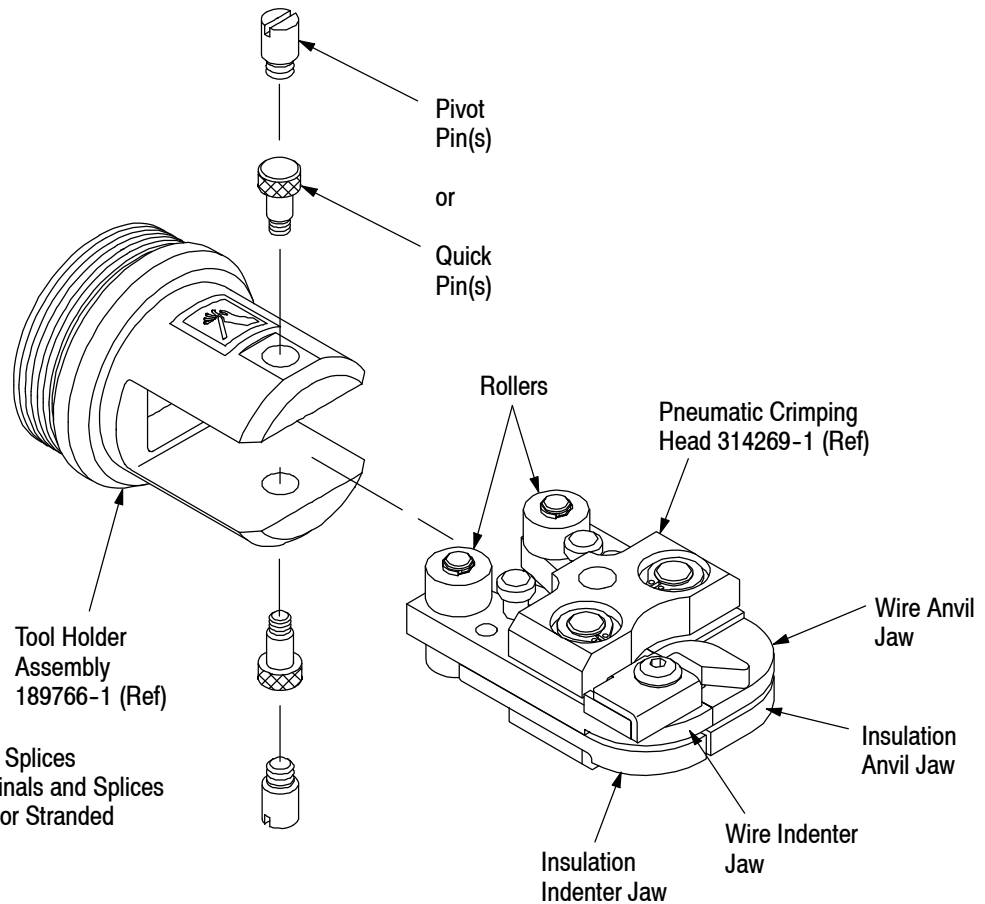

Product: PIDG* Terminals and Splices
 PLASTI-GRIP* Terminals and Splices
 Wire Size: 26-14 AWG, Solid or Stranded
 Product Catalog: 82042
 Tooling Catalog: 124208

Figure 1

1. INTRODUCTION

Pneumatic Crimping Heads 314269-1 (shown in Figure 1), 314270-1, 314270-3, 1213001-1, and 314537-1 are designed to crimp PIDG Terminals and Splices, and PLASTI-GRIP Terminals and Splices onto solid or stranded copper wire size 26-14 AWG. Refer to Figure 2. The crimping head is used with 626 Pneumatic Tooling Assemblies 189721-1, 189722-1, or 189724-1 fitted with Tool Holder Assembly 189766-1.

This instruction sheet provides recommended procedures for wire preparation, crimping head installation, crimping, and maintenance and inspection. For information concerning tool setup and operation, refer to Customer Manual 409-5862 packaged with the pneumatic tooling assembly.

NOTE
 The crimping heads can also be used with "2614" Series Pneumatic Tooling Assemblies.

NOTE
 Dimensions in this instruction sheet are in millimeters [with inch equivalents in brackets]. Figures and illustrations are for reference only and are not drawn to scale.

Reasons for reissue are provided in Section 8, REVISION SUMMARY.

NOTE
 Crimping Head 314270-1 is designed to crimp wires with 1.02-2.41 mm [.040-.095 in.] insulation diameter.

2. DESCRIPTION

The pneumatic crimping head consists of integral jaws which close in an arc-like motion. After an operator locates the terminal or splice between the crimping jaws and inserts the stripped wire, the tool is activated to crimp the terminal or splice to the wire.

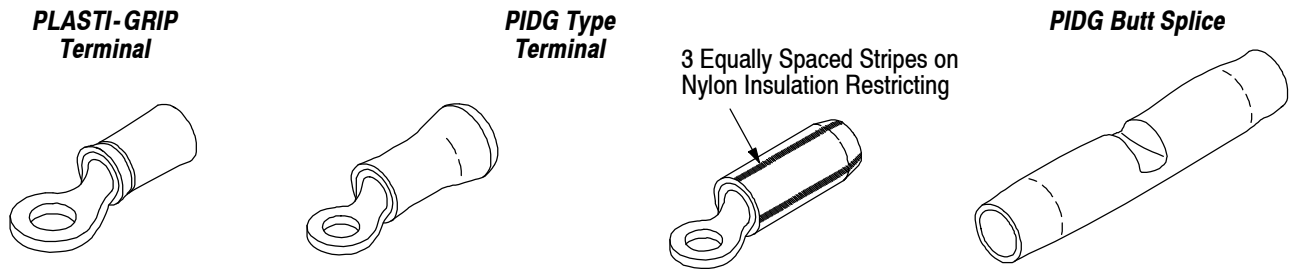

PRODUCT	CRIMPING HEAD	DOT CODE	WIRE RANGE (AWG)	TERMINAL/SPLICE INSULATION COLOR CODE	WIRE STRIP LENGTH (mm [IN.])			
					TERMINALS		SPLICES	
					MIN	MAX	MIN	MAX
PIDG TERMINALS AND SPLICES	314537-1	1 DOT	26-22	YELLOW	3.97 [.156]	4.78 [.188]	4.37 [.172]	5.16 [.203]
PIDG TERMINALS AND SPLICES AND PLASTI-GRIP TERMINALS	314270-1	1 DOT	22-18 (Aircraft)	RED	5.16 [.203]	5.94 [.234]	6.35 [.250]	7.14 [.281]
	314270-3	1 DOT	22-16 (Commercial)					
	314269-1	2 DOTS	16-14	BLUE				
PIDG SPLICES	1213001-1	1 DOT 1 RIB	22-18	RED				

NOTE: For PIDG terminals MS 25036-143 through -147 (Class 1 only), use 22-18 die.

PRODUCT	CRIMPING HEAD	DOT CODE	WIRE RANGE (AWG)	INSULATION DIAMETER RANGE (mm [IN.])	TERMINAL/SPLICE INSULATION COLOR CODE	WIRE STRIP LENGTH (mm [IN.])	
						MIN	MAX
PIDG NYLON INSULATION RESTRICTING TERMINALS	314537-1	1 DOT	26	0.66-1.40 [.026-.055]	YELLOW WITH BLACK STRIPE	6.35 [.250]	7.14 [.281]
			24	0.79-1.40 [.031-.055]	YELLOW WITH BLUE STRIPE		
	314270-1	1 DOT	22	0.97-2.41 [.038-.095]	RED WITH GREEN STRIPE		
			20	1.17-2.41 [.046-.095]	RED WITH RED STRIPE		
			18	1.42-2.41 [.056-.095]	RED WITH WHITE STRIPE		
			314270-3	1 DOT	24		
	22	0.97-2.79 [.038-.110]			RED WITH GREEN STRIPE		
	20	1.17-2.79 [.046-.110]			RED WITH RED STRIPE		
	18	1.42-2.79 [.056-.110]			RED WITH WHITE STRIPE		
	314269-1	2 DOTS	16	1.60-3.30 [.063-.130]	BLUE WITH BLUE STRIPE		
			14	1.98-3.30 [0.78-.130]	BLUE WITH GREEN STRIPE		

NOTE: For PIDG insulation restricting nylon terminals MS 7928/1-1 through -10, use 22-18 die.

NOTE: Refer to Catalog 82042 for product part numbers.

Figure 2

3. HEAD INSTALLATION AND REMOVAL

3.1. Head Selection

The crimping heads are color-coded to match the terminal and splice insulation color. Observe the embossed dots on the insulation of finished crimps to ensure that the correct combination of terminal or splice and head was used. See Figure 2.

NOTE
 Crimping heads are coated with a preservative to prevent rust and corrosion. Wipe this preservative from the head, particularly from the crimping surfaces.

3.2. Installation

DANGER
 To avoid personal injury, ALWAYS disconnect pneumatic tool from air supply before installing or removing the crimping head.

DANGER
 DO NOT operate pneumatic tool without the proper crimping head installed. After crimping head is installed, make sure that the quick pins or pivot pins are FULLY tightened to avoid personal injury and damage to the tool.

1. Remove quick pins from tool holder. Refer to Figure 1.
2. Insert crimping head into tool holder as shown in Figure 1.
3. After crimping head is properly aligned, insert and tighten quick pins (provided with tool holder assembly) or pivot pins (provided with crimping head). See Figure 1.

NOTE
 Tyco Electronics recommends using LOCTITE 242 removable threadlock, or equivalent, to prevent the quick pins or pivot pins from loosening.

4. Connect pneumatic tool to an adequate air supply between 620–690 kPa [90–100 psi]. For specific information on air line requirements and air hose installation, refer to the customer manual packaged with the pneumatic tooling assembly.

3.3. Removal

DANGER
 To avoid personal injury, ALWAYS disconnect pneumatic tool from air supply before removing crimping head.

Remove quick pins or pivot pins from crimping head; then remove crimping head from tool holder.

4. HEAD INSTALLATION AND REMOVAL

DANGER
 To avoid personal injury, ALWAYS keep fingers clear of crimping jaws when operating the tool. Never place anything within the crimping jaws except terminals or splices.

4.1. Terminal Crimping Procedure

1. Strip wire to dimensions shown in Figure 2. DO NOT nick wire strand or use wires with nicked or missing conductor strands.
2. Open crimping jaws by squeezing rollers together simultaneously; then position terminal between crimping jaws, as shown in Figure 3. The terminal is properly positioned when the tongue of the terminal is under the locator and the wire barrel is against the locator.
3. After terminal is properly positioned in crimping jaws, release rollers to allow crimping jaws to spring shut, holding terminal in place.
4. Insert stripped wire into terminal until the end of the conductor butts against the locator.

PIDG and PLASTI-GRIP Terminals

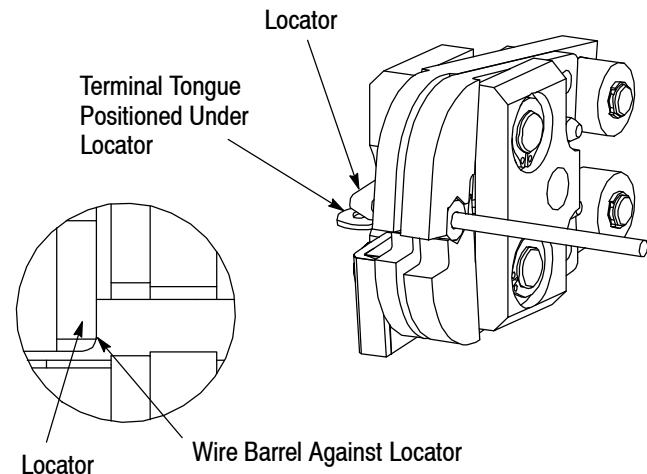
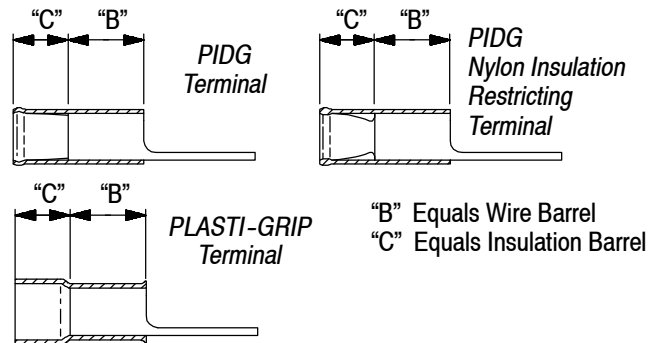

Figure 3

5. Activate the tool to complete the crimp. Open crimping jaws by squeezing the rollers together simultaneously; then remove crimped terminal.
6. Refer to Section 5 and Figure 6 for crimp inspection.

4.2. Butt Splice Crimping Procedure

1. Strip wire to dimensions shown in Figure 2. DO NOT nick wire strand or use wires with nicked or missing conductor strands.
2. Open crimping jaws by squeezing rollers together simultaneously. Position splice between crimping jaws so that the window indent slides under the locator of crimp head. See Figure 4.A.
3. After splice is properly positioned in crimping jaws, release rollers to allow crimping jaws to spring shut, holding splice in place.
4. Insert stripped wire into wire barrel of splice until the end of the conductor is against the splice wire stop. See Figure 4.A.
5. Activate tool to complete the crimp. Open crimping jaws by squeezing rollers together simultaneously; then remove crimped splice.
6. To crimp the other half of the butt splice, reposition it in the crimping jaws and repeat Steps 1 through 5. If the splice cannot be turned, rotate crimping head. See Figure 4.B.
7. Refer to Section 5 and Figure 6 for crimp inspection.

4.3. Insulation Crimp Adjustment

A. PIDG Terminals and Splices

NOTE *PIDG terminals and splices contain a wire insulation "grip".*

The insulation crimping section of the crimping head has three positions: 1—Tight; 2—Medium; and 3—Loose.

1. Insert insulation adjustment pins in Position 3. See Figure 5.

NOTE *Always place both adjustment pins in the same position. See Figure 5.*

2. Place terminal or splice in crimping jaws, as shown in Figures 3 and 4.
3. Insert **unstripped** wire **only into the insulation barrel** of the terminal or splice. See Figures 3 and 4.

4. Crimp terminal or splice as described in Paragraph 4.1 or 4.2.

5. Remove terminal or splice. Bend wire forward and then backward. The terminal or splice should retain its grip on the wire. If the wire pulls out, reposition the insulation adjustment pins in the next tighter position and repeat crimping procedure.

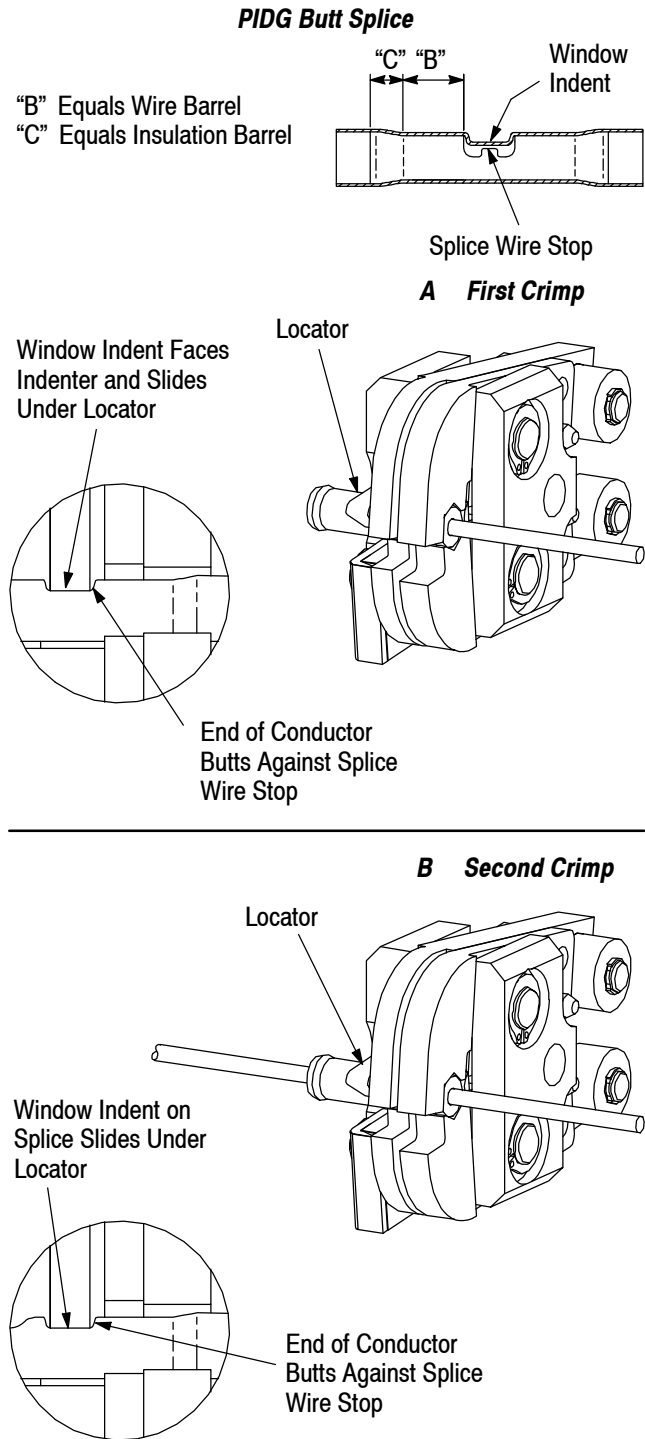

Figure 4

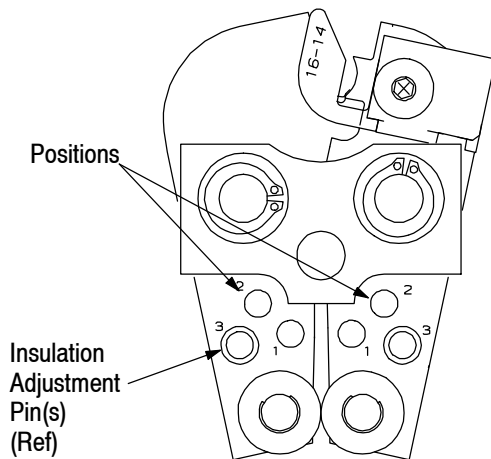

Figure 5

6. Repeat adjustment as necessary until desired insulation grip is obtained. DO NOT use a tighter setting than required.

B. PLASTI-GRIP Terminals

NOTE



PLASTI-GRIP terminals contain only a wire insulation "support".

The insulation crimping section of the crimping head has three positions: 1—Tight; 2—Medium; and 3—Loose.

Position 3 is for wire having a large insulation diameter; Position 2 is for wire having a medium insulation diameter; and Position 1 is for wire having a small insulation diameter.

1. Perform insulation crimp adjustment by placing adjustment pins in Position 3 (loose), as shown in Figure 5.
2. Crimp the terminal as described in Paragraph 4.1, Terminal Crimping Procedure.
3. Remove crimped terminal from crimping jaws and visually inspect the insulation barrel crimp of the terminal. The insulation barrel crimp should be in contact with and should support the wire insulation.

If the insulation barrel crimp does not provide "support" for wire insulation, place adjustment pins in Position 2 (medium) and repeat the crimp procedure.

4. Repeat adjustment as necessary until desired insulation support is obtained. DO NOT use a tighter setting than required.

5. CRIMP INSPECTION

Inspect crimped terminals and splices by checking the features described in Figure 6. Use only terminals or

splices that meet the conditions shown in the "ACCEPT" column. "REJECT" terminations can be avoided through careful use of instructions in Section 4, and by performing regular head maintenance, as described in Section 6.

6. MAINTENANCE AND INSPECTION

DANGER



To avoid personal injury, ALWAYS disconnect air supply from pneumatic tool before performing maintenance or inspection.

Tyco Electronics recommends that a maintenance and inspection program be performed periodically to ensure dependable and uniform terminations. The pneumatic crimping head should be inspected once a month. Frequency of inspection should be adjusted to suit your requirements through experience. Frequency of inspection depends on:

1. The care, amount of use, and handling of the crimping head.
2. The type and size of the product crimped.
3. The degree of operator skill.
4. The presence of abnormal amounts of dust and dirt.
5. Your own established standards.

Each crimping head is thoroughly inspected before packaging. Since there is the possibility of crimping head damage during shipment, new crimping heads should be inspected immediately upon arrival at your facility.

6.1. Daily Maintenance

Tyco Electronics recommends that each operator be responsible for the following steps of daily maintenance:

1. Remove dust, moisture, and other contaminants with a clean, soft brush, or a lint-free cloth. Do NOT use objects that could damage the head.
2. Make sure that all pins, rings, and other components are in place and secure.

DANGER



To avoid personal injury and damage to the tool, make sure quick pins or pivot pins are fully tightened.

3. Make certain all surfaces are protected with a thin coat of any good SAE 20 motor oil. Do NOT oil excessively.
4. When the head assembly is not in use, store it in a clean dry, area.

Crimp Inspection

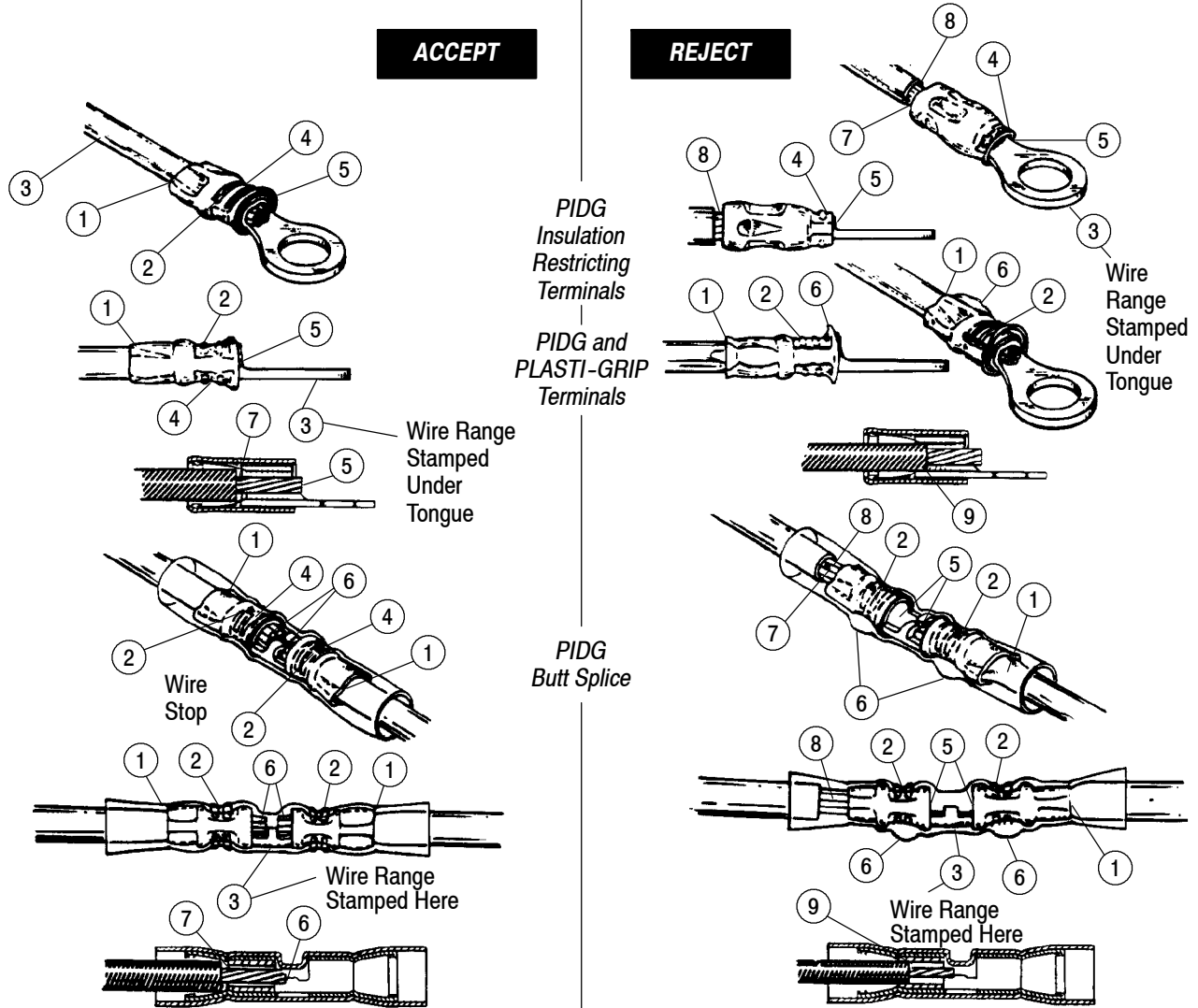

- ① Insulation barrel is in firm contact with wire insulation.
- ② Correct color code, dot code, and tool combination.
- ③ Wire size is within wire range stamped on terminal tongue or splice.
- ④ Crimp centered on wire barrel.
- ⑤ End of conductor is flush with, or extends beyond end of terminal wire barrel.
- ⑥ End of conductor against wire stop of splice.
NOTE: If conductor is not against wire stop, conductor must at least be flush with, or extend slightly beyond wire barrel of splice.
- ⑦ Wire insulation does not enter wire barrel.

- ① Wire insulation extruded. (Insulation crimp too tight on PIDG terminals.) See Paragraph 4.3.
- ② Wrong dot code and color code combination. See chart, Figure 2.
- ③ Wire size is not within wire range stamped on terminal tongue or splice.
- ④ Crimp not centered on wire barrel. (Terminal was not butted against locator. See Figure 3.)
- ⑤ End of conductor is not flush with or extending beyond end of wire barrel. (Check for correct strip length.)
- ⑥ Excessive flash or extruded insulation. (Wrong tool, terminal, or splice combination used, or damaged dies.) See Figure 2.
- ⑦ Nicked or missing conductor strands.
- ⑧ Wire not fully inserted or wrong strip length.
- ⑨ Wire insulation entered wire barrel. Check for correct wire size or strip length.

Figure 6

6.2. Periodic Inspection

Regular inspections should be performed by quality control personnel. A record of scheduled inspections should remain with the crimping heads or be supplied to supervisory personnel responsible for the crimping heads. Though recommendations call for at least one inspection a month, the frequency should be based on amount of use, working conditions, operator training and skill, and your established company policies. These inspections should include a visual inspection (Paragraph 6.3) and a crimping chamber inspection (Paragraph 6.5).

6.3. Visual Inspection

1. Remove all lubrication and accumulated film by immersing the crimping head in a suitable commercial degreaser that will not affect paint or plastic.
2. Make certain all components are in place. If replacements are necessary, refer to Figure 10.
3. Check all bearing surfaces for wear. Make sure the rollers turn freely with minimal resistance. Replace worn parts.
4. Inspect crimp area for flattened, chipped, or broken areas. See Figure 7. Replace worn or damaged parts.

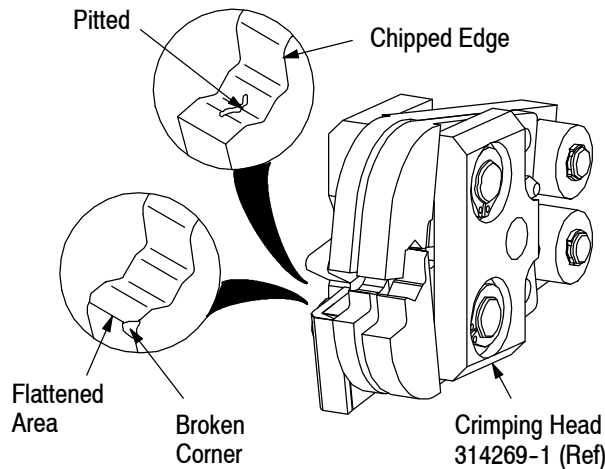

Figure 7

Lubricate all pins, pivot points, and bearing surfaces with a high quality grease. Tyco Electronics recommends the use of Molykote grease, which is a commercially available lubricant. Lubricate according to the following schedule:

- Head used in daily production - lubricate daily
- Head used daily (occasional) - lubricate weekly
- Head used weekly - lubricate monthly

Wipe excess grease from crimping head, particularly from jaw closure areas. Grease transferred from jaw closure area onto certain terminations may affect the electrical characteristics of an application.

6.4. Gaging the Crimping Chamber

This inspection requires the use of plug gages conforming to the dimensions shown in Figure 8. Tyco Electronics does not manufacture or market these gages.

Suggested Plug Gage Design Wire Barrel Crimp

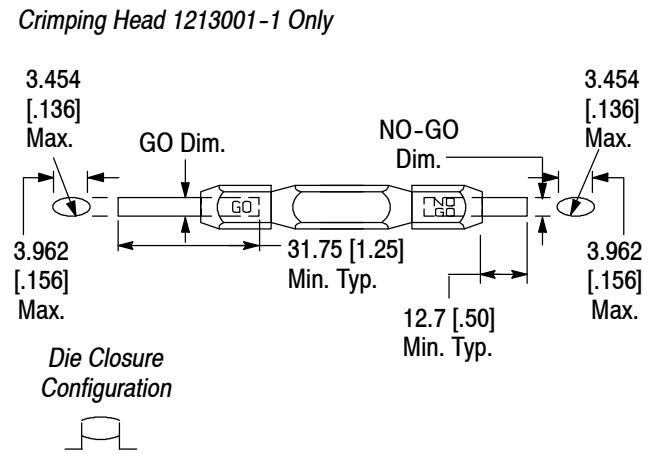
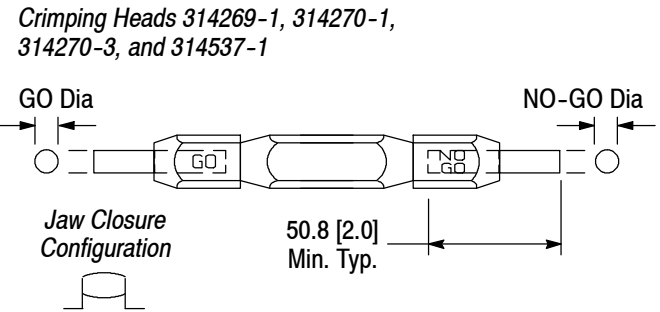

CRIMPING HEAD	JAW CLOSURE DIMENSIONS (mm [IN.])	GAGE ELEMENT DIAMETERS (mm [IN.])	
		GO	NO-GO
314270-1	2.769-2.921	2.769-2.776	2.918-2.921
314270-3	[.1090-.1150]	[.1090-.1093]	[.1149-.1150]
314269-1	3.023-3.175	3.023-3.030	3.172-3.175
	[.1190-.1250]	[.1190-.1193]	[.1249-.1250]
314537-1	1.600-1.752	1.600-1.608	1.750-1.752
	[.0630-.0690]	[.0630-.0633]	[.0689-.0690]
1213001-1	2.616-2.718	2.616-2.624	2.715-2.718
	[.1030-.1070]	[.1030-.1033]	[.1069-.1070]

Figure 8 (cont'd)

Suggested Plug Gage Design Insulation Crimp

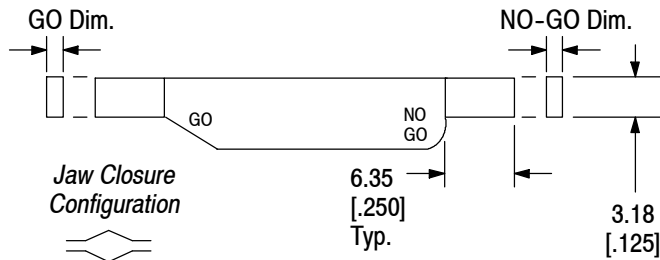

CRIMPING HEAD	JAW CLOSURE DIMENSIONS (mm [IN.])	GAGE ELEMENT DIAMETERS (mm [IN.])	
		GO	NO-GO
314270-1	0.965-1.473 [.0380-.0580]	0.965-0.973 [.0380-.0383]	1.471-1.473 [.0579-.0580]
314270-3	0.762-1.270 [.0300-.0500]	0.762-0.770 [.0300-.0303]	1.267-1.270 [.0499-.0500]
314269-1	1.016-1.524 [.0400-.0600]	1.016-1.024 [.0400-.0403]	1.521-1.524 [.0599-.0600]
314537-1	0.762-1.270 [.0300-.0500]	0.762-0.770 [.0300-.0303]	1.267-1.270 [.0499-.0500]
1213001-1	0.762-1.270 [.0300-.0500]	0.762-0.770 [.0300-.0303]	1.267-1.270 [.0499-.0500]

Figure 8 (end)



Disconnect air supply and remove crimping head from tool before inspecting crimping chambers.

1. Remove oil and dirt from the jaw bottoming surfaces and plug gage element surfaces.
2. Close wire barrel crimping jaws until they are bottomed, but not under pressure.
3. Align GO element with wire barrel crimping section. Push element straight into crimping chamber without using force. The GO element must pass completely through the chamber as shown in Figure 9.A.

4. Align the NO-GO element and try to insert it into the chamber. The element may start entry, but it must not pass completely through the crimping chamber.

5. Repeat this procedure for the insulation crimping section using a plug gage as shown in Figure 9.B.

If the crimping chamber passes the gage inspection, the crimping head is considered dimensionally correct and should be lubricated with a THIN coat of any good SAE 20 motor oil. If the crimping chamber does not conform to the plug gage conditions, contact your local Tyco Electronics Representative or refer to Section 7, REPLACEMENT AND REPAIR.

For additional information about the use of a plug gage, see Instruction Sheet 408-7424.

7. REPLACEMENT AND REPAIR

Replacement parts and recommended spares are listed in Figure 10. The recommended spares should be stocked for immediate replacement.

Order replacement parts through your Tyco Electronics Representative, or call 1-800-526-5142, or send a facsimile of your purchase order to 1-717-986-7605, or write to:

CUSTOMER SERVICE (38-35)
 TYCO ELECTRONICS CORPORATION
 PO BOX 3608
 HARRISBURG PA 17105-3608

For further repair and replacement information, call the Tooling Assistance Center number at the bottom of page 1.

8. REVISION SUMMARY

Since the previous release of this sheet, the following changes were made:

- Added "Original Instructions"

Detail A
Inspection of Wire Barrel
Crimping Section

Detail B
Inspection of Insulation
Crimping Section

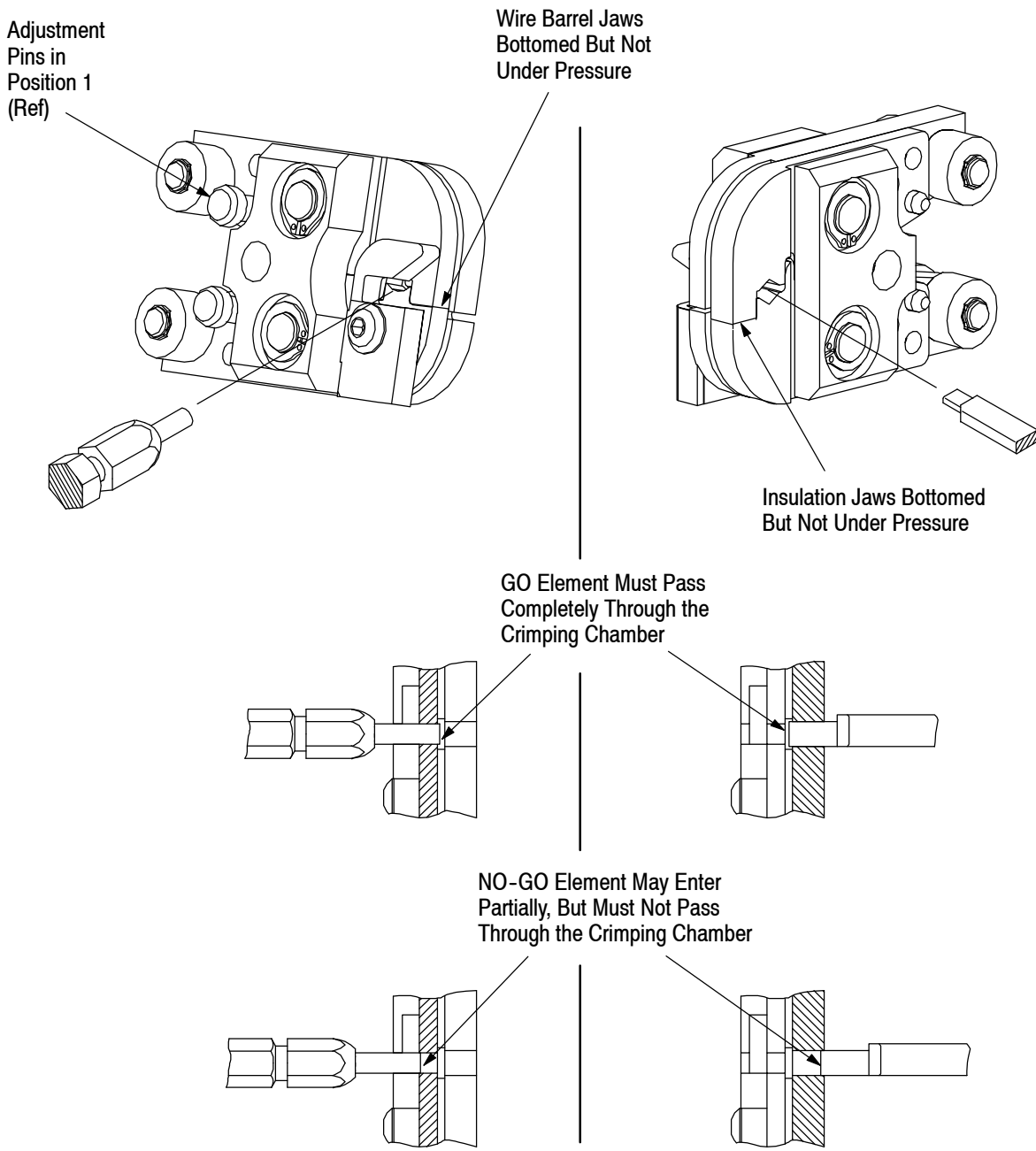
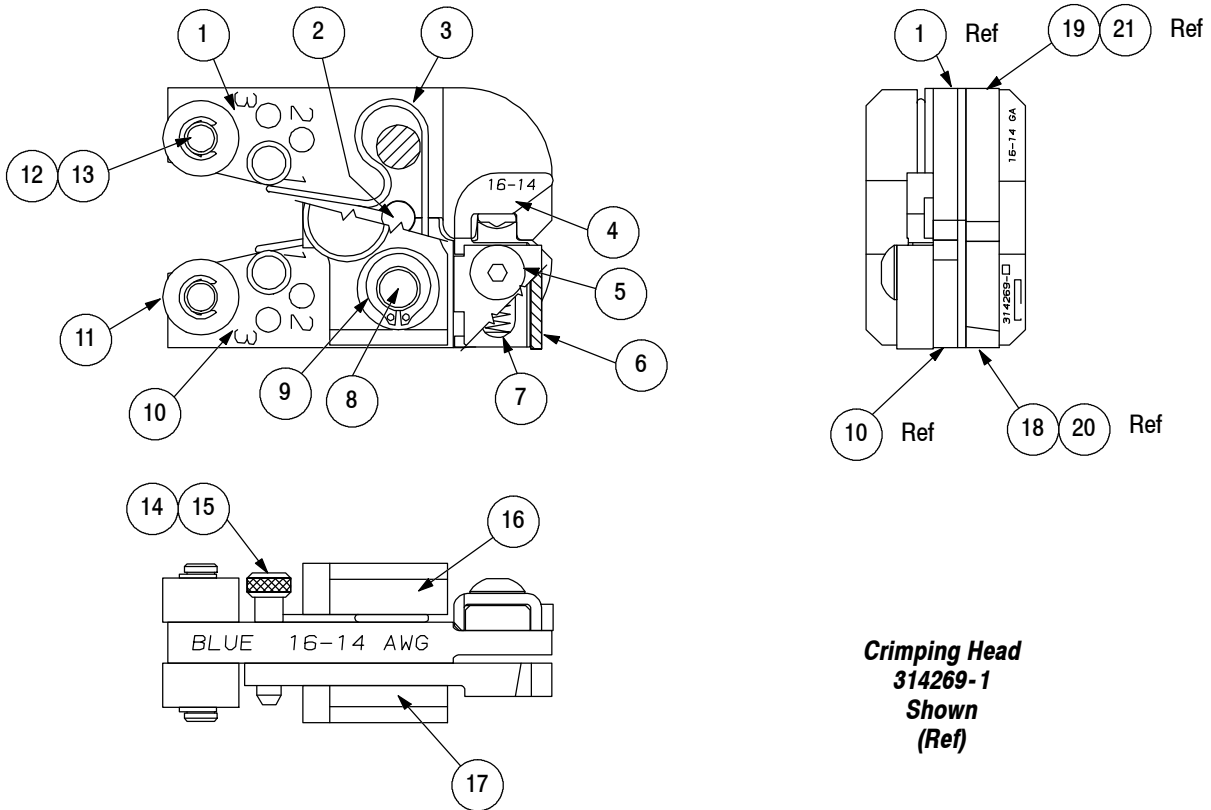

Figure 9



**Crimping Head
314269-1
Shown
(Ref)**

CUSTOMER REPLACEMENT PARTS

ITEM NO.	PART NO. FOR CRIMPING HEAD				DESCRIPTION	QTY PER HEAD
	314269-1	314270-1, -3	314537-1	1213001-1		
1	314560-1	314560-2	314560-3	1-306064-4	INDENTER	1
2	39085	39085	39085	39085	PIN, Pivot	1
3	314253-1	314253-1	314253-1	314253-1	SPRING	1
4	45965-6	302993	3-304052-6	4-304052-6	LOCATOR	1
5	9-305927-1	9-305927-1	3-306105-9	9-305927-1	SCREW, 8-32 x .33	1
6	302994	302994	302994	302994-1	HOUSING, Stop	1
7	301201	301201	301201	301201	SPRING, Compression	1
8	3-23628-4	3-23628-4	3-23628-4	3-23628-4	PIN, Str, Grv .2500 Dia	2
9	21048-7	21048-7	21048-7	21048-7	RING, Retaining	4
10	314561-1	314561-2	314561-3	1-306063-4	ANVIL	1
11	314479-1	314479-1	314479-1	314479-1	ROLLER	4
12	3-23619-7	3-23619-7	3-23619-7	3-23619-7	PIN, Str, Grv .1875 Dia	2
13	21045-3	21045-3	21045-3	21045-3	RING, Retaining	4
14	39208	39208	39208	39208	RING	6
15	39207	39207	39207	39207	PIN, Adjustment	2
16	314477-1	314477-1	314477-1	314477-1	LINK	1
17	314477-2	314477-2	314477-2	314477-2	LINK	1
18	314563-1	314563-2◆	314563-3	1-306065-5	ANVIL, Insulation	1
19	314562-1	314562-2◆	314562-3	1-306066-5	INDENTER, Insulation	1
20	—	314563-4■	—	—	ANVIL, Insulation	1
21	—	314562-4■	—	—	INDENTER, Insulation	1

◆ For Crimping Head 314270-3 only.
■ For Crimping Head 314270-1 only.

Figure 10