



Chipsmall Limited consists of a professional team with an average of over 10 year of expertise in the distribution of electronic components. Based in Hongkong, we have already established firm and mutual-benefit business relationships with customers from,Europe,America and south Asia,supplying obsolete and hard-to-find components to meet their specific needs.

With the principle of "Quality Parts,Customers Priority,Honest Operation,and Considerate Service",our business mainly focus on the distribution of electronic components. Line cards we deal with include Microchip,ALPS,ROHM,Xilinx,Pulse,ON,Everlight and Freescale. Main products comprise IC,Modules,Potentiometer,IC Socket,Relay,Connector.Our parts cover such applications as commercial,industrial, and automotives areas.

We are looking forward to setting up business relationship with you and hope to provide you with the best service and solution. Let us make a better world for our industry!



Contact us

Tel: +86-755-8981 8866 Fax: +86-755-8427 6832

Email & Skype: info@chipsmall.com Web: www.chipsmall.com

Address: A1208, Overseas Decoration Building, #122 Zhenhua RD., Futian, Shenzhen, China



RS-05B type tipping bucket rain gauge user's Guide

Issue:. V1 0



1.1 Product Overview.....	3
1.2 Construction features.....	3
1.3 Main Specifications.....	4
2. Installation instructions for the equipment.....	4
2.1 Equipment installation check.....	4
Indoor installation and commissioning of equipment 2.2.....	5
2.2.1 mounting base support legs.....	5
2.2.2 Install the tipping bucket.....	5
2.2.3 hoist mounting bracket.....	8
2.2.4 level adjustment bracket.....	8
2.2.5 Check the instrument output signal is normal.....	8
2.3 Outdoor installation.....	9
2.3.1 Outdoor ground and roof installation.....	9
4. Maintenance and maintenance.....	12
5. Frequently Asked Questions and Solutions.....	13
5. Equipment packing list.....	14

1. Product introduction

1.1 Product Overview

The instrument is an instrument measuring rainfall, its performance national standard GB / T11832-2002 "tipping bucket rain gauge" requirement.

The core components of the instrument tipped with a three-dimensional streamlined design, so that the tipping of the water more smooth, and has a self-cleaning dust, easy to clean the function.

1.2 Construction features

As shown in Figure 1, the instrument consists of the bearing port 1, the filter 2, the water diversion hopper 3, the tumbler bracket 4, the tipping bucket 5, the tumbler sleeve 6, the angle adjusting device 7, the horizontal adjusting device 8, the constant magnetic steel 9, A reed tube 10, a signal output terminal 11, a drain funnel 12, a base 13, a stainless steel cylinder body 14, a base support pin 15, and the like. Among them, the bucket bracket 4 is provided with a dome sleeve 6 and a round horizontal bubble, a reed holder and a signal output terminal.

Unlike other tipping bucket gauges, the instrument's tumbler sleeve is an integrated rotary positioning structure. The tipping bucket 5 is mounted in a two-axle gemstone bearing through a tipping shaft to make the tipping and disassembly easier and less Adjust the distance between the two bushings, to the site to bring a convenient installation.

The instrument of the dump truck for the three-dimensional streamlined design, and design a sagging arc diversion tip, its beautiful shape smooth, better performance and easy to clean water maintenance.

The instrument's diversion funnel and tipping bracket for the tight fit to install, under normal circumstances do not have to remove the water diversion funnel.

The instrument of the waterway channel components diversion funnel, dump bucket and drainage funnel with imported high-quality transparent material production, the instrument dynamic work process observation more clearly.

The instrument is equipped with two constant magnetic steel on the dump, the reed tube bracket is equipped with two reed, the instrument factory and the reed steel have been adjusted at the appropriate coupling distance, the instrument output signal and tumbling flip The number of times have a certain proportion of the relationship. Instrument two-way signal output in the way for the field count measurement, the other way for telegraphic telegram. The instrument and the telemetry terminal connected, should be equipped with a matching interface circuit to prevent the jeep jitter due to reed and jump due to jump caused by the count, reported errors.

The instrument has been dumped at the end of the dump angle adjustment screw lock in the best tilt point of the base position and the tilt screw made a little red paint treatment, the user on-site installation of the instrument only in accordance with the requirements of this manual will be installed in the dump truck. The two bushings on the bracket and the level of the dome to adjust the level of the bubble in the center position can be put into use, do not have to adjust the dumping angle.

1.3 Main Specifications

Rain bearing diameter: $\varnothing 200_{\pm 0.060}$ mm; edge at an acute angle: $40^{\circ} \sim 45^{\circ}$

Resolution: 0.5mm;

Measurement accuracy: $\leq \pm 2\%$ (indoor artificial precipitation, the instrument itself to the amount of discharge)

Rain intensity range: 0.01mm \sim 4mm / min (allowed through the maximum rain intensity 8mm / min)

Send mode: double contact on-off signal output
working environment:

Ambient temperature: 0 \sim 50 $^{\circ}\text{C}$

Relative humidity: $< 95\%$ (40 $^{\circ}\text{C}$)

Weight Size: $\varnothing 216 \times 350$ 2Kg

2. Installation instructions for the equipment

2.1 Equipment installation check

(1) remove the instrument from the box, check the packing list with the instructions carefully, check the equipment accessories are complete;

(2) carefully read the product manual, check delivery inspection records, product certification;

(3) check the appearance of the instrument is damaged, in particular, check the tipping bucket is intact, and pay attention to properly put a good dump, to prevent the tipping axis of the shaft and the end of the bucket at both ends of the arc-shaped water tip, and do not touch the door with the fingers, Avoid fouling tipping to damage instrument accuracy.

Indoor installation and commissioning of equipment 2.2

2.2.1 mounting base support legs

As shown in Figure 1, remove the instrument barrel, the three stainless steel support legs were used with two M4 × 20 stainless steel countersunk head screws, flat washers, nuts installed in the circular base on the corresponding installation position, and forced tight Screw nut, to prevent loosening, and then the overall level of the instrument movement on the desktop.

2.2.2 Install the tipping bucket

a Control the two dome lock nuts N1, N2, N3 and 3 manually raise the nuts M1, M2, M3 on the dome bracket to rotate in the counterclockwise direction and remove the nuts N1, N2, N3. , And then the bucket bracket together with the water diversion funnel from the three adjustable horizontal support bolts L1, L2, L3 vertical up and out, and the bracket horizontally placed on the desktop;

Note: Do not rotate the three manually raised nuts M1, M2, M3 when doing the above.

b In contrast to Figure 3, replace the handle with the right side sleeve by 90 degrees, and gently pull the right sleeve from the sleeve mounting hole on the bracket. Has been inlaid with precious stones bearing;

c, as shown in Figure 3, with the left hand to get the bucket, so that the two magnetic steel on the bucket on the bracket 4 on the reed tube, gently put the tread placed in the center of the stent 4, so that the fork tip at the left Of the gemstone bearing hole, gently insert the shaft tip into the gemstone bearing hole, and then the right axis of the bucket shaft is aligned with the center position of the right mounting hole of the bucket bracket, and the right sleeve is removed from the right hand with the right hand Hole, until the right axis of the bucket into the gemstone bearing hole after the right sleeve of the handle down 90 degrees, so that the handle on the circular bulge into the handle positioning hole, the bucket is installed. Install the tipping bucket should be able to

flexibly turn, this time between the bucket shaft and the two sleeve between the swimming gap is about 0.3mm.

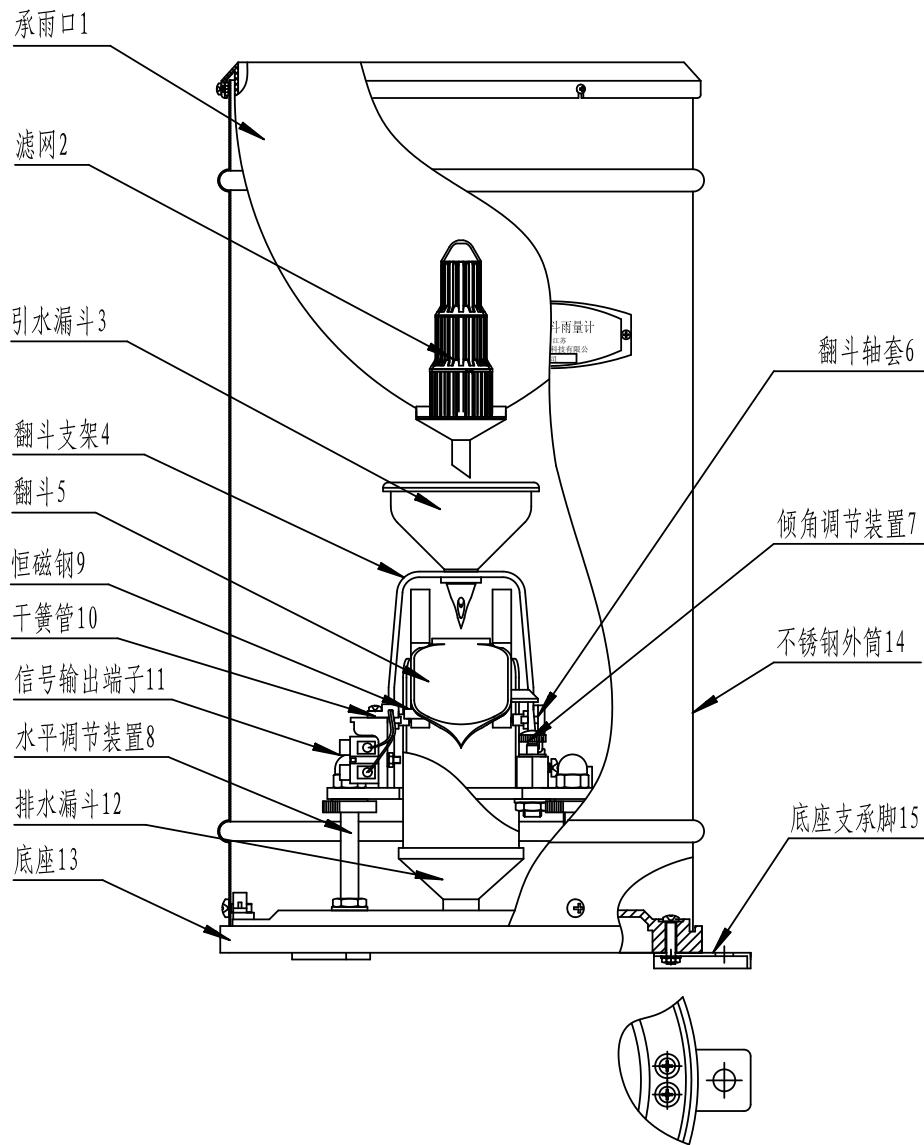

Figure 1

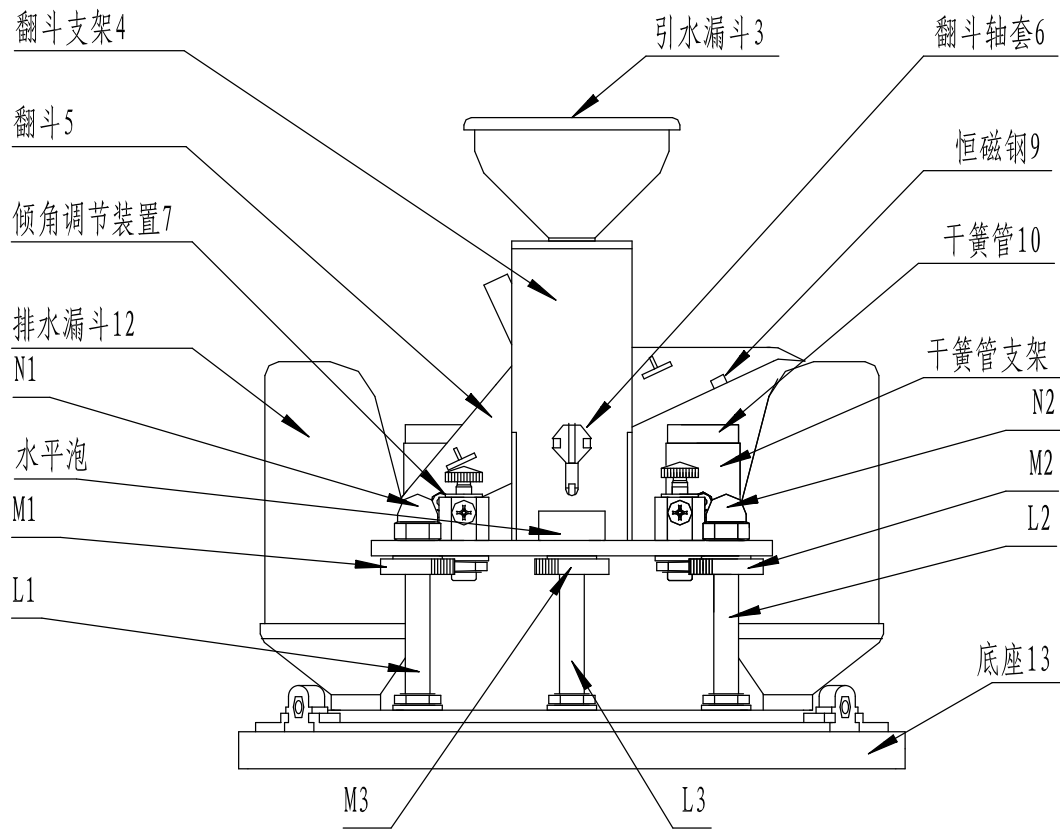

Figure 2

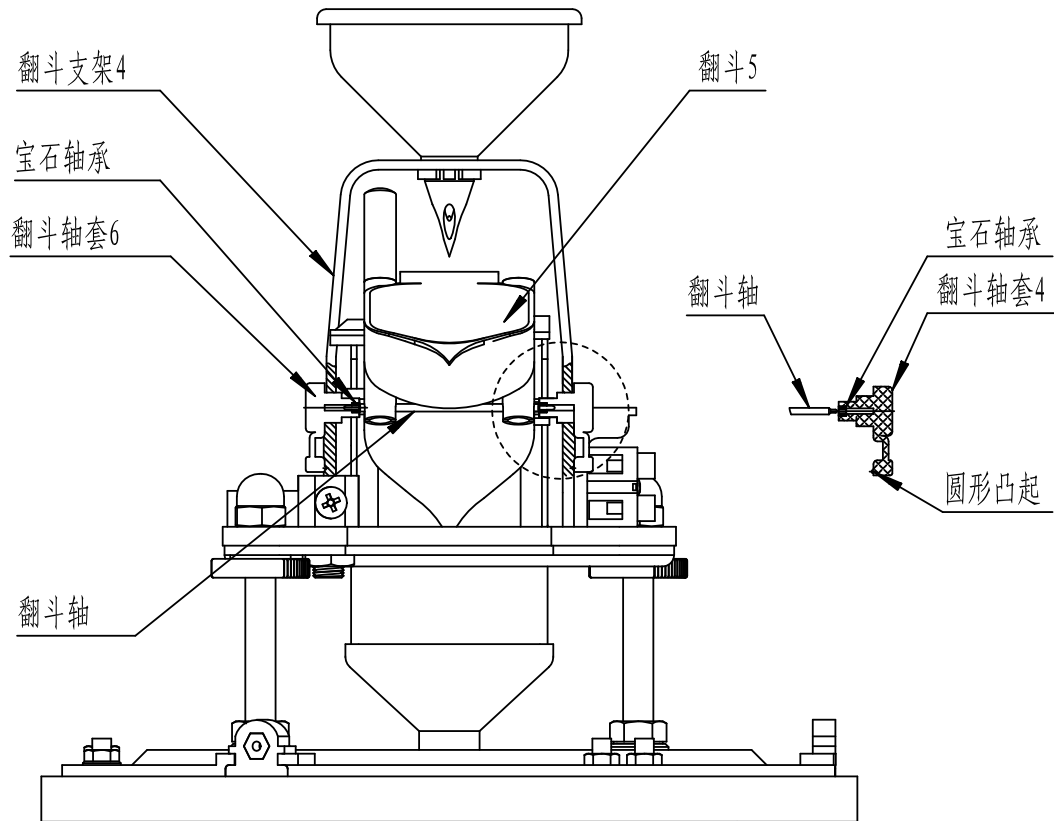

Figure 3

2.2.3 hoist mounting bracket

The hoist has been installed in the carrier with a funnel mounted opposite to the dump step 4.2.2 re-approach the support bracket mounting bolts L1, L2, L3, raised against the planar lower holder nut M1, M2, M3, Then the top part of the three support bolts should be exposed on the plane of the bracket 4 about 4 ~ 5mm height, and then the three dome nuts N1, N2, N3 re-installed in the support bolts L1, L2, L3, and do not lock Each dome nut.

2.2.4 level adjustment bracket

If the dome nut N1, N2, N3 are kept in the unlocked state, do not adjust the height of the height of the nut M3, just adjust the height of the nuts M1 and M2 with two hands, The bubble can be in the center position, and then lock the dome nut N1, N2, N3, again observe the level of bubble can be centered.

2.2.5 Check the instrument output signal is normal

Check the method: the multimeter with the Ω gear in turn connected to the output of the two output terminals and gently flip the tipping of the hand, check the instrument output is normal. The product is shipped from the factory to adjust the reed switch to the best coupling position (at this time the reed switch and the distance between the two constant magnetic steel is about $2 \pm 0.5\text{mm}$), if the output is not normal, should check the reed Whether the connection is good or whether the connection point is reliable or re-adjust the relative position between the reed switch and the magnet, the problem can be solved.

2.3 Outdoor installation

2 3.1 Outdoor ground and roof installation

a production basis

As shown in Figure 4: outdoor ground and roof installation, should be in accordance with the size and requirements of Figure 4 to prepare cement installation foundation, cement foundation should be horizontal level. The size of the cement installation foundation is generally a 40 cm x 40 cm square base with a height of not less than 30 cm or a circular base with a diameter of 40 cm. The height of the bearing capacity of the instrument is 70cm away from the ground plane, and the shelter of the instrument is not allowed within 3 to 5 meters of the instrument mouth.

b Install the fixed instrument to adjust the level of the bearing port

According to the size of Figure 4 in the cement on the basis of three $\phi 12$ deep 8 ~ 10cm mounting holes, the expansion bolt placed in the mounting hole, with the lock nut lock, and then the instrument base installed in the three adjustable support nut, By adjusting the height of the support nut and measuring the level of the ring with a horizontal scale is in the horizontal state, and finally with the lock on the instrument fixed;

c Adjust the level of the bucket bracket

Remove the outer stainless steel tube, to check and adjust the level of the dump cradle foam bubbles whether living intermediate position according to the present specification, process steps 2 .2.4 again;

d Install the output signal cable

One end of the output signal line is connected with the corresponding output terminal, and the other end of the output signal line is connected with the upper data collecting device through the buried protection pipe through the grounding hole of the instrument base, and the sealing hole

is sealed and installed with the sealant Instrument stainless steel outer cylinder and locking outer cylinder locking screw.

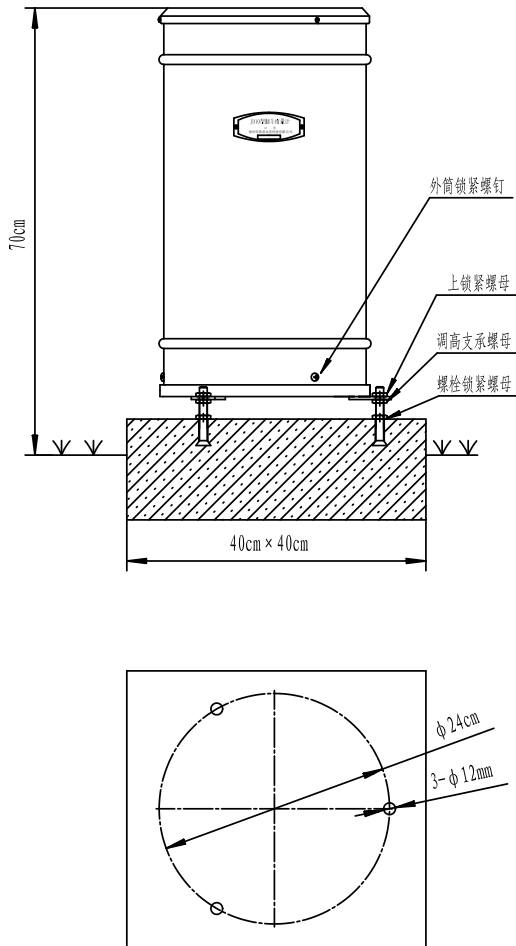

Figure 4

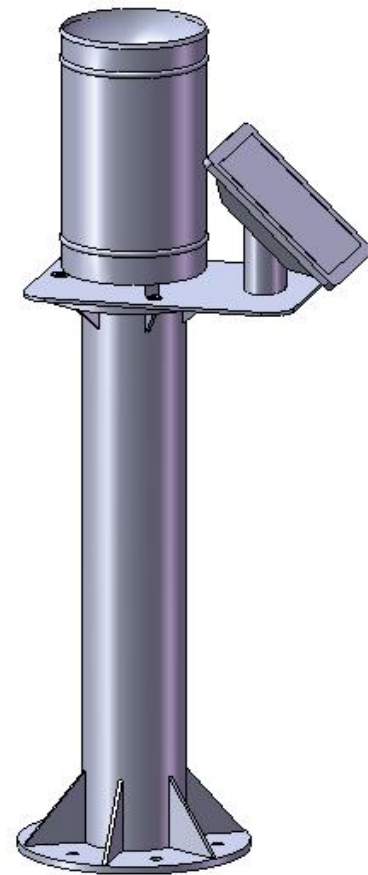

Figure 5

2.3.2 outdoor pole mounting

As shown in Fig. 5, when the outdoor rod is installed, the height of the height of the instrument is 2m from the ground plane, and the tilting bracket and the bearing port must be adjusted to the horizontal position. Compared with the ground installation, rod-mounted base is not a cement base but a dedicated support rod. Installation as long as the instrument base with the installation bolts and support rod flange can be firmly connected. Rod-mounted dowel brackets are adjustable in level, and the method of adjusting the level of the mouthpiece is the same as that of the ground installation method.

Installation 2.3.3 telemetry station rainfall

By the tipping bucket rain gauge, solar power supply devices and telemetry communication terminals together constitute the telemetry rainfall station. When the integration of rod-type rainfall station when the installation method shown in Figure 5. The rain gauge is connected through the transition support plate and the support column, the solar power supply device, the telemetry communication terminal are installed on the support plate.

When the remote station for the ground installation, only the rain gauge and solar power supply devices, telemetry terminal installed in the support board, and then installed on the cement can be.

3. Rainfall simulation experiments

The instrument has been carried out before the factory artificial precipitation simulation precipitation test and has been based on factory inspection records produced in Figure 6 shows the rain intensity and accuracy of the curve for the user reference. Users in the completion of indoor installation generally do not have to manually simulate the precipitation test, you can directly use the outdoor installation.

If the instrument is in the process of running the instrument to find the accuracy of measurement accuracy should be carried out again artificial simulated precipitation test, re-adjust the instrument, the method is as follows:

a test tool: a dedicated rain cylinder 1, a small dropper;

b before the test:

Before the test, remove the stainless steel outer cylinder to check whether the level of the bubble is centered, whether the tipping is flipped flexible, no jamming phenomenon, and check whether the waterway is smooth, and then use water to fill the mouth,

c water injection test

With two-speed drip method to test the accuracy of the instrument, the method is:

With a dedicated rainfall measuring tube to take 10mm of water, through the diversion funnel slowly into the tipping bucket, to be tipping over the tumbling, that is to stop the water, and then use the dropper to absorb a number of water within the tube, drop by drop into the bucket until the tipping, Then repeat the test, record the number of tumbling reversal and consumption of water; if the tipping over 20 times, the consumption of water 9.7 ~ 9.85mm, you can determine the

instrument dumping point of the normal point, do not have to be adjusted; when the pouring > 9.85mm, The inclination angle is too small, the curve is shifted to the right, the height of the adjustment screw should be appropriately reduced. Generally speaking, the adjustment screw A circle, that is able to change the accuracy of about 3 to 4%.

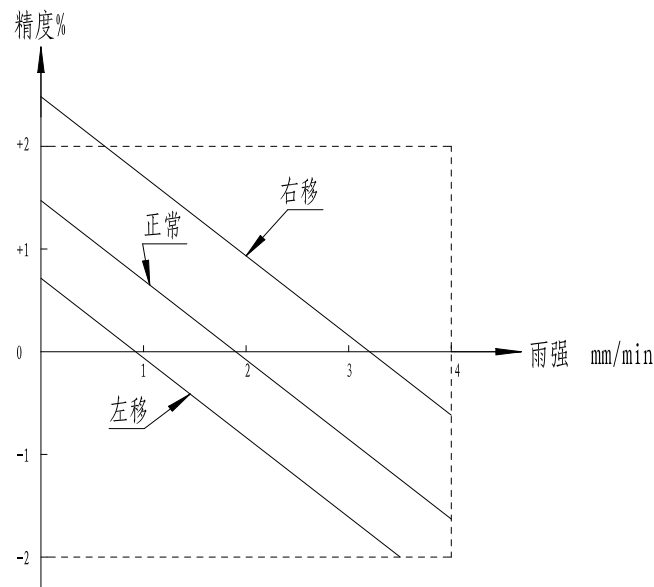

Figure 6

4. Maintenance and maintenance

a daily maintenance

The instrument is long in the outdoors, the use of the environment is very bad, so the instrument bearing the mouth of the mouth should always be wiped with a soft cloth to keep the bearing mouth clean, if found in the mouth of the mouth and other foreign matter should be cleaned, keep the water flow. When the instrument is not used for a long period of time, it should be covered with a cover on the mouth of the instrument.

Long-term work of the instrument generally one month to clean up once, three months must be cleaned once;

b tipping the bucket

Dump is the key component of the instrument, it directly affects the accuracy of the instrument measurement, over time, the tipping bucket wall will be a little dust or oil, therefore, should be tipping bucket cleaning. When cleaning, you can use the water will turn the bucket

inside the wall repeatedly rinse or with a skim brush gently scrub, is strictly prohibited by hand or other objects scrub the inner wall of the bucket.

c Tilt flip flexibility check

Check the hand can be gently up to hold the tipping to keep it in the horizontal position, check the tipping bucket can be about flexible flip. If you find the dump in the horizontal position can not be free to turn, indicating the fork shaft and precious stones between the bearing may be dirt, this time in accordance with the instructions 4.2.2 disassembly tipping method steps to re-remove the tipping bucket to clean the shaft and Gemstone bearings in the foreign body after the installation problem can be resolved.

Note: It is strictly forbidden to add grease or other solution to the gemstone bearing when cleaning the bucket.

5. Frequently Asked Questions and Solutions

Table 1 lists the general failure phenomenon, causes and troubleshooting methods that may occur in the instrument.

Center station form	Rain sensor failure	Solution
Rainfall can not receive the number, but the regular self-reported number can still be received	<p style="text-align: center;">Description Rain sensor No signal output or transmission line failure</p> <ol style="list-style-type: none"> 1, Reed switch failure 2, The magnet is too far from the reed switch 3, Wire break or signal break 4, Dump up 5, The instrument is clogged 	<p style="text-align: center;">Check the next station</p> <ol style="list-style-type: none"> 1, replace 2, Adjustment 3, repair 4, exclude 5, Clear
Rainfall received rainfall compared with the measured rainfall gauge	<ol style="list-style-type: none"> 1, Rain sensor tumbling reversal base point offset, but this error is generally not more than $\pm 10\%$ 2, Magnet and reed pipe position is poor, resulting in good times and bad, so that part of the signal missing 	<ol style="list-style-type: none"> 1, Re-titration to adjust the base point 2, Adjust the distance 3, The objective situation is such that the instrument is fault free

	3, Than the rain gauge and the system rainfall sensor is far apart or strong wind	
The central station to continue to rain, and the actual situation did not rain	Check the outlet is flooding, this phenomenon is often prone to heavy rain	Treatment of water, re-sealing

Note: In the above table, the listed fault phenomena are not all the rain gauge itself failure, check the instrument itself failure and troubleshooting should also check the instrument transmission outlet, data acquisition device, telemetry terminal, room center station and other equipment Whether there is a fault, and one by one to be resolved.

5. Equipment packing list

Tipping bucket gauge	1
Bearing the mouth	1
Tipping	1
Base fixing feet	3
M5 × 25 screws	3
M8 × 120 feet bolts	3
Certificate	1