



Chipsmall Limited consists of a professional team with an average of over 10 year of expertise in the distribution of electronic components. Based in Hongkong, we have already established firm and mutual-benefit business relationships with customers from,Europe,America and south Asia,supplying obsolete and hard-to-find components to meet their specific needs.

With the principle of “Quality Parts,Customers Priority,Honest Operation,and Considerate Service”,our business mainly focus on the distribution of electronic components. Line cards we deal with include Microchip,ALPS,ROHM,Xilinx,Pulse,ON,Everlight and Freescale. Main products comprise IC,Modules,Potentiometer,IC Socket,Relay,Connector.Our parts cover such applications as commercial,industrial, and automotives areas.

We are looking forward to setting up business relationship with you and hope to provide you with the best service and solution. Let us make a better world for our industry!



Contact us

Tel: +86-755-8981 8866 Fax: +86-755-8427 6832

Email & Skype: info@chipsmall.com Web: www.chipsmall.com

Address: A1208, Overseas Decoration Building, #122 Zhenhua RD., Futian, Shenzhen, China



ESP-12E
Brief Spec

规格修改记录 (SPECIFICATION CHANGE HISTORY)

编号	修订日期	修订内容	修订者
1	2012-5-5	最初版本	Harri

Approve 批准	Check 审核	Preparation 拟制	Date 日期

目录

Product Description	4
Description	4
Features	4
Applications	4
Electrical performance	5
Digital IO Pads.....	5
Receiver Sensitivity.....	5
Current Consumption	6
Pin	6
BOOT Mode	7
Reference Schematic	7
Reflow Profile	8
Mechanical Dimensions.....	9
In Kind.....	9
Physical Dimensions	10

Product Description

Description

ESP-12E is a low power consumption of the UART-WiFi module, with very competitive prices in the industry and ultra low power consumption technology, designed specifically for mobile devices and IOT applications, user's physical device can be connected to a Wi-Fi wireless network, Internet or intranet communication and networking capabilities. ESP-07 the use of small ceramic antenna package can support IPEX interface. users have a variety of installation options.

Features

- ▪ 802.11 b/g/n protocol
- ▪ Wi-Fi Direct (P2P), soft-AP
- ▪ Integrated TCP/IP protocol stack
- ▪ +19.5dBm output power in 802.11b mode
- ▪ Power down leakage current of < 10uA
- ▪ Integrated low power 32-bit MCU
- ▪ SDIO 2.0, SPI, UART
- ▪ STBC, 1x1 MIMO, 2x1 MIMO
- ▪ A-MPDU & A-MSDU aggregation & 0.4μs guard interval
- ▪ Wake up and transmit packets in < 2ms
- ▪ Standby power consumption of < 1.0mW (DTIM3)

Applications

- Smart power plugs
- Home automation
- Mesh network
- Industrial wireless control
- Baby monitors
- IP Cameras
- Sensor networks
- Wi-Fi location-aware devices
- Security ID tags
- Wi-Fi position system beacons

Electrical performance

Digital IO Pads

Parameter	Symbol	Min	Max	Unit
InputLow voltage	Vil	-0.3	0.25xVio	V
InputHighVoltage	Vih	0.75xVio	3.3	V
InputLeakageCurrent	Iil		50	nA
OutputLowVoltage	Vol		0.1 xVio	V
OutputHighVoltage	Voh	0.8xVio		V
InputPinCapacitance	Cpad		5	pF
VDDIO	Vio	1.8	3.3	V
MaximumDriveCapability	I _{max}		12	mA
Temperature	T _{amb}	-40	125	°C

Receiver Sensitivity

Description	MIN	Typical	MAX	Unit
Input frequency	2412		2484	MHz
Input impedance		50		Ω
Input reflection			-10	dB
Output power of PA for 72.2Mbps	14	15	16	dBm
Output power of PA for 11b mode	17.5	18.5	19.5	dBm
Sensitivity				
CCK 1Mbps		-98		dBm
CCK 11Mbps		-91		dBm
6Mbps(1/2BPSK)		-93		dBm
54Mbps(3/4 64-QAM)		-75		dBm
HT20 · MCS7 (65Mbps · 72.2Mbps)		-71		dBm
Adjacent Channel Rejection				
OFDM · 6Mbps		37		dB
OFDM · 54Mbps		21		dB
HT20 · MCS0		37		dB
HT20 · MCS7		20		dB

PIN	Function	Description
1	RST	1) Reset Pin. Active low ; 2) NC Or External MCU control ;
2	ADC/TOUT	1) 10-bit ADC Analog Input 0-1V ;
3	EN	1) Module Enable. Active HIGH
4	GPIO16	1) GPIO (WEAK UP)
5	GPIO14	1) GPIO
6	GPIO12	1) GPIO
7	GPIO13	1) GPIO 2) UART2 RXD
8	VDD	1) Power supply . 3.3V IN ;
9	CS0	1) Chip selection of SPI interface.
10	MISO	1) MISO of SPI interface.
11	GPIO9	1) GPIO (Only available on ESP-12-D)
12	GPIO10-	1) GPIO (Only available on ESP-12-D)
13	MOSI	1) MOSI of SPI interface.
14	SCLK	1) Clock of SPI interface.
15	CND	1) Power Ground
16	GPIO15	1) GPIO 2) UART2 TXD
17	GPIO2	1) GPIO 2) WIFI status. Connection inside the module LED
18	GPIO0	1) GPIO
19	GPIO4	1) GPIO
20	GPIO5	1) GPIO
21	RXD0	1) UART0 RXD
22	TXD0	1) UART0 TXD

BOOT Mode

GPIO15	GPIO0	GPIO2	
1	X	X	SDIO/SPI WIFI
0	0	1	UART Download
0	1	1	Flash BOOT

Reference Schematic

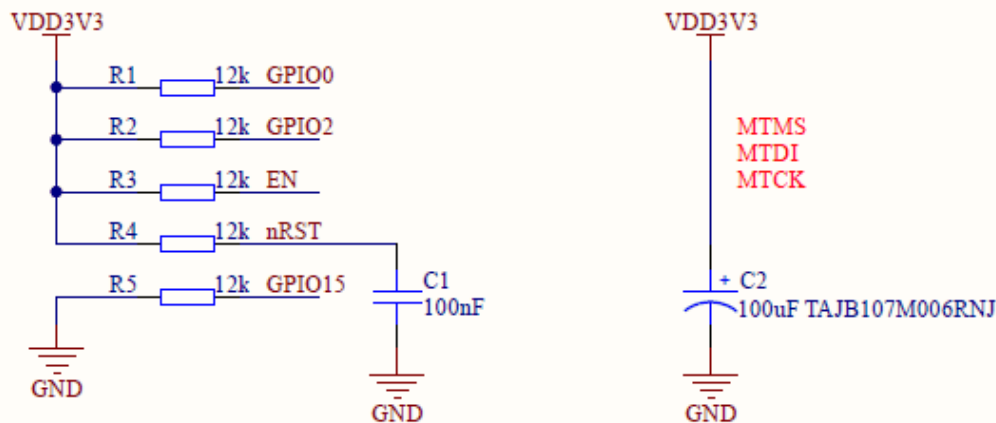

MATTERS NEEDING ATTENTION

On every boot/reset/wakeup,
 GPIO15 MUST keep LOW, GPIO2 MUST keep HIGH.
 GPIO0 HIGH -> RUN MODE, LOW -> FLASH MODE.
 When you need to use the sleep mode, GPIO16 and RST should be connected,
 and GPIO16 will output LOW to reset the system at the time of wakeup.

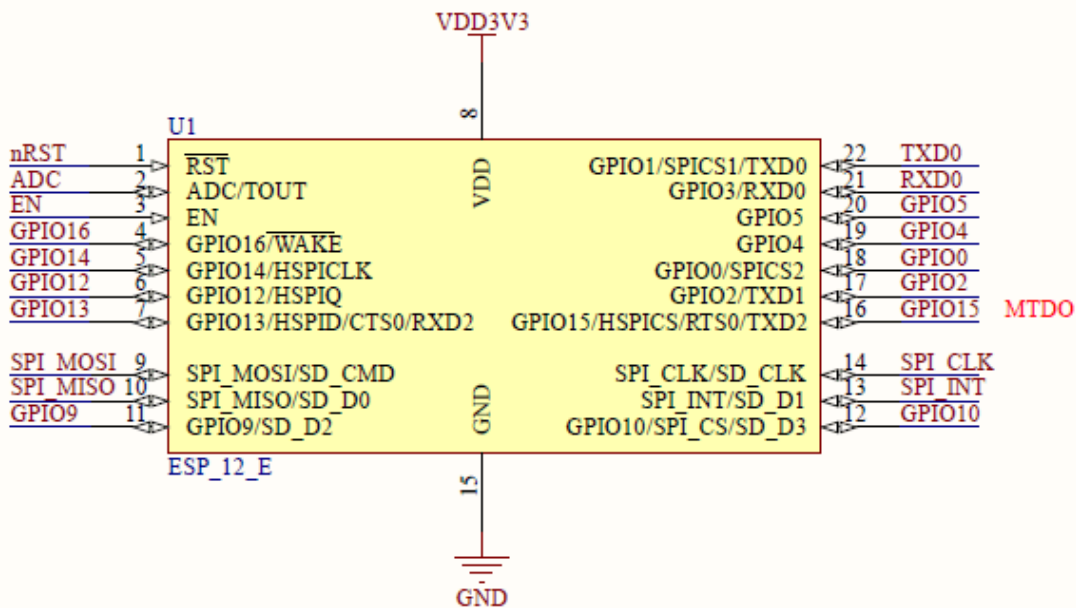

Reflow Profile

Refer to IPC/JEDEC standard; Peak Temperature : <250°C; Number of Times: 2 times;

