



Chipsmall Limited consists of a professional team with an average of over 10 year of expertise in the distribution of electronic components. Based in Hongkong, we have already established firm and mutual-benefit business relationships with customers from,Europe,America and south Asia,supplying obsolete and hard-to-find components to meet their specific needs.

With the principle of “Quality Parts,Customers Priority,Honest Operation,and Considerate Service”,our business mainly focus on the distribution of electronic components. Line cards we deal with include Microchip,ALPS,ROHM,Xilinx,Pulse,ON,Everlight and Freescale. Main products comprise IC,Modules,Potentiometer,IC Socket,Relay,Connector.Our parts cover such applications as commercial,industrial, and automotives areas.

We are looking forward to setting up business relationship with you and hope to provide you with the best service and solution. Let us make a better world for our industry!



Contact us

Tel: +86-755-8981 8866 Fax: +86-755-8427 6832

Email & Skype: info@chipsmall.com Web: www.chipsmall.com

Address: A1208, Overseas Decoration Building, #122 Zhenhua RD., Futian, Shenzhen, China



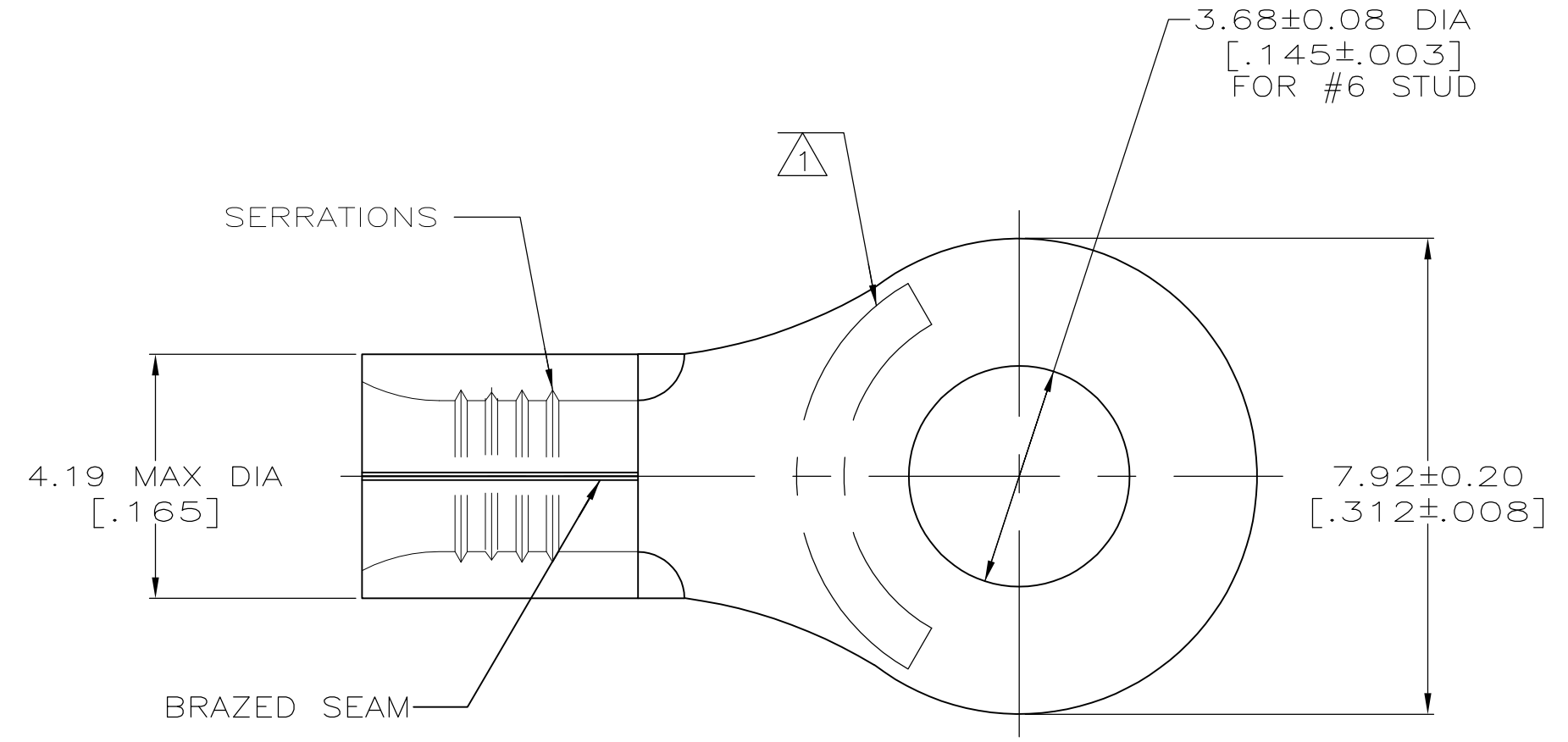

AMP WIRE RANGE	E13288 Listed
16-14 AWG SOLID OR STRANDED	16-14 AWG SOLID OR STRANDED
LR7189 Certified	MILITARY P/N AND CLASS
16-14 AWG SOLID OR STRANDED	M7928/7-7 CLASS 2 P/N 321684 & 2-321684-1 ONLY

STAMP AMP 16-14* APPROX AS SHOWN

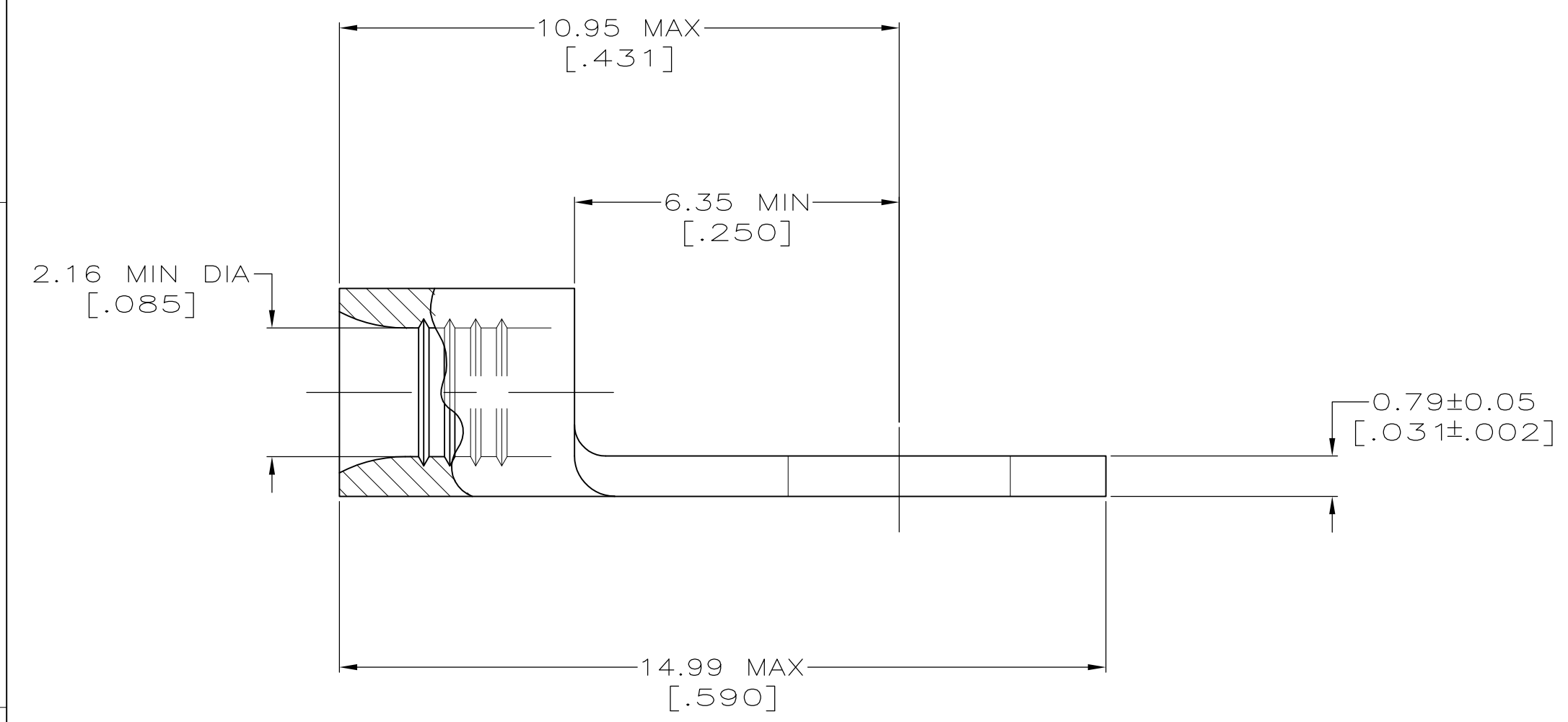

AMP INCORPORATED CUSTOMER SERVICE SYSTEMS		MAX RECOMMENDED OPERATING TEMPERATURE: 170° C MAX
FOR ADDITIONAL PRODUCT INFORMATION OR COPIES OF DRAWINGS AND TECHNICAL DOCUMENTS	PRODUCT INFORMATION CENTER 1-800-522-6752	VOLTAGE RATING: NOT APPLICABLE
FOR APPLICATION TOOLING INFORMATION	TOOLING ASSISTANCE CENTER 1-800-722-1111	WIRE CROSS SECTIONAL AREA RANGE: 1.04-2.62mm ² [2,050-5,180] CIR MILS SOLID OR STRANDED
FOR ORDER ENTRY	1-800-526-5142	THIS DRAWING IS A CONTROLLED DOCUMENT FOR AMP INCORPORATED. IT IS SUBJECT TO CHANGE AND THE CONTROLLING ENGINEERING ORGANIZATION SHOULD BE CONTACTED FOR THE LATEST REVISION.

100	LOOSE PIECE, BOX	8-321684-1
5000	ON TAPE	2-321684-1
---	LOOSE PIECE	321684
QUANTITY	PACKAGING TYPE	PART NO

THIS DRAWING IS A CONTROLLED DOCUMENT.		DWN TA BRINKMAN 3-17-93	TE Connectivity
DIMENSIONS: MM[INCHES]		CHK DA PATTERSON 3-17-93	
TOLERANCES UNLESS OTHERWISE SPECIFIED:		APVD DE MILLER 3-17-93	
0 PLC ± - 1 PLC ± - 2 PLC ± - 3 PLC ± - 4 PLC ± - ANGLES ± ± -		NAME TERMINAL, RING TONGUE, SOLISTRAND™	
MATERIAL COPPER PER ASTM B-152 ANNEALED	FINISH TIN PLATE 0.00254[.000100] MIN THK PER ASTM B-545	WEIGHT -	SIZE A2
CUSTOMER DRAWING		00779	DRAWING NO G-321684
SCALE 10:1		SHEET 1 of 1	RESTRICTED TO -
		REV C1	