



Chipsmall Limited consists of a professional team with an average of over 10 year of expertise in the distribution of electronic components. Based in Hongkong, we have already established firm and mutual-benefit business relationships with customers from,Europe,America and south Asia,supplying obsolete and hard-to-find components to meet their specific needs.

With the principle of “Quality Parts,Customers Priority,Honest Operation,and Considerate Service”,our business mainly focus on the distribution of electronic components. Line cards we deal with include Microchip,ALPS,ROHM,Xilinx,Pulse,ON,Everlight and Freescale. Main products comprise IC,Modules,Potentiometer,IC Socket,Relay,Connector.Our parts cover such applications as commercial,industrial, and automotives areas.

We are looking forward to setting up business relationship with you and hope to provide you with the best service and solution. Let us make a better world for our industry!



Contact us

Tel: +86-755-8981 8866 Fax: +86-755-8427 6832

Email & Skype: info@chipsmall.com Web: www.chipsmall.com

Address: A1208, Overseas Decoration Building, #122 Zhenhua RD., Futian, Shenzhen, China



VICOR CONFIDENTIAL

THIS DOCUMENT AND THE DATA DISCLOSED HEREIN OR HEREWITH IS NOT TO BE REPRODUCED, USED OR DISCLOSED IN WHOLE OR IN PART TO ANYONE WITHOUT THE PERMISSION OF VICOR CORP.

REVISIONS

REV	DESCRIPTION	DATE	APPROVED
1	RELEASED PER E053488 PEI	01/04/06	ECF
2	DOCUMENT REVISED PER E091418 JS	08/19/09	REJH
3	REDRAWN PER E100902 DCS	7/14/10	KUK

#4-40 UNC-2B COLD FORM TAP
.120 DP MIN. FROM FAR SIDE
DO NOT BREAK THRU
(6) PL.

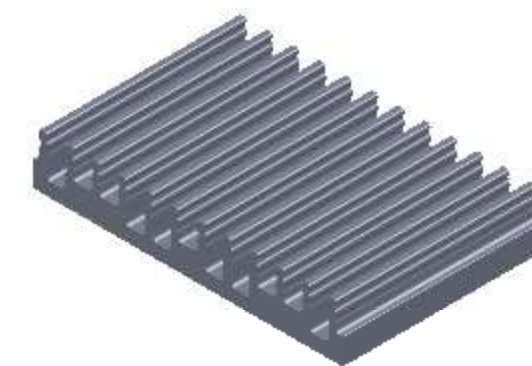
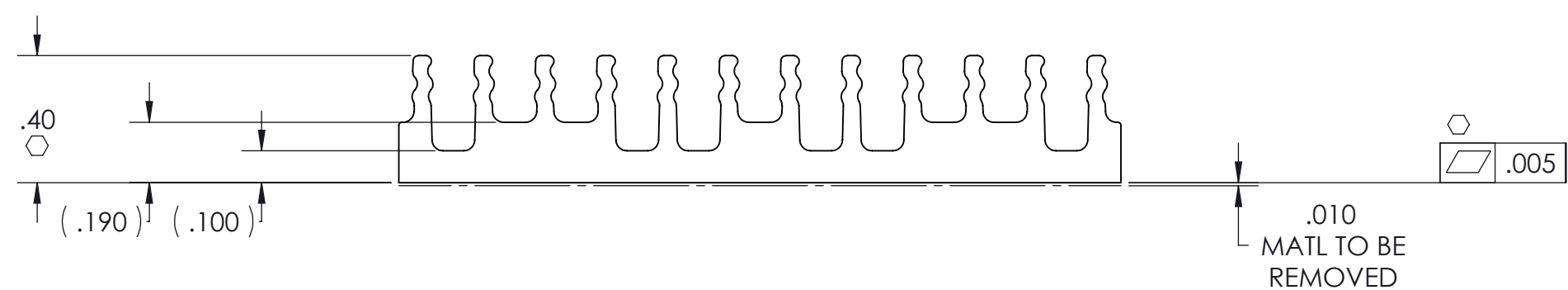
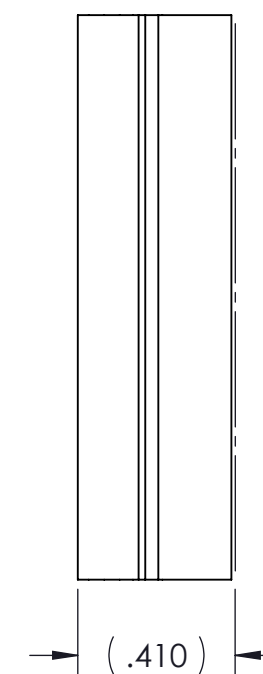
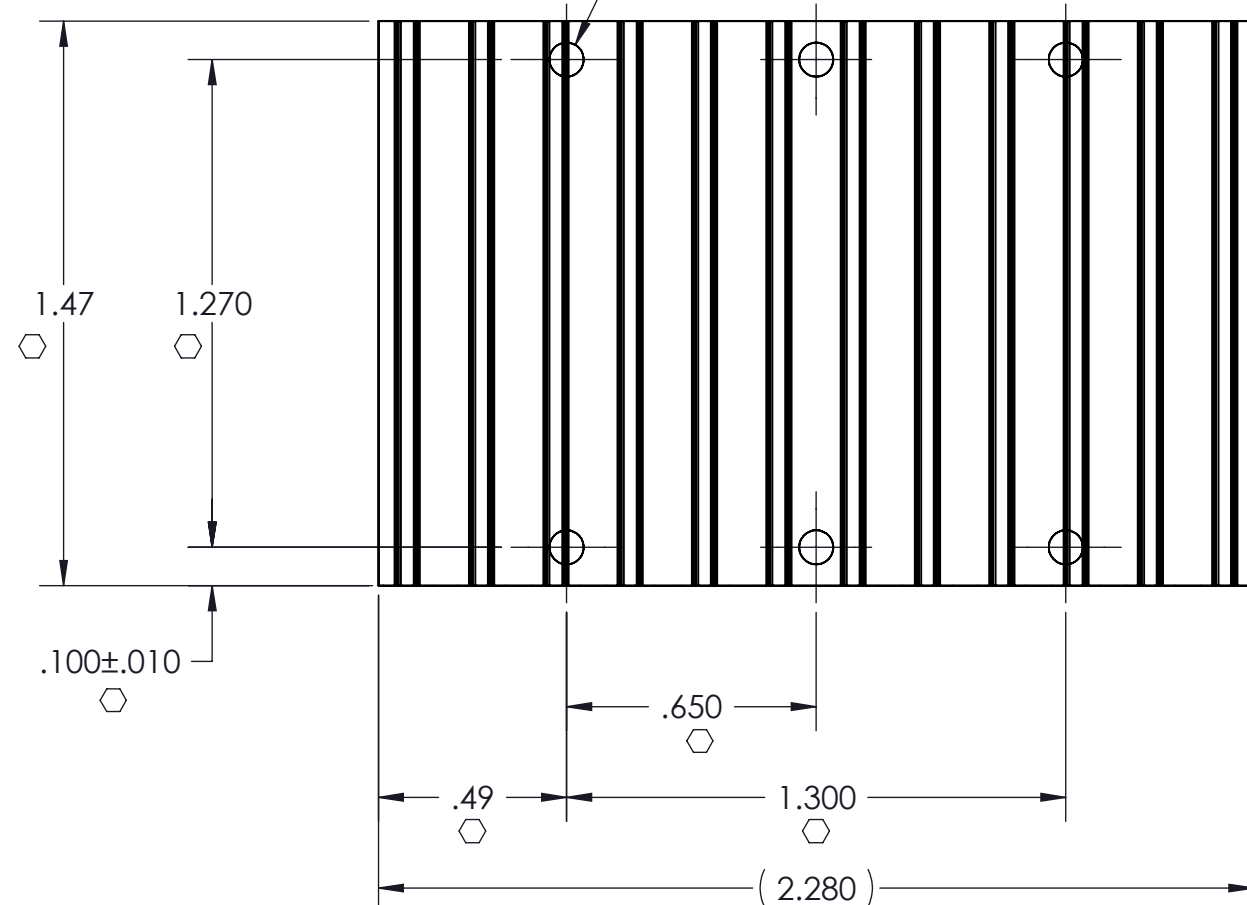

NOTES:

1. MATERIAL: EXTRUSION SEE SHEET 2 OF 2.
2. REMOVE ALL BURRS AND SHARP EDGES.
3. CLEAR FINISH, RoHS COMPLIANT, CHROMIUM FREE PER CST-0001 LATEST REVISION.
4. "○" DENOTES CRITICAL CHARACTERISTIC FOR LOT INSPECTION.
5. DIMENSIONS ARE INCHES ONLY.

DRAWN	DATE	VICOR			
P.E. IENI	12/01/05				
MATERIAL	UNLESS OTHERWISE SPECIFIED DIMENSIONS ARE INCH [MM] TOLERANCES ARE: DECIMALS ANGLES X.XX [X.X] = ±0.01 [0.25] ±1° X.XXX [X.XX] = ±0.005 [0.127]	HS CFG "C" X-FLOW, .4H LOW FLOW, THREADED			
SEE NOTES					
FINISH	THIRD ANGLE PROJECTION	SIZE	CAGE CODE	DWG NO	REV
SEE NOTES		C	67131	32173	3
		SCALE 2 : 1		SHEET 1 OF 2	

THIS DOCUMENT AND THE DATA DISCLOSED HEREIN OR HEREWITH IS NOT TO BE REPRODUCED, USED OR DISCLOSED IN WHOLE OR IN PART TO ANYONE WITHOUT THE PERMISSION OF VICOR CORP.

REV	DESCRIPTION	DATE	APPROVED
	SEE SHEET 1 OF 2		

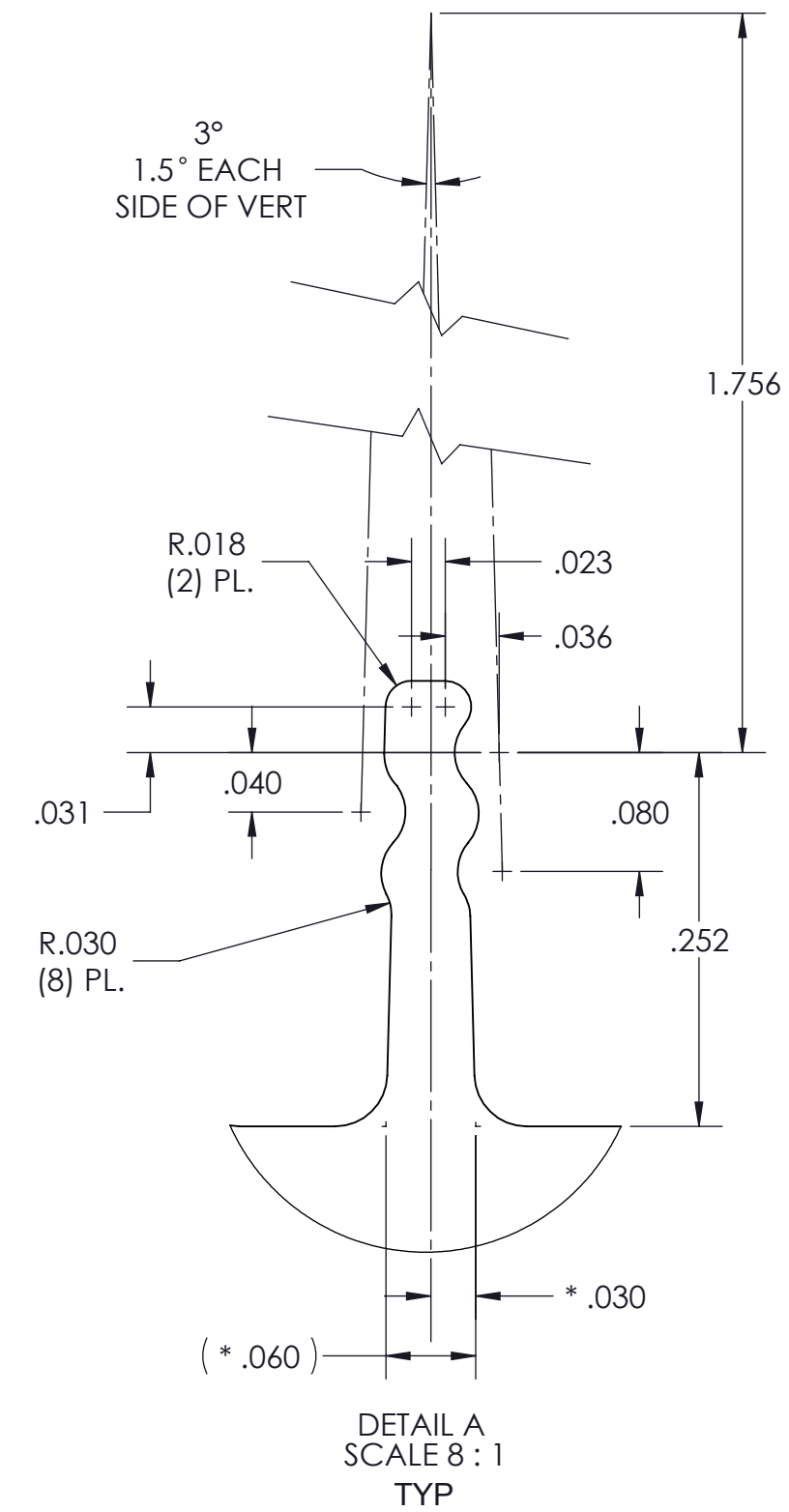
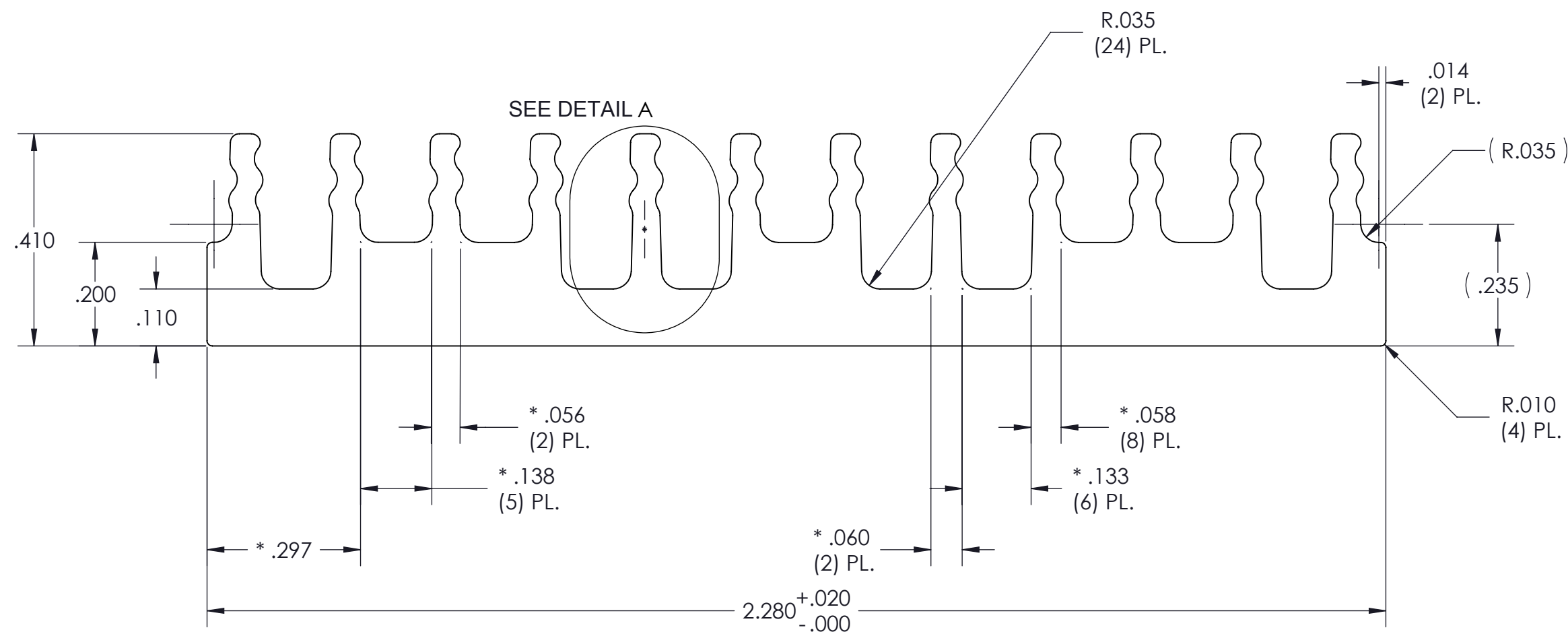

PROFILE COMMON FOR
30722
32173
30721
30184

NOTES:

1. MATL: ALUMINUM 6063-T5
2. *DENOTES DIMENSIONS TO THEORETICAL SHARP CORNER
3. ALL DIMENSIONS ARE CRITICAL CHARACTERISTICS.
4. RoHS COMPLIANT PER CST-0001 LATEST REVISION.
5. WORKMANSHIP STANDARDS WS-0004, WS-0006 AND WS-0007 APPLY TO THIS PART.
6. DIMENSIONS ARE INCHES ONLY.

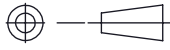
DRAWN JSARIPPELLA		DATE 08/19/09		VICOR SWD		
MATERIAL SEE NOTES		UNLESS OTHERWISE SPECIFIED DIMENSIONS ARE INCH [MM] TOLERANCES ARE: DECIMALS ANGLES X.XX [X.X] = ±0.01 [0.25] ±1° X.XXX [X.XX] = ±0.005 [0.127]		HS CFG "C" X-FLOW, .4H LOW FLOW, THREADED, EXTRUSION		
FINISH SEE NOTES		THIRD ANGLE PROJECTION 		SIZE C	CAGE CODE 67131	DWG NO 32173
				REV 3	SCALE 4 : 1 SHEET 2 OF 2	