



Chipsmall Limited consists of a professional team with an average of over 10 year of expertise in the distribution of electronic components. Based in Hongkong, we have already established firm and mutual-benefit business relationships with customers from,Europe,America and south Asia,supplying obsolete and hard-to-find components to meet their specific needs.

With the principle of “Quality Parts,Customers Priority,Honest Operation,and Considerate Service”,our business mainly focus on the distribution of electronic components. Line cards we deal with include Microchip,ALPS,ROHM,Xilinx,Pulse,ON,Everlight and Freescale. Main products comprise IC,Modules,Potentiometer,IC Socket,Relay,Connector.Our parts cover such applications as commercial,industrial, and automotives areas.

We are looking forward to setting up business relationship with you and hope to provide you with the best service and solution. Let us make a better world for our industry!



Contact us

Tel: +86-755-8981 8866 Fax: +86-755-8427 6832

Email & Skype: info@chipsmall.com Web: www.chipsmall.com

Address: A1208, Overseas Decoration Building, #122 Zhenhua RD., Futian, Shenzhen, China



THIS DRAWING IS UNPUBLISHED. RELEASED FOR PUBLICATION
 © COPYRIGHT - By - ALL RIGHTS RESERVED.

LOC	DIST	REVISIONS					
		P	LTR	DESCRIPTION	DATE	DWN	APVD
G	14		F2	REVISED PER ECO-12-003796	28FEB12	KH	DR

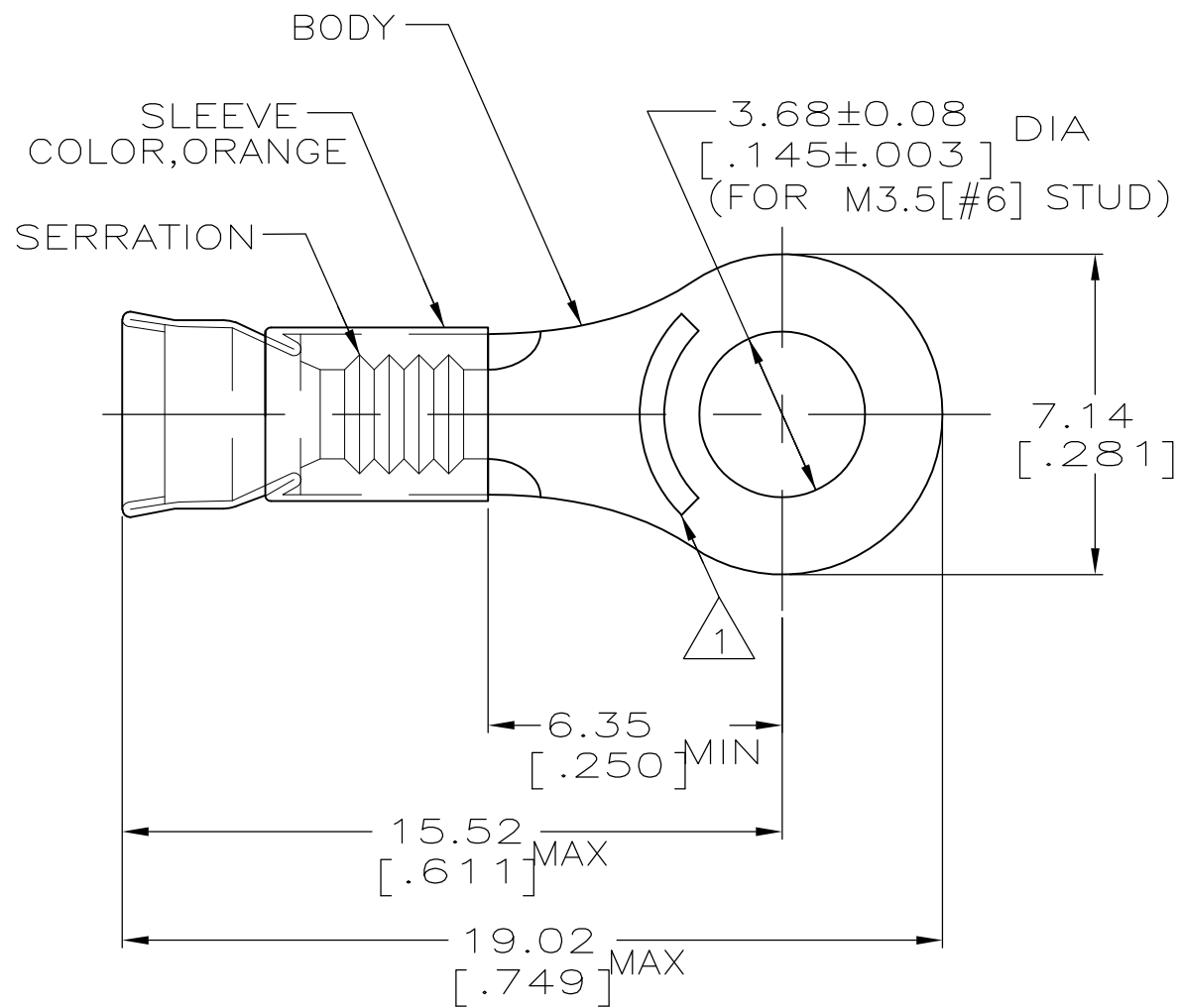

- 1 22-18 STAMP AMP APPROX AS SHOWN
22-16 TERMINALS ARE STAMPED 22-18 IN ACCORDANCE WITH MILITARY SPEC SAE AS7928
COMMERCIAL WIRE RANGE IS 22-16
- 2 WIRE INSUL DIA, 2.67-3.56[.105-.140]
- 3 TONGUE MATL THK, 0.79±0.05[.031±.002]
- 4 BODY: GOLD PLATE 0.00127[.000050]MIN EXT. THK PER ASTM B488, TYPE 1, CODE C OVER NICKEL FLASH PER SAE AMS QQ-N-290 OVER WOODS NICKEL FLASH PER ASTM B558.
- 5 NOTE DELETED.

260°C [500°F]	4	1000	LOOSE PIECE	321892-1
649°C [1200°F]	-	1000	LOOSE PIECE	321892
MAX OPERATING TEMP	FINISH	QTY	PACKAGE TYPE	PART NO

AMP INCORPORATED CUSTOMER SERVICE SYSTEM		MAX RECOMMENDED OPERATING TEMPERATURE: SEE TABLE	THIS DRAWING IS A CONTROLLED DOCUMENT.		DWN L OLMEDA 10OCT94	TE Connectivity				
FOR ADDITIONAL PRODUCT INFORMATION OR COPIES OF DRAWINGS AND TECHNICAL DOCUMENTS	PRODUCT INFORMATION CENTER 1-800-522-6752	VOLTAGE RATING: -	DIMENSIONS: mm [INCHES]	TOLERANCES UNLESS OTHERWISE SPECIFIED:	CHK M ELLIS 10OCT94					NAME
FOR APPLICATION TOOLING INFORMATION	TOOLING ASSISTANCE CENTER 1-800-722-1111	CIRCULAR MIL AREA: 0.26mm ² -1.65mm ² [509-3260] STRANDED WIRE			APVD S BORTNER 10OCT94	TERMINAL, RING TONGUE, STRATOTHERM, DIAMOND GRIP, WIRE SIZE: 22-16AWG				
FOR ORDER ENTRY	1-800-526-5142	MATERIAL BODY, NI PER ASTM B162 SLEEVE, NI SIL PER ASTM B122	SEE TABLE		PRODUCT SPEC -	SIZE A3	CAGE CODE 00779	DRAWING NO C-321892	RESTRICTED TO -	
					WEIGHT -	CUSTOMER DRAWING		SCALE 6:1	SHEET 1 OF 1	REV F2