



Chipsmall Limited consists of a professional team with an average of over 10 year of expertise in the distribution of electronic components. Based in Hongkong, we have already established firm and mutual-benefit business relationships with customers from,Europe,America and south Asia,supplying obsolete and hard-to-find components to meet their specific needs.

With the principle of “Quality Parts,Customers Priority,Honest Operation,and Considerate Service”,our business mainly focus on the distribution of electronic components. Line cards we deal with include Microchip,ALPS,ROHM,Xilinx,Pulse,ON,Everlight and Freescale. Main products comprise IC,Modules,Potentiometer,IC Socket,Relay,Connector.Our parts cover such applications as commercial,industrial, and automotives areas.

We are looking forward to setting up business relationship with you and hope to provide you with the best service and solution. Let us make a better world for our industry!



## Contact us

Tel: +86-755-8981 8866 Fax: +86-755-8427 6832

Email & Skype: info@chipsmall.com Web: www.chipsmall.com

Address: A1208, Overseas Decoration Building, #122 Zhenhua RD., Futian, Shenzhen, China



4

3

2

1

THIS DRAWING IS UNPUBLISHED. RELEASED FOR PUBLICATION, 19 .

© COPYRIGHT 19 BY AMP INCORPORATED. ALL RIGHTS RESERVED.

LOC	DIST	REVISIONS					
		P	LTR	DESCRIPTION	DATE	DWN	APVD
G	14			ADDED -2 PER 0G3A-0273-00	22MAY00	JR	MS

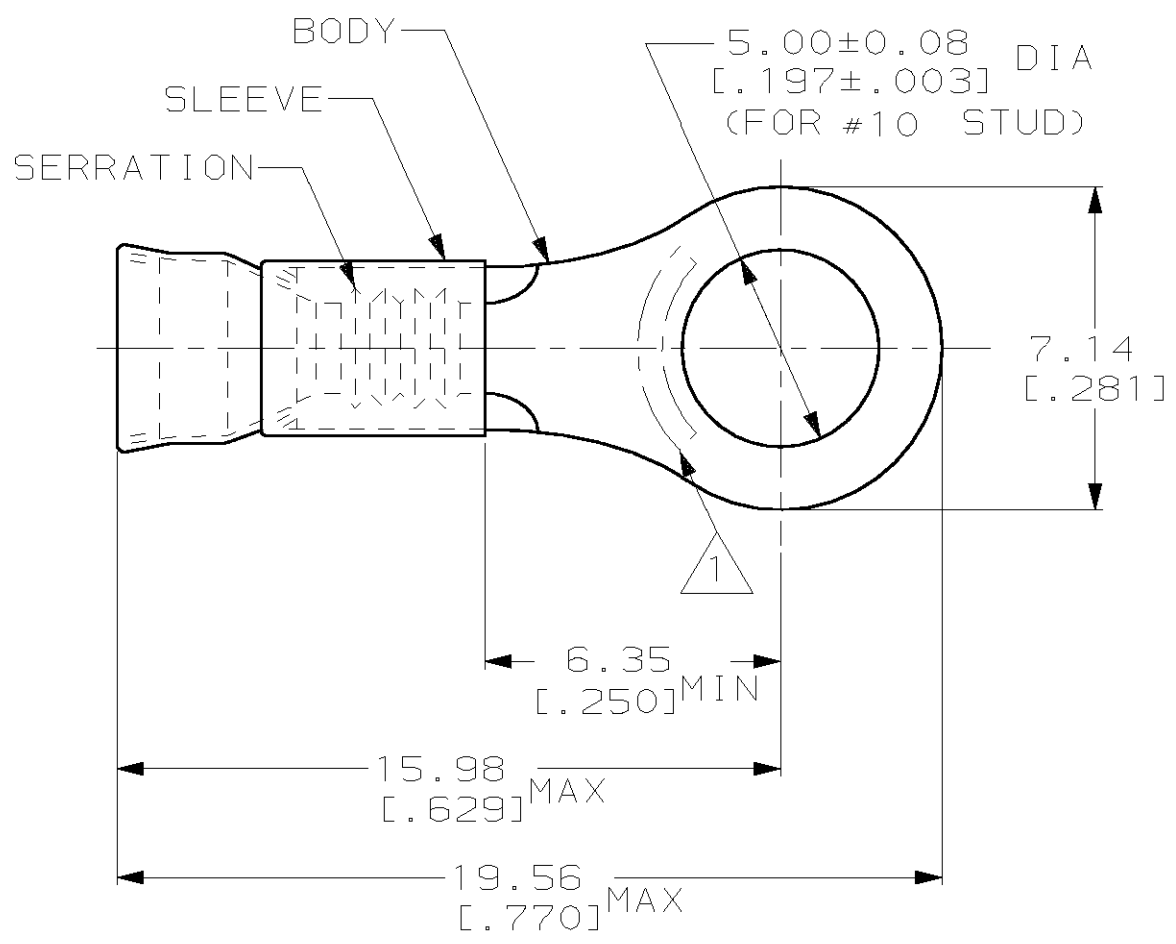

- ① STAMP AMP 22-18\*APPROX AS SHOWN  
22-16 TERMINALS ARE STAMPED 22-18 IN ACCORDANCE WITH MILITARY SPEC MIL-T-7928 COMMERCIAL WIRE RANGE IS 22-16
- 2. WIRE INSUL DIA, 1.30-2.79 [.051-.110]
- 3. TONGUE MATL THK, 0.79±0.05 [.031±.002]
- ④ NICKEL PL PER QQ-N-290
- ⑤ GOLD PL PER MIL-G-45204 OVER NICKEL PL PER QQ-N-290
- ⑥ PRELIMINARY - NOT FOR PRODUCTION

QTY	PACKAGE TYPE	PART NO
5000	ON TAPE, REEL	④ 323153-2
1000	LOOSE PIECE	④ 323153-1
1000	LOOSE PIECE	④ 323153

AMP INCORPORATED CUSTOMER SERVICE SYSTEM		MAX RECOMMENDED OPERATING TEMPERATURE: 343°C [650°F]	THIS DRAWING IS A CONTROLLED DOCUMENT FOR AMP INCORPORATED. IT IS SUBJECT TO CHANGE AND THE CONTROLLING ENGINEERING ORGANIZATION SHOULD BE CONTACTED FOR THE LATEST REVISION.		DWN L OLMEDA 100CT94	AMP Incorporated Harrisburg, PA 17105-3608
FOR ADDITIONAL PRODUCT INFORMATION OR COPIES OF DRAWINGS AND TECHNICAL DOCUMENTS	PRODUCT INFORMATION CENTER 1-800-522-6752		VOLTAGE RATING: -	DIMENSIONS: mm [in]	TOLERANCES UNLESS OTHERWISE SPECIFIED: 0 PLC ±- 1 PLC ±- 2 PLC ±0.20 [.008] 3 PLC ±- 4 PLC ±- ANGLES ±-	
FOR APPLICATION TOOLING INFORMATION	TOOLING ASSISTANCE CENTER 1-800-722-1111	CIRCULAR MIL AREA: 0.26mm <sup>2</sup> -1.65mm <sup>2</sup> [509-3260]	MATERIAL BODY, CU PER ASTM B152 SLEEVE, NI SIL PER ASTM B122	FINISH SEE TABLE	APVD S BORTNER 100CT94	NAME TERMINAL, RING TONGUE, STRATOTHERM, DIAMOND GRIP, WIRE SIZE, 22-16 AWG
FOR ORDER ENTRY	1-800-526-5142	STRANDED WIRE			PRODUCT SPEC -	SIZE A3
					APPLICATION SPEC -	CAGE CODE 00779
					WEIGHT -	DRAWING NO C-323153
					CUSTOMER DRAWING	SCALE 6:1
						SHEET 1 OF 1
						REV G