



Chipsmall Limited consists of a professional team with an average of over 10 year of expertise in the distribution of electronic components. Based in Hongkong, we have already established firm and mutual-benefit business relationships with customers from,Europe,America and south Asia,supplying obsolete and hard-to-find components to meet their specific needs.

With the principle of "Quality Parts,Customers Priority,Honest Operation,and Considerate Service",our business mainly focus on the distribution of electronic components. Line cards we deal with include Microchip,ALPS,ROHM,Xilinx,Pulse,ON,Everlight and Freescale. Main products comprise IC,Modules,Potentiometer,IC Socket,Relay,Connector.Our parts cover such applications as commercial,industrial, and automotives areas.

We are looking forward to setting up business relationship with you and hope to provide you with the best service and solution. Let us make a better world for our industry!



Contact us

Tel: +86-755-8981 8866 Fax: +86-755-8427 6832

Email & Skype: info@chipsmall.com Web: www.chipsmall.com

Address: A1208, Overseas Decoration Building, #122 Zhenhua RD., Futian, Shenzhen, China



Model 3269 Adapter – BNC Female To Miniature Double Banana Plug

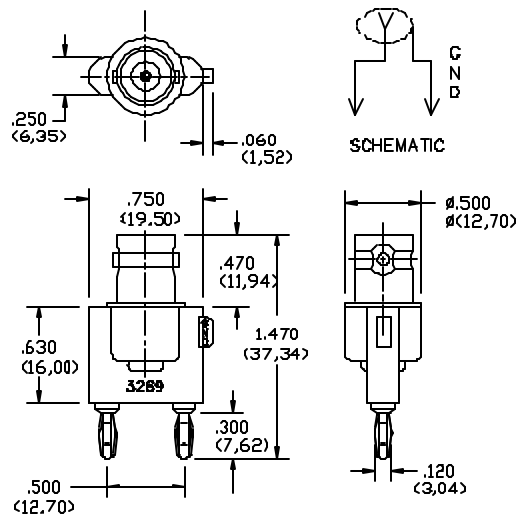

FEATURES:

- Allows a BNC male to be used with equipment having .5" (12,7) spaced miniature .104" (2,4) dia. banana jacks
- Excellent for adapting test equipment to BNC coaxial cables

MATERIALS:

Upper Conn: BNC Female.

Finish: Tarnish Resistant

Center Contact: Gold plated

Insulation: ABS molded to BNC male and Banana Plug

Color: Black

Marking: "POMONA ELECTRONICS CALIF. 3269"

Lower Conn: Miniature Double Banana Plug

Material: Spring, Beryllium Copper

Plug Body: Brass

Finish: Gold plated

RATINGS:

Operating Temperature: +50° C. (+122° F.) Max.

Operating Voltage: Hand-Held Testing: 30VAC/60VDC Max.

Hands Free Testing in controlled voltage environments: 500 VRMS Max.

ORDERING INFORMATION: Model 3269

All dimensions are in inches. Tolerances (except noted): .xx = ±.02" (.51 mm), .xxx = ±.005" (.127 mm).

All specifications are to the latest revisions. Specifications are subject to change without notice.

Registered trademarks are the property of their respective companies. Made in USA

Sales: 800-490-2361 Fax: 888-403-3360
Technical Assistance: 800-241-2060

PomonaACCESS 90572 (800) 444-6785 or (425) 446-6010
More drawings available at www.pomonaelectronics.com